



## **CM540 Series High Torque Vector Inverter**

### User Manual

Version: V 9.21

Date of Filing:2019-04-24



## Foreword

Catalogue.....	1
Brief Introduction.....	2
Chapter 1 Safety Information and Warning.....	4
1.1 Safety Information and Warning.....	4
1.2 Notes.....	8
Chapter 2 Product Information.....	13
2.1 Naming Rule.....	13
2.2 Nameplate.....	13
2.3 Electric Date.....	14
2.4 Technology Specifications.....	15
2.5 Product Outline and Installation Hole Sizes.....	19
2.5.1 The Outline Drawing of the Inverter.....	19
2.5.2 The Dimension and Installation Hole Size of Inverter.....	20
Table 2-3 The Dimension and Installation Hole Size.....	20
2.5.3 Outline Size of Keyboard.....	21
2.7 Optional Parts of the Inverter.....	23
2.8 The Selection and Size of External DC Reactor.....	24
2.9 Selection of Braking Package.....	25
2.10 Frequency Inverter Daily Maintenance.....	27
Chapter 3 Mechanical and Electrical Installation.....	30
3.1 Mechanical Installation.....	30
3.1.1 Installation Environment.....	30
3.1.2 Installation Attention.....	31
3.2 Electrical Installation.....	31
3.2.1 External Electrical Component Selection.....	31
3.2.2 Wiring.....	33
1、0.4KW-400KW basic operation wiring.....	33
3.2.3 Main Circuit Terminals and Wiring.....	34
3.2.4 Control Circuit and Wiring.....	36
Chapter 4 Keyboard Operation and Display.....	41
4.1 Introduction of Keyboard Operation and Display Interface.....	41
4.2 Display Mode and Switching Operation of Parameter Group.....	43
4.3 Viewing and Modifying Function Codes.....	44
4.4 The Operation Mode of User Customized Parameter.....	44
4.5 User Modified Function Code.....	45
4.6 Definition and Operation of the Multifunction Key (MF.K).....	45
4.7 Viewing Status Parameters.....	45

4.8 Starting or Stopping the AC Drive.....	48
4.8.1 Selecting the Start/Stop Command Source.....	48
4.8.2 Start Mode.....	50
4.8.3 Stop Mode.....	50
4.8.4 Timing Stop.....	50
4.8.5 JOG Running.....	51
4.9 Setting the Running Frequency.....	51
4.9.1 Frequency Setting by the Main Frequency Source... 51	
4.9.2 Frequency Setting by the Auxiliary Frequency Source	52
.....	
4.9.3 Binding Command Source to Frequency Source.....	52
4.9.4 AI as the Frequency Source.....	53
4.9.5 Pulse Setting as the Frequency Source.....	53
4.9.6 Frequency Closed-Loop Control.....	54
4.9.7 Swing Mode.....	54
4.9.8 Multi-Speed Mode.....	54
4.9.9 Setting the Motor Rotating Direction.....	55
4.9.10 Setting the Fixed Length Control Mode.....	55
4.9.11 Use of the Counting Function.....	56
4.10 Setting and Auto-tuning of Motor Parameters.....	57
4.10.1 Motor Parameters to Be Set.....	57
4.10.2 Motor Auto-tuning.....	58
4.10.3 Setting and Switchover of Multiple Groups of Motor	
Parameters.....	60
4.11 Use of S Terminals.....	60
4.12 Use of DO Terminals.....	61
4.13 V Use of Input Signal Terminals.....	61
4.14 Use of FM Terminals.....	62
4.15 Use of the PG Terminal.....	63
4.16 Use of Serial Communication.....	63
4.18 Password Setting.....	64
4.19 Parameter Saving and Default Setting Restoring.....	64
Chapter5 Function Code Table.....	65
Chapter6 Description of Function Codes.....	120
Chapter7 EMC (Electromagnetic Compatibility) .....	264
7.1 Definition.....	264
7.2 EMC Standard Introduction.....	264
7.3 EMC Direction.....	264
7.3.1 Harmonic Influence.....	264
7.3.2 EMI and Installation Notes.....	265
7.3.3 Handle Interference of the Environment to Interfere	
the Drive.....	265
7.3.4 Handle Interference Generated by Drive to Interfere	

the Environment.....	265
7.3.5 Leakage Current and Its Processing System.....	266
7.3.6 Note of Installing EMC Input Filter in the Power Input Side.....	267
Chapter 8  Faults and Solutions.....	268
8.1 Faults and Solutions.....	268
8.2 Common Faults and Solutions.....	282
Appendix E: CM540 Modbus Communication Protocol.....	285



## Catalogue

First thank you for purchasing the CM540 series inverter!

The CM540 series is a high torque type vector inverter. Its motor control performance increases obviously. The inverter can implement the control of asynchronous motor and permanent magnet synchronous motor (PMSM), supports multi-kind PG and IO cards(including CAN COMMUNICATION).The function is more powerful. It is used to drive various automation production equipment involving textile, paper-making, machine tool, packing, food, elevator, crane, petroleum machinery, fan, pump etc.

This manual describes the correct use of the CM540 series AC drive, including selection, parameter setting, commissioning, maintenance & inspection. Read and understand the manual before use and forward the manual to the end user.

Notes
<ul style="list-style-type: none"><li>● Remember to install the covers or protective guards as specified first, and then perform operations in accordance with the instructions.</li><li>● The drawings in the manual are shown for description only and may not match the product you purchased.</li><li>● The instructions are subject to change, without notice, due to product upgrade, specification modification as well as efforts to increase the accuracy and convenience of the manual.</li><li>● Contact our agents or customer service center if you have problems during the use.</li></ul>

## Brief Introduction

The CM540 series AC drive incorporates the following improvements:

1. Control of asynchronous motor and PMSM : It supports vector control of three-phase AC asynchronous motor and three-phase AC MSM.
2. Diversified control modes : It supports four control modes, namely, sensor less flux vector control (SFVC), closed-loop vector control (CLVC) and V/F control, V/F separating control.
3. Multiple communication protocols : It supports communication via Modbus-RTU, CAN link.
4. Multiple encoder types : It supports various encoders such as differential encoder, open-collector encoder or push-pull output encoder.
5. All-new SFVC algorithm : It introduces an all-new sensor less flux vector control (SFVC) algorithm that gives better low-speed stability, enhanced low-frequency loading capacity, and supports torque control.
6. External powerful expansion cards, could realize CAN communication function, jecton machine function, motor PT100 thermal protection etc.
7. The special function of CM540 series in below table:

Function	Describe
Virtual I/O	It can implement various simple logic functions.
Motor overheat protection	The optional EXT2-IO extension card enables AI3 to receive the signal from the motor temperature sensor input (PT100) thereby providing motor overheat protection.
Rapid current limit	It helps to avoid frequent occurrence of over current faults of the AC drive.
Multi-motor switchover	Two motors can be switched over via two groups of motor parameters.
Restoring user parameters	It allows you to save or restore the parameters set by yourself.



Higher-accuracy AI/AO	The AI/AO accuracy can reach almost 20 mv via factory correction or on-site correction.
Customized parameter display	You can customize the parameters that need to be displayed.
Modified parameter display	You can view the modified parameters.
PID parameters switchover	Two groups of PID parameters can be switched over via terminals or can be automatically switched over according to deviation.
PID feedback loss detection	The PID feedback loss value can be set to realize PID protection.
DI/DO response delay	You can set DI/DO response delay time.
Power dip ride through	It ensures that the AC drive continues to run for a short time when an instantaneous power failure or sudden voltage reduction occurs.
Timing operation	The AC drive supports timing operation for 6500 minutes at maximum.

### Product Checking

Upon unpacking, check:

- Whether the nameplate model and AC drive ratings are consistent with your order. The box contains the AC drive, certificate of conformity, user manual and warranty card.
- Whether the AC drive is damaged during transportation. If you find any omission or damage, contact company or your supplier immediately.

### First-time Use

For the users who use this product for the first time, read the manual carefully. If in doubt concerning some functions or performances, contact the technical support personnel of company to ensure correct use.

The instructions are subject to change, without notice, due to product upgrade, specification modification as well as efforts to increase the accuracy and convenience of the manual.

## Chapter 1 Safety Information and Warning

In this manual, the notices are divided two type as follows:



**DANGER** indicates that failure to comply with the notice will result in severe personal injury or even death.



**WARNING** indicates that failure to comply with the notice will result in personal injury or property damage.

Read this manual carefully so that you have a thorough understanding.

Installation, commissioning or maintenance may be performed in conjunction with this chapter. company will assume no liability or responsibility for any injury or loss caused by improper operation.

### 1.1 Safety Information and Warning

#### 1.1.1 Before Installation



#### **DANGER**

- Do not install the equipment if you find water seepage, component missing or damage upon unpacking.
- Do not install the equipment if the packing list does not conform to the product you received.



#### **WARNING**

- Handle the equipment with care during transportation to prevent damage to the equipment.
- Do not use the equipment with damaged or missing components. Failure to comply will result in personal injury.
- Do not touch the components with your hands. Failure to comply will result in static electricity damage.

#### 1.1.2 During Installation

**DANGER**

- Install the equipment on incombustible objects such as metal, and keep it away from combustible materials. Failure to comply may result in a fire.
- Do not loosen the fixed screws of the components, especially the screws with red mark.

**WARNING**

- Do not drop wire end or screw into the AC drive. Failure to comply will result in damage to the AC drive.
- Install the AC drive in places free of vibration and direct sunlight.
- Arrange the installation positions properly when two AC drives are laid in the same cabinet to ensure the cooling effect.

### 1.1.3 At Wiring

**DANGER**

- Wiring must be performed only by qualified personnel under instructions described in this manual. Failure to comply may result in unexpected accidents.
- A circuit breaker must be used to isolate the power supply and the AC drive. Failure to comply may result in a fire.
- Ensure that the power supply is cut off before wiring. Failure to comply may result in electric shock.
- Tie the AC drive to ground properly by standard. Failure to comply may result in electric shock

**WARNING**

- Never connect the power cables to the output terminals (U, V, W) of the AC drive.  
Pay attention to the marks of the wiring terminals and ensure correct wiring. Failure to comply will result in damage to the AC drive.
- Never connect the braking resistor between the DC bus terminals (+) and (-).

Failure to comply may result in a fire.

- Use wire sizes recommended in the manual. Failure to comply may result in accidents.
- Use a shielded cable for the encoder, and ensure that the shielding layer is reliably grounded.

### 1.1.4 Before Power-on



#### **DANGER**

- Check that the following requirements are met:

The voltage class of the power supply is consistent with the rated voltage class of the AC drive.

The input terminals (R, S, T) and output terminals (U, V, W) are properly connected.

No short-circuit exists in the peripheral circuit.

The wiring is secured.

Failure to comply will result in damage to the AC drive

- Do not perform the voltage resistance test on any part of the AC drive because such test has been done in the factory. Failure to comply will result in accidents.



#### **WARNING**

- Cover the AC drive properly before power-on to prevent electric shock.
- All peripheral devices must be connected properly under the instructions described in this manual. Failure to comply will result in accidents

### 1.1.5 After Power-on



#### **DANGER**

- Do not open the AC drive's cover after power-on. Failure to comply may result in electric shock.
- Don't touch the drive and peripheral circuit with wet hands.

- Do not touch any I/O terminal of the AC drive. Failure to comply may result in electric shock.
- Initial power on, the drive is checking the safety of its external circuit with strong electric, so please don't touch the drive's terminals U、V、W and the motor's terminals.

### 1.1.6 During Operation



#### **DANGER**

- Do not touch the fan or the discharging resistor to check the temperature. Failure to comply will result in personal burnt.
- Signal detection must be performed only by qualified personnel during operation.  
Failure to comply will result in personal injury or damage to the AC drive.



#### **WARNING**

- Avoid objects falling into the AC drive when it is running. Failure to comply will result in damage to the AC drive.
- Do not start/stop the AC drive by turning the contactor ON/OFF. Failure to comply will result in damage to the AC drive.

### 1.1.7 During Maintenance



#### **DANGER**

- Repair or maintenance of the AC drive may be performed only by qualified personnel.  
Failure to comply will result in personal injury or damage to the AC drive.
- Do not repair or maintain the AC drive at power-on. Failure to comply will result in electric shock.
- Repair or maintain the AC drive only ten minutes after the AC drive is powered off.  
This allows for the residual voltage in the capacitor to discharge to a safe

value.

Failure to comply will result in personal injury.

- Ensure that the AC drive is disconnected from all power supplies before starting repair or maintenance on the AC drive.
- Set and check the parameters again after the AC drive is replaced.
- All the pluggable components must be plugged or removed only after power-off.
- The rotating motor generally feeds back power to the AC drive. As a result, the AC drive is still charged even if the motor stops, and the power supply is cut off. Thus ensure that the AC drive is disconnected from the motor before starting repair or maintenance on the AC drive.



#### WARNING

- The running motor could feed power to inverter, even though the motor stop and power off. So please make sure cut the connect between motor and inverter.

## 1.2 Notes

### 1.2.1 RCD Request

The running equipment could produce large leak current which pass the protect earth conductor, please install the B type RCD in the power supply side. Please consider the equipment could produce transient and steady state, please choose the special RCD with control higher harmonic function or general use RCD with after-current.

### 1.2.2 Insulation Checking of Motors

Before using the drive, the insulation of the motors must be checked, especially, if it is used for the first time, if it has been stored for a long time or regularly check. This is to reduce the risk of the drive from being damaged by the poor insulation of the motor. When checking ,must make sure the motors and the drive is separated, Please use 500V insulation tester to measure the insulating resistance. It should not be less than 5MΩ.

### **1.2.3 Motor Thermal Protection**

If the ratings of the driven motor are not in compliance with the drive, especially, the drive rated power more than motor rated power, be sure to adjust the protective threshold or to install thermal relay before the motor to ensure the motor is properly protected.

### **1.2.4 Operate Above Power Frequency**

This drive can provide 0Hz~3200Hz output frequency. If the user need to run the motor above 50hz frequency, please consider the affordability of mechanical devices.

### **1.2.5 The Mechanical Device Resonance**

The drive system may encounter mechanical resonance with the load when operating within certain band of output frequency. Skip frequencies have been set to avoid it.

### **1.2.6 Motor Heat and Noise**

The output voltage is in PWM wave with some harmonics. Therefore, temperature rise, noise and vibration of motor are higher than 50Hz.

### **1.2.7 Varistors or Capacitors Used to Improve the Power Factor**

Don't connect any varistor or capacitor to the output terminals of the drive, because the drive's output voltage waveform is PWM, otherwise tripping or damaging of components may occur; in addition, don't install circuit breaker or contactor at the output side of the drive.

### **1.2.8 Circuit Breakers Connected to the Input/Output of the Drive**

If contactor is connected between the input power supply and the motor, Please don't use contactor to control drive start-stop. If it must be done, interval time should not less than one-hour. If frequently charging and discharging, the life of the internal capacitance of the drive will be reduced. If circuit breaker or contactor needs to be connected between output side of the drive and the motor, be sure to operate these circuit breakers or contactor when the drive has no output, to avoid damaging of the drive.

## **1.2.9 Using Outside the Range of Rated Voltage**

The drive is unsuitable to be used out of the specified range of operation voltage; otherwise, it may be damaged. If need, please use suitable voltage regulation device.

### **1.2.10 Change From 3-phase To 2-phase**

It is not recommended to change the drive from 3-phase input to 2-phase input. Otherwise it will lead to failure or damaged.

### **1.2.11 Protection Against Lightning Strike**

There are transient surge suppressors inside the Drive which protects it against lightning strike. Department for frequent thunder and lightning, users should install the drive front-end protection.

### **1.2.12 Derating Due to Altitude**

Derating must be considered when the drive is installed at high altitude, greater than 1000m. Because of the thin air, the cooling effect of drive is deteriorated. Please contact our technical advice in this case.

### **1.2.13 Special Usage**

If users need the wiring diagram, such as common DC bus, without in the manual, Please consult our company.

### **1.2.14 Disposing Unwanted Drive**

The capacitors may explode when they are burnt. Poisonous gas may be generated when the plastic parts like front covers are burnt. Disposing method: Please dispose the Drive as industrial waste.

### **1.2.15 Adaptable Motor**

1.The standard adaptable motor is adaptable four-pole squirrel-cage asynchronous induction motor or PMSM. For other types of motor, select a proper AC drive according to the rated motor current.

2. The cooling fan and rotor shaft of non-variable-frequency motor are coaxial, which results in reduced cooling effect when the rotational speed declines. If



variable speed is required, add a more powerful fan or replace it with variable-frequency motor in applications where the motor overheats easily.

3. The standard parameters of the adaptable motor have been configured inside the AC drive. It is still necessary to perform motor auto-tuning or modify the default values based on actual conditions. Otherwise, the running result and protection performance will be affected.

4. The AC drive may alarm or even be damaged when short-circuit exists on cables or inside the motor. Therefore, perform insulation short-circuit test when the motor and cables are newly installed or during routine maintenance. During the test, make sure that the AC drive is disconnected from the tested parts.



## Chapter 2 Product Information

### 2.1 Naming Rule

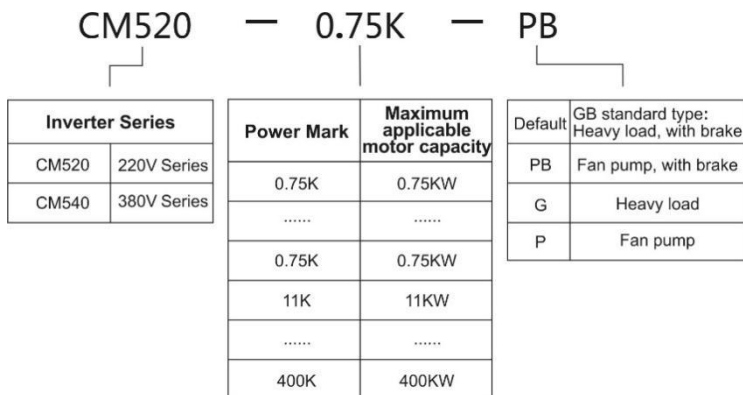

Figure 2-1 Naming Rule

### 2.2 Nameplate



Figure 2-2 Nameplate

The machine case structure of CM540 type:

Voltage classes	Three phase 380V
Model	Type of machine case
0.4~11kW	Plastic structure
15~450kW	Metal plate structure

## 2.3 Electric Date

Table2-1 CM540 Inverter Model and Technology Date

Inverter Model	P capacity(kVA)	Input C(A)	Output C(A)	Adopter motor(kw)
CM540-0.75K	1.5	3.4	2.1	0.75/1.5PB
CM540-1.5K	3.0	5.0	3.8	1.5/2.2PB
CM540-2.2K	4.0	5.8	5.1	2.2/3.7PB
CM540-4.0K	5.9	10.5	9/13	3.7/5.5PB
CM540-5.5K	8.9	14.6	13/17	5.5/7.5PB
CM540-7.5K	11.0	20.5	17/25	7.5/11PB
CM540-11K	17.0	26.0	25/32	11/15PB
CM540-15K	21.0	35.0	32/37	15/18.5PB
CM540-18.5K	24.0	38.5	37/45	18.5/22PB
CM540-22K	30.0	46.5	45/60	22/30PB
CM540-30K	40.0	62.0	60/75	30/37PB
CM540-37K	57.0	76.0	75/91	37/45PB
CM540-45K-G	69.0	92.0	91/112	45/55P
CM540-55K-G	85.0	113.0	112/150	55/75P
CM540-75K-G	114.0	157.0	150/176	75/93P
CM540-90K-G	134.0	180.0	176/210	93/110P

CM540-110K-G	160.0	214.0	210/253	110/132P
CM540-132K-G	192.0	256.0	253/304	132/160P
CM540-160K-G	231.0	307.0	304/340	160/185P
CM540-185K-G	242.0	350.0	340/377	185/200P
CM540-200K-G	250.0	385.0	377/426	200/220P
CM540-220K-G	280.0	430.0	426/465	220/250P
CM540-250K-G	355.0	468.0	465/520	250/280P
CM540-280K-G	396.0	525.0	520/585	280/315P
CM540-315K-G	445.0	590.0	585/650	315/350P
CM540-350K-G	500.0	665.0	650/725	350/400P
CM540-400K-G	565.0	785.0	725/820	400/450P

## 2.4 Technology Specifications

Table2-2 Inverter Technology Specifications

Item		Specifications		
Basic functions	Maximum frequency	Vector control:0~300Hz V/F control:0~3200Hz		
	Carrier frequency	0.5kHz~16kHz The carrier frequency automatically adjusted based on the load features.		
	Input frequency resolution	Digital setting:0.01Hz Analog setting: maximum frequency×0.025%		
	Control mode	Sensor less Open-loop vector control ( SVC ) Closed-loop vector control ( FVC ) V/F control		
	Startup torque	G type:0.5Hz/180% ( SVC ) ; 0Hz/200% ( FVC ) P type:0.5Hz/100%		
	Speed range	1:100 ( SVC )	1:1000 ( FVC )	
	Speed stability accuracy	±0.5% ( SVC )	±0.02% ( FVC )	

Torque control response and precision	Response time 5ms, precision $\pm 5\%$ ( FVC )
Overload capacity	G type:150% rated current 60s;180% rated current 3s.P type:120% rated current 60s;150% rated current 3s.
Torque boost	Automatic torque boost; Manual torque boost 0.1%~30.0%
V/F curve	Three modes: Straight-line V/F curve; Multi-point V/F curve; N-power type V/F curve ( 1.2-power、1.4-power、1.6-power、1.8-power、2-power ) .
V/F separation	2 modes: complete separation ,half separation
Ramp mode	Straight-line ramp and S-curve ramp Four kinds of acceleration/deceleration time with the range of 0.0~6500.0s
DC injection braking	DC braking frequency:0.00Hz~maximum frequency braking time:0.0s~36.0s Braking action current value:0.0%~100.0%
Jog control	Jog frequency range:0.00Hz~50.00Hz Jog acceleration and deceleration time : 0.0s~6500.0s
Simple PLC, multistage speed operation	It implements up to 16 speeds via the simple PLC function or combination of DI terminal states.
Built-in PID	It can keep constant output voltage automatically when the mains voltage changes.
Automatic voltage regulation ( AVR )	Automatically maintain a constant output voltage when grid voltage changes
Over voltage /Over current loss of speed control	Automatic limit of the current and voltage during the operation ,prevent frequent over current and overvoltage trip
Rapid current limit	Minimizing over-current fault , Protect the normal operation of converter.

	Torque limit and control	"Excavator" characteristics , automatic limit of the torque during the operation , to prevent frequent over-current trip; Closed-loop vector mode torque control can be achieved.
Individualized function	High performance	Based on high performance of current vector control technology to achieve asynchronous motor and synchronous motor control.
	Power dip ride through	The load feedback energy compensates the voltage reduction so that the AC drive can continue to run for a short time.
	Fast current limit	Avoid frequent over-current fault of the frequency Inverter.
	Virtual IO	Five groups of virtual DI/Dos can realize simple logic control.
	Timing control	Timing control function: Time range 0.0Min~6500.0Min.
	Multiple communication protocols	It supports communication via: standard con-Figuration RS-485 ( MODBUS protocols ) ,optional CAN link port ( need EXT2-IO extension card )
	Motor overheat protection	The optional EXT2-IO extension card 2 enables analog input AI3 to receive the motor temperature sensor input (PT100).
	Multiple encoder support	It supports various encoders such as differential encoder, open-collector encoder and push-pull output encoder.
Operation	Running command source	Operation panel、 Control terminals、 Serial communication port , You can perform switchover between these sources in various ways.
	Frequency source	There are a total of 10 frequency sources, such as digital setting, analog voltage setting, analog current setting, pulse setting and serial communication port setting. You can perform switchover between these sources in various ways.

	<p>Auxiliary frequency source</p>	<p>There are ten auxiliary frequency sources. It can implement fine tuning of auxiliary frequency and frequency synthesis.</p>
	<p>Input terminal</p>	<p>Standard:                      5 digital input (S1-S5) terminals ,S5 supports up to 100 kHz high-speed pulse inputs.                      2 analog input (AI) terminals, one of which only AI1 supports 0–10V voltage input and AI2 supports 0–10 V voltage input or 4–20mA current input.                      Expanding capacity:                      3 extended digital input terminal ( S6 , S7 , S8 ) ,                      1 analog input terminal(AI3) that supports 0–10V voltage input and also supports motor temperature PT100 test, and supports injection molding machine signals.</p>
	<p>Output terminal</p>	<p>Standard:                      1 output terminal(SP1) , Optional for the open collector output or high-speed pulse output ( 0~100kHz ) .                      1 relay output terminals ( TA-TB-TC ) .                      1 analog output terminals (A01) , supports 0-20mA current output Or 0~10Vvoltage output.                      Expansion capability:                      1 Open collector output terminals (SP2).                      2 relay output terminals ( TA2-TB2-TC2、TA3-TB3-TC3 ) .                      1 analog output terminals ( A02 ) , supports 0-20mAcurrent output or 0-10V voltage output.</p>
<p>Keyboard operations and accessories</p>		<p>LED display</p>
	<p>Key locking and function selection</p>	<p>5 display the parameter</p>



Keyboard operations and accessories Environment	Protection mode	It can lock the keys partially and completely and define the function range of some keys so as to prevent misuse.
	Optional parts	Motor short-circuit detection at power-on, input/output phase loss protection, over-current protection, overvoltage protection, under-voltage protection, overheat protection and overload protection.
	Installation location	IO expansion cards 1( EXT1-IO ), IO expansion cards 2( EXT2-IO ), differential input and output PG card1(PG1-DIFF)、 push-pull output PG card 2(PG2-OC).
Environment	Altitude	Indoor, free from direct sunlight, dust, corrosive gas, combustible gas, oil smoke, vapor, drip or salt.
	Ambient temperature	Less than 1000m;each rises 1000 m, derating 10% use.
	Humidity	- 10°C~ + 40°C ( Ambient temperature 40°C
	Vibration	Less than 95%RH , no water condenses.
	Storage temperature	Less than 5.9m/s <sup>2</sup> ( 0.6g )

## 2.5 Product Outline and Installation Hole Sizes

### 2.5.1 The Outline Drawing of the Inverter

1.G0.4~G15KW Outline and Outer Size of Hang Machine Plastic Casing Inverter

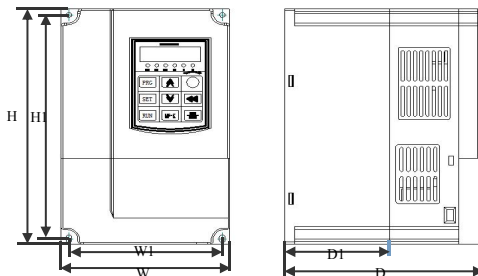

Figure 2-3 CM540 Series 0.4~11KW Outline and Outer Size of Hang Machine Plastic Casing Inverter

Notes: please set the dust shield to the side of the Heat emission hole to prevent the dust into the inverter inside.

2.G18.5~G400KW Outline and Outer Size of Hang Machine Metal Casing Inverter

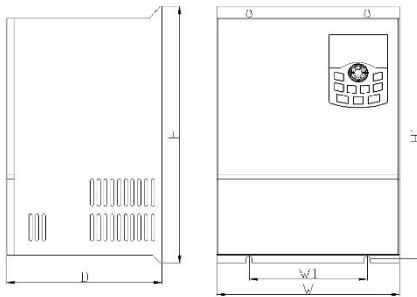

Figure 2-4 CM540 Series 18.5~400KW Outline and Outer Size of metal structure

**2.5.2 The Dimension and Installation Hole Size of Inverter**

**Table 2-3 The Dimension and Installation Hole Size**

Type	Outline size					Mounting aperture	weight
	mm						
	W1	H1	W	D	H		
CM540-0.4K — 4.0K	106	174	118	156	185	ø5	2
CM540-4.0K (out of stock)	148	235	160	176	247	ø5	3.7
CM540-5.5K —11K	148	235	160	176	247	ø5	3.7
CM540-15K — 18.5K	140	323	217	193	335	Ø5	10
CM540-22K	140	350	228	240	360	Φ 5	12
CM540-30K-G — 37K-G	235	450	285	225	463	Φ 8	21
CM540-45K-G — 75K-G	200	590	340	295	614	φ 10	33

CM540-90K-G — 132K-G	280	731	400	295	753	$\phi 10$	70
CM540-160K-G — 220K-G	200	1010	600	400	1050	$\phi 14$	130
CM540-250K-G — 350K-G	300	1090	792	410	1120	$\phi 14$	180
CM540-400K-G	520	1300	800	400	1358	$\phi 14$	200

### 2.5.3 Outline Size of Keyboard

#### 1.The outline size of keyboard

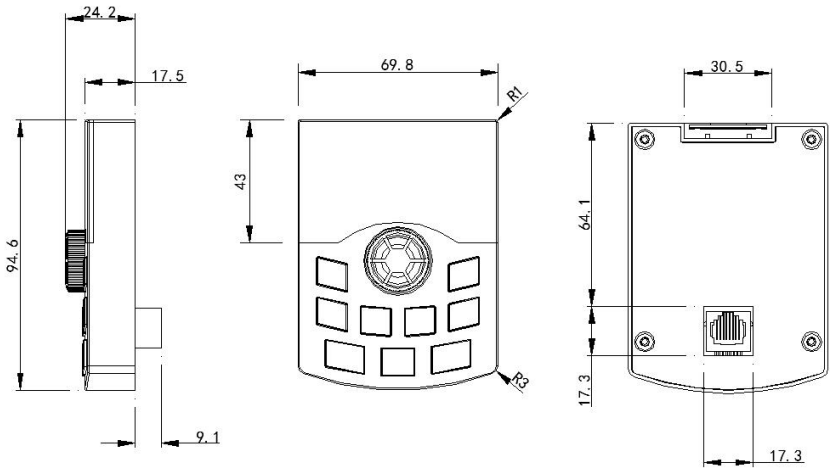

Figure 2-5 The outline size of external keyboard

#### 2.The fixed aperture size of keyboard back ( without keyboard tray )

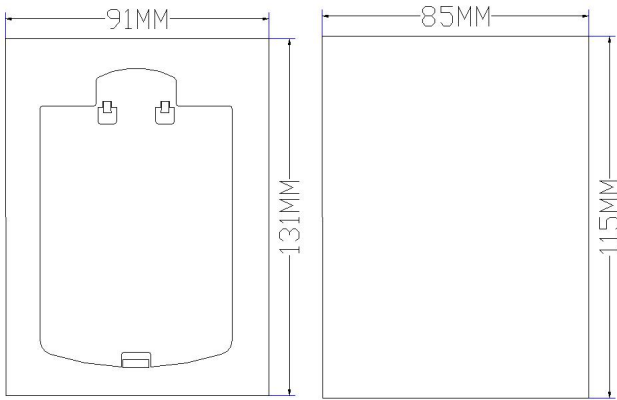

Figure 2-6 The fixed aperture size of keyboard back

2.6 Description of Peripheral Electrical Devices

Table 2-4 Description of peripheral electrical devices

Name	Install Location	Function
Air switch MCCB	Front of input circuits	When downstream devices is over current, breaking the power. ( less than 2 times within 1 min )
Contactor	Between the air switch and the input of frequency inverter	The frequency inverter power on and off, should avoid frequently operating by the contactor or doing direct start-up operation.
AC Reactor	Input side of the frequency inverter	1) Improve the input power factor of the drive 2) Suppress the high-order harmonics of the input side; prevent the other equipment damage for the voltage waveform distortion.

Name	Install Location	Function
Input EMC Filter	Input side of the frequency inverter	1) Reduce the frequency inverter external conduction and radiation disturbance. 2) Reduce interference of conduction flowing from the power to the drive, and improve the anti-interference ability of the drive.
DC Reactor	There is standard dc reactor above G160.	1) Improve the input power factor of the drive 2) Improve efficiency and thermal stability of the whole frequency inverter. 3) Suppress the high-order harmonics of the input side; reduce external conduction and radiation disturbance.
AC Output Reactor	Between the output side of the frequency inverter and motor. Near the drive	The output side of the frequency inverter generally contains more the high-order harmonics. When the distance between the frequency inverter and the motor is far, there is large distributed capacitance in the line, the high-order harmonics may produce resonance in loop, bring two influences: 1) Destroy motor insulation performance, might damage the motor for a long time. 2) Have caused a greater leakage current and the frequency inverter will trip frequently. Generally, when the cables from the frequency inverter to motor are longer than 100m, an output AC line reactor should be used.

The detail specifications of peripheral electrical devices, please reference to the chapter 3 3.2.

## 2.7 Optional Parts of the Inverter

If any optional part is required, specify it in your order.

Table 2-5 Optional parts of the inverter

Name	Model	Function	Remarks
External brake unit	ES100 series	External brake unit above 37KW	
DC reactor		11 ~ 110KW power converter can be equipped with DC reactor; 132 ~ 450KW power converter matching external DC reactor	
Spiral PG card	ES60pg1a	Output rotary encoder interface card, adapter5V power	Full range models available
Differential input PG card	ES60PG2A	OC/ push-pull output encoder interface card, with 1:1 frequency division output, suitable for 12V power supply	Full range models available

### 2.8 The Selection and Size of External DC Reactor

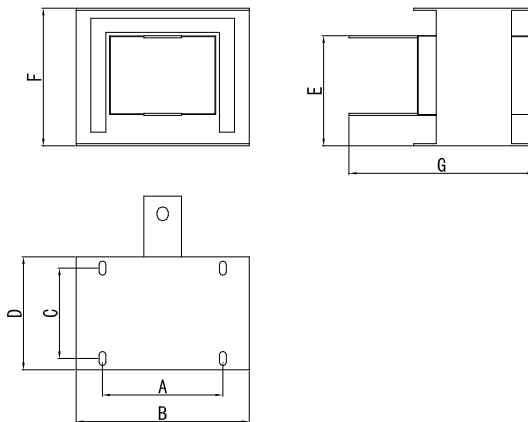

Figure 2-11 diagram of external reactor size

Table 2-6 Selection and size of reactor

Suitable for frequency converter type	A	B	C	D	E	F	G	Fixed hole	Bronze joint aperture
CM540-90K-G 110K-G	160	190	125	161	192	255	195	10*15	12
CM540-132K-G	160	190	125	161	192	255	195	10*15	12

160K-G									
CM540-200K-G 220K-G	190	230	93	128	250	325	200	13*18	15
CM540-250K-G 280K-G	190	230	93	128	250	325	200	13*18	15
CM540-315K-G 355K-G 400K-G	224	250	135	165	260	330	235	12*20	14

The 0.4~37kW inverter of CM540 series don't have external dc reactor terminal.

The G132 and above must use standard external DC reactor along with the cargo when factory arrange the deliver. Users need to remove the short circuit copper bars between the main circuit terminals (+) and P when installation, then the DC reactor could be connected between the (+) and P, there is no pole between the reactor terminals and the inverter terminals (+), P. After installing the DC reactor, the short circuit copper bars between (+) and P short circuit is no longer used.

## 2.9 Selection of Braking Package

1.Value of resistance selection of braking resistance

When braking, the recovered energy of motor is expend on braking resistance.

On the basis of  $U^2/R=P_b$ ;

The U means braking voltage when system brakes stably ( different system, different braking voltage. Generally the 380VAC system uses 700v ) .

$P_b$ ----Braking power

2.The selection of braking resistance's power

In the theory the power of braking resistances same to braking power, but consider the

derate is 70%. We could use this formula: $0.7*Pr=P_b*D$ ;

$Pr$ ----power of resistance;

$D$ ----braking frequency ( The regeneration process accounts for the proportion of

the whole process ) ;

Elevator\Pumping unit-----20%~30%

Uncoil and coil----20 ~30%

Centrifugal machine-----50%~60%

Braking load by accident----5%

General value is 10%.

### 3.Selection of Braking Package

Note: Table 2-5 is the guide data, according to the actual situation, the user can choose different resistance and power, (the resistance must not be greater than the recommended value in the table, but the power could.). The motor’s power in the practical application system, determine the braking resistor, which have relationship with system inertia, deceleration time, potential energy of the load, the customer should select according to the actual situation. The greater the system inertia, the shorter the time required deceleration, braking the more frequent, the braking resistor should have the greater power and the smaller resistance.

Table2-7 Selection of CM540 VFD’s Braking Package

VFD Model	Recommended Braking Resistor Power (W)	Recommended Braking Resistor Resistance (Ω)	Braking Unit	Remark
CM540-0.75K	150W	≥300Ω	Standard build-in	The wiring method please check chapter 3.
CM540-1.5K	150W	≥220Ω		
CM540-2.2K	250W	≥200Ω		
CM540-4.0K	300W	≥130Ω		
CM540-5.5K	400W	≥90Ω		
CM540-7.5K	500W	≥65Ω		
CM540-11K	800W	≥43Ω		



CM540-15K	1000W	$\geq 32\Omega$		
CM540-18.5K	1300W	$\geq 25\Omega$	Optional built-in	
CM540-22K	1500W	$\geq 22\Omega$		
CM540-30K	2500W	$\geq 16\Omega$		
CM540-37K	According to braking unit request	According to braking unit request	External	Use coolmay's braking unit

## 2.10 Frequency Inverter Daily Maintenance

### 1. Daily Maintenance

Many factors such as ambient temperature, humidity, dust, vibration will cause the internal components aging and give rise to the occurrence of potential faults or lessen the service life of the VFD. Therefore, it is necessary to conduct routine maintenance to the VFD.

#### 2. Daily inspection items:

- a) When running, whether the motor has abnormal sound.
- b) When running, whether the motor generates vibration.
- c) Whether the installation environment of the VFD changes.
- d) Whether the cooling fan of the drive is working properly.
- e) Whether the VFD is overheating

#### 3. Daily cleaning:

- a) Reserve the drive in a clean state.
- b) Effectively remove the dust on the surface of the inverter to prevent dust entering the inside of the inverter, especially the metal dust.

c) Effectively clear the oil from the cooling fan.

#### 4. Routine Checking

Check regularly the place which is difficult to check when the drive is running, routine checking items:

- a) Check the air duct, and regularly clean.
- b) Check whether the screws are loose.
- c) Check whether the drive is corroded.
- d) Check whether the terminals have arc traces.
- e) Check whether the main circuit is insulation.

Notes: When using a DC 500V Mega-Ohm-Meter to test insulating resistance, please make sure the main circuit and the frequency inverter is disconnected. please don't use the insulation resistance meter to test the insulation of the control circuit. High voltage test is unnecessary(it has already been conducted before delivery).

#### 5. Replacing of Quick-wearing Parts

The quick-wearing parts of the frequency inverter mainly includes cooling fan and electrolytic capacitors for filters. Their lifetime depends largely on their application environment and maintenance condition. Normally, lifetime is:

Components	Life
Fan	2~3 years
Electrolyte capacitor	4~5 years

The user can decide the replace age limit according to the running time.

##### 1. Cooling fan

Possible cause of damages: wear of the bearing, aging of the fan vanes.

Criteria: Check if there is crack on fan vanes and other parts. When the inverter

is switched on, check if there is any abnormal vibration.

## 2.Filtering Electrolytic capacitors

Possible cause of damages: the quality of input power is bad, the ambient temperature is high, frequent loading jump and aging of electrolyte.

Criteria: Check if there is any leakage of liquids. Check if the safety valve protrudes. Measurement of static capacitance and insulation resistance.

## 3.Storage

After buying the inverter, when store for temporarily and long-term, the following notes is important:

- 1) As far as possible store into the original packaging.
- 2) Long-term storage will cause the deterioration of electrolytic capacitors. Therefore, the inverter must be powered within 2 years, and the conduction time is at least for 5 hours. The input voltage must be boosted gradually to the rated value by the voltage regulator.

## Chapter 3 Mechanical and Electrical Installation

### 3.1 Mechanical Installation

#### 3.1.1 Installation Environment

1.Ambient temperature: The surrounding environment and temperature has great influence on the life of the frequency inverter, the running ambient temperature of the frequency inverter should be within the temperature range of  $-10^{\circ}\text{C}\sim 50^{\circ}\text{C}$ .

2.The frequency inverter should be installed on the surface of the antinflaming goods, there must be enough space for heat dissipation around, install the inverter vertically on the support with the screw.

3.Install in the location where vibration is less than 0.6G, Pay special attention to be away from the punch press and other equipments.

4.Install in the location free of direct sunlight, wet, drops of water.

5.Install in the location Reserve away from corrosive gas ,flammable gas or explosive gas.

6.Install in the location avoid greasy dirt, dust, metal dust.

7.CM540 series inverter should be installed on the fire-proof plate.

Single installation: When the frequency inverter power is less than 22KW, size “A” could not be considered to install, on the contrary, size “A” should be longer than 50mm.

Upper and lower Installation: When two frequency inverters are mounted one on top the other, an heat insulation guide plate should be fixed in between as shown in above Figure.

Power Grade	Installation Size	
	B	A
$\leq 15\text{kW}$	$\geq 100\text{mm}$	No request
18.5kW—30kW	$\geq 200\text{mm}$	$\geq 50\text{m}$
$\geq 37\text{kW}$	$\geq 300\text{mm}$	$\geq 50\text{m}$

### 3.1.2 Installation Attention

When installing, the thermal dissipation should be paid attention to. so please note the following:

1) In order to easy to dissipate the thermal, please install the inverter vertically. But can not be inverted. If there are several inverters in the cabinet, the best method is to install side by side .When two Variable Speed Drives are installed one on top the other, the heat insulation guide plate should be installed between as shown in Figure. 3-1.

2) The requirements on installation space are shown in Figure. 3-1 which should ensure the heat dissipation space of the frequency inverter. Layout should ensure the heat dissipation condition of other components in the cabinet.

3) Mounting bracket must be flame-retardant material.

4) For the location where there is metal powder, the inverter should be mounted outside of the cabinet. If the space is sealed, should make the cabinet having space as large as possible.

## 3.2 Electrical Installation

### 3.2.1 External Electrical Component Selection

Table3-1 CM540 frequency inverter external electrical component selection

VFD Model	Air Switch(A) (MCCB)	Recommend ation Contactor (A)	Recommend ation Input Side Main Circuit Wire(mm <sup>2</sup> )	Recommend ation On put Side Main Circuit Wire(mm <sup>2</sup> )	Recommend ation Control Circuit Wire
CM540-0.75K	16	10	2.5	2.5	1.0
CM540-1.5K	16	10	2.5	2.5	1.0
CM540-2.2K	25	16	4.0	4.0	1.0
CM540-4.0K	32	25	4.0	4.0	1.0
CM540-5.5K	40	32	4.0	4.0	1.0
CM540-7.5K	40	32	4.0	4.0	1.0

CM540-11K	63	40	4.0	4.0	1.0
CM540-15K	63	40	6.0	6.0	1.0
CM540-18.5K	100	63	6	6	1.5
CM540-22K	100	63	10	10	1.5
CM540-30K	125	100	16	10	1.5
CM540-37K	160	100	16	16	1.5
CM540-45K-G	200	125	25	25	1.5
CM540-55K-G	200	125	35	25	1.5
CM540-75 K-G	250	160	50	35	1.5
CM540-90 K-G	250	160	70	35	1.5
CM540-110K-G	350	350	120	120	1.5
CM540-132K-G	400	400	150	150	1.5
CM540-160K-G	500	400	185	185	1.5
CM540-185K-G	600	600	150*2	150*2	1.5
CM540-200K-G	600	600	150*2	150*2	1.5
CM540-220K-G	800	600	185*2	185*2	1.5
CM540-250K-G	800	800	185*2	185*2	1.5
CM540-280K-G	800	800	150*3	150*3	1.5
CM540-315K-G	800	800	150*4	150*4	1.5
CM540-350K-G	1000	1000	150*4	150*4	1.5
CM540-400K-G	1000	1000	150*4	150*4	1.5

### 3.2.2 Wiring

#### 1. 0.75KW-400KW basic operation wiring

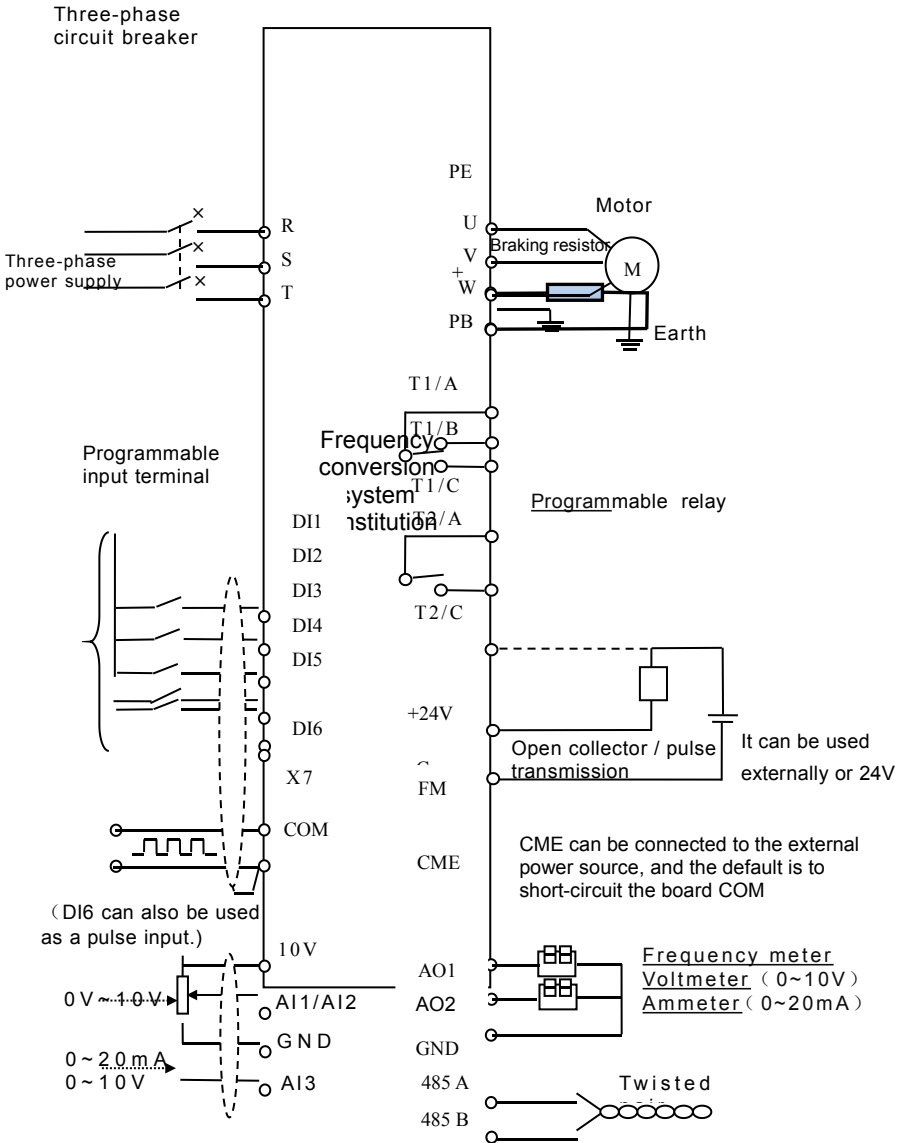



Diagram 3-5 Inverter wiring diagram

Notes:

- a ) terminal ⊙ means main loop terminal, ○ means control loop terminal.
- b ) 0.75~37kw match standard built-in braking unit, no need to add other one; 45~110kW option built-in braking unit.
- c ) 132kW and above match standard external dc reactor.
- d ) Braking resistance selected according to user request, and detail please check braking resistance selection.

**3.2.3 Main Circuit Terminals and Wiring**

	<b>Danger</b>
<ol style="list-style-type: none"> <li>1. Before wiring, make sure the power switch is OFF, otherwise, can lead to electric shock.</li> <li>2. Only trained professionals can do wiring, so as to avoid the risk of the drive damage and the personal injury.</li> <li>3. The drive must be properly earthed to reduce electrical accident and fire.</li> </ol>	

	<b>Attention</b>
<ol style="list-style-type: none"> <li>1. Ensure that the drive's rated input voltage is identical with the AC supply voltage before using it.</li> <li>2. Confirm the motor and the drive adaptation, otherwise, make damage the drive or cause the motor tripping.</li> <li>3. It is prohibited to connect the AC supply cables to the drive's terminals U, V and W.</li> <li>4. Braking resistor can not be directly connected to the DC bus (+), (-).</li> </ol>	

Introduction of main circuit terminals of the 3-phase frequency inverter



Sign	Name	Description
R、S、T	3-phase power supply input terminals	3-phase 380V AC supply connections
( + ) ( - )	DC bus wire(+,-) terminals	DC bus input common point, reserved terminals for above 15kw external brake kits.
( + ) PB	Brake resistor wiring terminals	30kW and below, the brake resistor connected points.
P、( + )	Add reactor wiring terminals outside	37kW and above add reactor connect point outside.
U、V、W	The frequency inverter output terminals	Connect 3-phase motor
	Earth terminal	Earth terminal

#### Wiring Notes:

##### a)Input Power R、S、T:

The frequency inverter's input side wiring is not requirements in phase order.

##### b)DC bus terminals (+), (-)

Notice: Wiring can only be done after the drive's AC power is cut off, then waiting for at least 5mins and confirming the voltage between DC bus terminals plus and minus is below DC 36V.

When choosing external braking kits more than 37KW for frequency inverter, do not mistake the terminals (+),(-), otherwise, can lead to the drive damage and fire.

When the cables from the frequency inverter to motor are longer than 10m, multi-stranded cables or close two-lane parallel wiring should be used.

Braking resistor can not be directly connected to the DC bus, otherwise, cause the risk of the drive damage and fire.

##### c)Brake resistor terminals (+), PB:

75W (0.75-22KW standard built-in configuration, 30-75KW can optionally select built-in configuration) or lower version needs to confirm the models with built-in braking units, the braking resistor terminals are effective.

Selection of braking resistor should refer to the recommended value, and wiring distance should be less than 5m. so as to reduce the risk of the drive damage.

d)Add reactor connect terminal outside P, (+):

G37 and above frequency inverter, adding reactor outside , remove the connected piece between P and (+), then connect the reactor to the two terminals.

e)Frequency Inverter Output Side U. V. W :

The capacitors or surge absorbers can not be connected to the output side of the drive. Otherwise cause the frequency inverter to trip frequently or even be damaged.

Because motor cable is too long, the impact of distributed capacitance produces electrical resonance, which led to the damage of the motor insulation, the drive tripping for a greater leakage current. When the cables from the drive to motor are longer than 100m, a AC input reactor should be used.

f)Earth Terminal  $\perp$

The terminal must be properly earthed, ground resistance must be less than 0.1Ω. Otherwise, lead to equipment abnormal operation or damaged.

Notice: It is prohibited to share the earth terminal E and the power zero line terminal N.

### 3.2.4 Control Circuit and Wiring

1.Control circuit terminals drawing:

CANH	CANL	CGND	+13V	A12	A13	AO2	DI2
485A	485B	GND	+10V	A11	AO1	DI1	CME

DI3	DI4	DI5	DI6	T1/C	T1/B	T1/A
COM	FM	OP	+24V	T2/C	T2/A	PE

## Diagram 3-6 Control circuit terminals drawing

## 2. Description of Control Circuit Terminals:

Table 3-2 Description of CM540 Inverter Control Circuit Terminals

Type	Terminal Symbol	Terminal Name	Function Description
Power	10V-GND	10V power supply	Provide +10V power for outside, normally used as working power of the external potentiometer, potentiometer resistance range: 1K $\Omega$ ~ 5K $\Omega$ . Max output current: 10mA
	24V-COM	24V power supply	Provide +24 V power for outside, generally used as the power of digital input and output terminals and external transducers. Max output current: 200mA
	OP	Input terminal of external power supply	Connect to +24 V by default. When S1~S5 need to be driven by external signal, OP needs to be connected to external power supply, JP1 will not jump to any terminal.
Analog Input	AI1-GND	Analog input terminal 1	1. Input voltage range: DC 0V~10V 2. Input resistance: 22K $\Omega$
	AI3-GND	Analog input terminal 2	1. Input range: DC 0V~10V or 4mA~20mA, selected by jumper "JP2" on the control board. 2. Input resistance: input voltage 22K $\Omega$ , input current 500 $\Omega$ .
Digital Input	DI1-COM	Digital input 1	Optical coupling isolation, compatible with dual polarity input Resistance input: 2.4 k $\Omega$ Voltage range for level input: 9~30 VS5 can be used for high-speed pulse input. Maximum input frequency: 100 kHz
	DI2-COM	Digital input 2	
	DI3-COM	Digital input 3	
	DI4-COM	Digital input 4	
	DI6-COM	Digital input 5	
Analog Output	FM-CME	Analog output 1	Output voltage or current could be selected by the JP9 jumper of the control board. Output voltage range:

			DC 0V~10V Output current range: DC 0~20mA
Digital Output	AO1/AO2	Digitaloutput1	Open collector output / high-speed pulse output, limited by function code P5-00; As high-speed pulse output, the highest output frequency is 100KHZ; Output voltage range: DC 0V~24V Max output current is 50mA. Note that CME and COM are internally insulated, but they are shorted by JP3 jumper externally. If you want to drive by external power, JPS no need to jump any external CME connect power supply.
Relay Output	TA-TB	Normal close terminals	Contact driving capacity: AC 250V , 3A , COS $\phi$ =0.4.DC 30V , 1A
	TA-TC	Normal open terminals	
Auxiliary Interface	J3	Extension card	28 root contact pins, support expand card
	J4	PG card interface	18 root contact pins, support 5V power supply differential input PG card( PG1-DIFF ), 15V power supply OC/push-pull input PG card 2(PG2-OC) , same time just support one.
	J2	Operation panel interface	Connect to external operation panel.
communication Terminal	485-485+	RS485 hardware circuit	Support standard MODBUS Communication

### 3.Control panel jumper description

Jumper No.	Jumper Location	Description
J15	Short circuit OP1、 OP	OP connected to external power supply
	Short circuit OP1 、	OP1 is connected to 24V, DI and COM are short-circuited

J4	Short circuit 2、3 pin	AI3 analog input choose -voltage V
	Short circuit 1、2 pin I	AI3 analog input choose –current I
J3	Short circuit 2、3 pin V ( Factory setting )	AO1 analog input choose -voltage V
	Short circuit 1、2 pin I	AO1 analog input choose –current I
JP6	Short circuit 1、2 pin	Rs485 communication is connected impedance matching
	Short circuit 2、3 pin	Rs485 communication is not connected impedance matching

4.wiring description of control terminals:

a) Analog input terminals:

Weak analog voltage signal is particularly vulnerable to external interference, so it is generally necessary to use as short as possible shielded cable, wiring is less than 20m, shown in Figure.3-7. When analog signal is seriously interfered in some occasion, a filter capacitors or a ferrite cores should be used in the analog signal source side, shown in Figure.3-8.

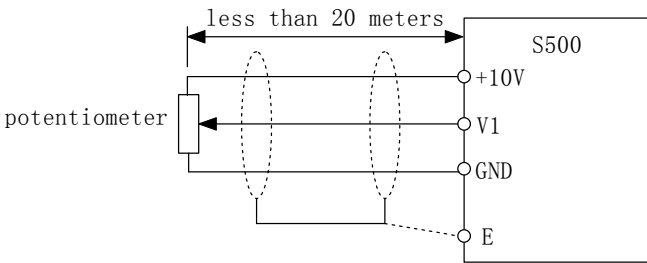

Diagram 3-7 Analog input terminal wiring diagram

In this method, optocoupler breaker;

Internal power supply, JP15 jump to 24v;

External power supply, JP15 jump to OP, the OP terminal need to connect +VCC.

When terminal input on connection:

And if the setting property of P4-38 、 P4-39 is positive logic, which is corresponding to start using function of terminal setting;

And if the setting property of P4-38、 P4-39 is anti-logical, which couldn't start use the terminal setting.

When terminal input on unconnected:

And if the setting property of P4-38、 P4-39 is positive logic, which couldn't start use the terminal setting.

And if the setting property of P4-38、 P4-39 is anti-logical, which is corresponding to start

## Chapter 4 Keyboard Operation and Display

### 4.1 Introduction of Keyboard Operation and Display Interface

Through the keyboard operation panel, we could modify the functional parameter to the frequency inverter, monitor the working condition of the frequency inverter and perform the operational control (start, stop) of frequency inverter, its outline and functional zone are as follows.

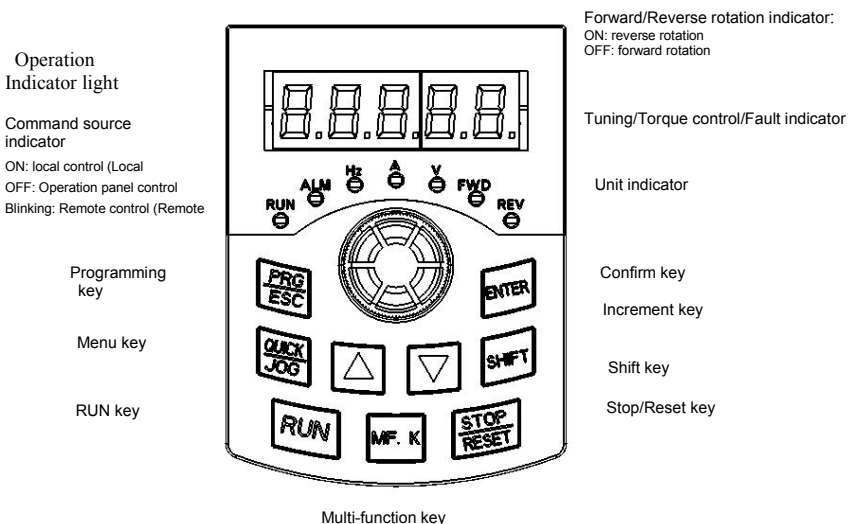

Figure 4-1 Diagram of the operation panel

#### 1. Description of Indicators

**RUN:ON** indicates that the AC drive is in the running state, and **OFF** indicates that the AC drive is in the stop state.

**LOCAL/REMOT**: It indicates whether the AC drive is operated by means of operation panel, terminals or communication. , off indicates operation panel control, on indicates terminal control. Blinking indicates communication control.

**FWD/REV**: On indicates reverse rotation.

**TUNE/TC**: When the indicator is ON, it indicates torque control mode. When the indicator is blinking slowly, it indicates the auto-tuning state. When the indicator

is blinking quickly, it indicates the fault state.

## 2. Unit Indicators:

Hz: unit of frequency

A: unit of current

V: unit of voltage: RPM ( Hz+A ) : unit of rotational speed

% ( A+V ) :percentage

## 3. Digital Display:

The 5-digit LED display is able to display the set frequency, output frequency, monitoring data and fault codes.

## 4 . Description of Keys on the Operation Panel:

Table 4-1 Key Function Menu

Key	Name	Function
PRG/ESC	Programming	Enter or exit Level I menu.
ENTER	Confirm	Enter the menu interfaces level by level, and confirm the
▲	Increment	Increase data or function code.
▼	Decrement	Decrease data or function code.
SHIFT	Shift	Select the displayed parameters in turn in the stop or running state, and select the digit to be modified when modifying parameters.
RUN	Run	Start the AC drive in the operation panel control mode.
STOP RESET	Stop/Reset	Stop the AC drive when it is in the running state and perform the reset operation when it is in the fault state. The functions of this key are restricted in F7-02.
MF.K	Multifunction	Perform function switchover (such as quick switchover of command source or direction) according to the setting of F7-01.
QUICK/JOG	Menu mode selection	Perform switchover between menu modes according to the setting of PP-03.



## 4.2 Display Mode and Switching Operation of Parameter Group

The setting of parameter display mode is convenient for the user to check different function parameter, according to actual requirement. Three ways of parameter display as below.

Parameter group	Manu display	Description
Mode of function parameter	--P--	Display inverter function parameters: P0~PP、H0~PC、U
Mode of user customized parameter	--H--	User could customize individual function parameter (maximum customized 32, and confirm display function parameter through PE.
Mode of user changed parameter	--C--	Inverter auto arrange, if the parameter is different with the factory parameter.

The property of parameter group display is limited by PP-02 and PP-03. As follows;

PP-02	The property of parameter group display		Factory setting	11
	Setting range	The unit	D group display selection	
		0	Not display	
		1	Display	
		Decade	C group display selection	
		0	Not display	
1		Display		
PP-03	Display selection of special parameter mode		Factory setting	0
	Setting range	The unit	User customs parameters display selection	
		0	Not display	
		1	Display (--u--)	
		Decade	User changes parameters display selection	

		0	Not display
		1	Display(--c--)

When display selection of special parameter mode(PP-03) have one display, we could use MENU key witch in different parameter display mode. The operation diagram of MENU parameter group witch is as follows:

### 4.3 Viewing and Modifying Function Codes

Basic function code group is inverter's whole function code, after entering it is I grade menu.

The operation panel of the CM540 adopts three-level menu. The three-level menu consists of function code group (Level I), function code (Level II), and function code setting value (level III), as shown in the following Figure. Figure 4-3 Operation procedure on the operation panel.

Explain: You can return to Level II menu from Level III menu by pressing MODE or ENTER. After you press ENTER, the system saves the parameter setting first, and then goes back to Level II menu and shifts to the next function code. After you press MODE, the system does not save the parameter setting, but directly returns to Level II menu and remains at the current function code.

For example: change the function code P3-14 from 10.00Hz to 12.00Hz

In Level III menu, if the parameter has no blinking digit, it means that the parameter cannot be modified. This may be because:

- 1/Such a function code is only readable, such as, actually detected, parameter and running record parameter.
- 2/Such a function code cannot be modified in the running state and can only be changed at stop.

### 4.4 The Operation Mode of User Customized Parameter

The user-defined menu is set to facilitate viewing and modifying of commonly used function codes. In this mode, the display parameter uF 3.02 indicates function code P3-02. You can also modify parameters in this mode as in

common editing state. After the mode is switched over to -User , level II menu is displayed.

The user-defined parameters are included in group HE. If HE is set to F0.00, it indicates that no function codes are available. A maximum of 30 parameters can be included in group HE. If "NULL" is displayed, it indicates that the user-defined menu is null.

A total of 16 parameters are pre-stored in the user-defined menu, as listed in the following table.

P5-01:control mode source selection	P5-02:Command
P5-03:Main frequency source X selection	P5-07:Frequency source selection
P5-08:Preset frequency	P5-17:Acceleration time
P5-18:Acceleration time	P3-00:V/F curve setting
P3-01:Torque boost	P4-00:S1 function selection
P4-01:S2 function selection	P4-02:S3 function selection
P5-04:SP2 output selection	P5-07:A01 output selection
P6-00:Start mode mode	P6-10:Stop

You can edit the user-defined menu based on actual requirements.

#### 4.5 User Modified Function Code

In you modified menu, only the parameters that are modified to a non-default value are displayed. The menu is generated by the AC drive automatically. After the mode is switched over to User modified function code, level II menu is displayed

#### 4.6 Definition and Operation of the Multifunction Key (MF.K)

You can define the function (command source switchover or rotation direction switchover) of the multifunction key in F7-01. For details, see the description of P7-01.

#### 4.7 Viewing Status Parameters

In the stop or running state, you can press“>>/SHIFT” on the operation panel to display status parameters. Whether parameters are displayed is determined by the binary bits of values converted from the values of P7-03, P7-04, and P7-05 in the hexadecimal format.

In stop state, a total of 13 status parameters can be displayed, as listed in the following table.

P7-05	LED display stop parameters	Bit00: Set frequency(Hz) Bit01: Bus voltage (V) Bit02: S input status Bit03: DO output status Bit04: AI1voltage (V) Bit05: AI2voltage (V) Bit06: AI3voltage (V)	Bit07: Count value Bit08: Length value Bit09: PLC stage Bit10: Load speed Bit11: PID setting Bit12: HDI Pulse setting frequency (kHz)	33	√
-------	-----------------------------	--	---	----	---

To switchover and display the selected parameter by keyboard order.

In running state, five running status parameters are displayed by default, and you can set whether other parameters are displayed by setting P7-03 and P7-04, as listed in the following table.

P7-03	LED display running parameters1	Bit00: Running frequency1(Hz) Bit01: Set frequency(Hz) Bit02: Bus voltage Bit03: Output voltage Bit04: Output Curren(A) Bit05: Output power(KW)	Bit08:DO output status Bit09:AI1voltage(V) Bit10: AI2voltage(V) Bit11: AI3voltage(V) Bit12: Count value Bit13: Length value Bit14: Load speed	1F	√
-------	---------------------------------	--	---	----	---

		Bit06: Output torque(%) Bit07: S input status	display Bit15: PID setting		
P7-04	LED display running parameters2	Bit00: PID feedback Bit01: PLC stage Bit02: HDI input frequency Bit03: Running Frequency2(Hz) Bit04: Residue running time Bit05: DI1 voltage before correction Bit06: DI2voltage before correction Bit07: DI3 voltage before correction	Bit08: Linear speed Bit09: Current power-on time (Hour) Bit10: Current running time (Minute) Bit11: HDI input frequency Bit12: Communication setting value Bit13: Encoder feedback speed Bit14: Main frequency A display(Hz) Bit15:Auxiliary frequency B display(Hz)	0	√

When the AC drive is powered on again after power failure, the parameters that are selected before power failure are displayed.

Select the required parameters by pressing . Set the values of the parameters by referring to the following example.

1. Determine the parameters to be displayed. Running frequency, Bus voltage, Output voltage, Output current, Output frequency, Output torque, PID feedback, Encoder feedback speed

2. Set the binary data.

P7-03: 0000 0000 0111 1101B, P7-04: 0010 0000 0000 0001B

3. Convert the binary data to hexadecimal data:

P7-03: 007DH,P7-04: 2001H

The values displayed on the operation panel are respectively P7-03:H.007d ,

F7-04:H.2001

## 4.8 Starting or Stopping the AC Drive

### 4.8.1 Selecting the Start/Stop Command Source

There are three start/stop command sources, namely, operation panel control, terminal control, and communication control. You can select the command source in P5-02.

		Command Source Selection	Default:0	Description
P0-02	Setting Range	0	Operation panel control (Indicator OFF)	Press RUN、STOP to start or stop the AC drive.
		1	Terminal control (indicator ON)	S terminal needs to be defined as the run/stop terminal.
		2	Communication control (Indicator Blinking)	The Modbus-RTU communication protocol is used.

#### 1.Operation Panel Control

Control inverter through operation panel, use function code P0-02=0. After you press RUN, the AC drive starts running (the RUN indicator is ON). After you press STOP, when the AC drive is in running state, the AC drive stops running (the RUN indicator is OFF)

#### 2.Terminal Control

This control mode is applicable to scenarios where the PID switch or

electromagnetic button is used to start or stop the application system or scenarios where the dry contact signal is used to start or stop the AC drive. The switch signal mode is set in P4-11. The input terminal of the start/stop signal is set in P4-00 to P4-09. For details, see the description of P4-11 and P4-00 to P4-09.

Example 1:

To use the DIP switch as the start/stop source, and allocate the forward rotation switch signal to DI2 and the reverse rotation switch signal to DI3, perform the setting as shown in the following Figure.

Figure 4-4 Setting of using the electromagnetic button for start/stop

In the preceding Figure, when SB1 is ON, the AC drive instructs forward rotation; when SB1 is OFF, the AC drive stops. When SB2 is ON, the AC drive instructs reverse running; when SB2 is OFF, the AC drive stops. If SB1 and SB2 are ON or OFF simultaneously, the AC drive stops.

Example 2:

To use the electromagnetic button as the start/stop source, and allocate the start signal to DI2, stop signal to DI3 and reverse rotation signal to DI4, perform the setting as shown in the following Figure.

In the preceding Figure, SB1 must stay ON during normal start and running. The AC drive stops immediately after SB1 becomes OFF. The signals from SB2 and SB3 become valid once they become ON. The running state of the AC drive is determined by the final actions on the three buttons.

### 3.Communication Control

The most common configuration is when the host computer is used to control running of the AC drive by means of communication, such as the RS485, PROFIBUS-DP, CANlink, and CANopen. The CM540 interacts with the user programmable card also by means of communication.

Install a matching communication card in the multifunction extension port, and set P5-02 to 2. Then, you can start or stop the AC drive in communication mode. The following Figure shows the setting method.

Diagram 4-6 Setting for start/stop using the communication control mode

When Pd-04 is set to a non-zero number, the function of automatic AC drive stop upon communication timeout is enabled. This prevents uncontrollable AC drive

running due to faults of the communication cable or the host computer.

The communication port of the AC drive supports the Modbus-RTU protocol, and the communication is implemented only when the host computer supports the Modbus-RTU master station protocol.

#### **4.8.2 Start Mode**

The CM540 supports three start modes, namely, direct start, rotational speed tracking restart, and pre-excited start (asynchronous motor), set in P6-00.

**Direct start** :It is applicable to small-inertia load. The frequency curve in this mode is shown in the following Figure. DC braking before the start is applicable to drive of load such as elevator and crane. Startup frequency is applicable to drive with burst start under start torque, such as cement mixer.

**P6-00 = 1 (Rotational speed tracking restart)** It is applicable to large-inertia load. The frequency curve in this mode is shown in the following Figure. If the load motor is still rotating due to the inertia when the AC drive starts, this mode is used to prevent start over current

**P6-00 = 2 (Pre-excited start)**

It is applicable only to inductive asynchronous motor. The AC drive performs pre-excitation before start, improving quick response of the motor and meeting the requirements of short acceleration time. The frequency curve in this mode is shown in the following Figure

#### **4.8.3 Stop Mode**

The AC drive supports two stop modes, decelerate to stop and coast to stop, set in P6-10.

#### **4.8.4 Timing Stop**

The CM540 supports timing stop. This function is enabled by P8-42 and the timing duration is determined by P8-43 and P8-44.

You can set the timing duration by means of analog input (such as potentiometer



signal). For details, see the description of P8-43.

### 4.8.5 JOG Running

In certain applications, the AC drive needs to run in low speed temporarily to facilitate equipment test or other commissioning operations. In this case, you can set the AC drive to perform JOG running.

#### 1. Parameter Setting and Operation of JOG Running in Operation Panel Control

Set the parameters according to the preceding Figure. In stop state of the AC drive, hold down MF.K, and the AC drive starts JOG running. After you release MF.K, the AC drive decelerates to stop.

To perform reverse JOG, set P7-01 to 4 and P8-13 to 1. Hold down MF.KK and the AC drive starts reverse JOG running.

#### 2. Parameter Setting and Operation of JOG Running in DI Terminal Control

For equipment that requires frequent JOG operations, such as textile machine, it is more convenient to control JOG running by using keys or buttons. To achieve convenient control, perform the setting according to the following Figure:

After performing the setting according to the preceding Figure, press the FJOG button in stop state of the AC drive. Then, the AC drive starts forward JOG. After you press the FJOG button again, the AC drive decelerates to stop.

## 4.9 Setting the Running Frequency

The AC drive provides two frequency sources, namely, main frequency source A and auxiliary frequency source B. You can select one frequency source and switch over between the two sources. You can also perform superposition on the two sources by setting the calculation formula to meet different control requirements of different scenarios

### 4.9.1 Frequency Setting by the Main Frequency Source

There are ten setting modes of main frequency sources, digital setting (UP/DOWN modification, non-retentive at power failure), digital setting (UP/DOWN modification, retentive at power failure), AI1, AI2, AI3, HDI pulse setting, multi-reference, simple PLC, PID and communication setting. You can

select one in P5-03.

According to the preceding Figure, the running frequency of the AC drive can be set by means of function codes, manual adjustment, analog input, multi-speed terminal, external feedback signal, internal PID regulator, or the host computer. Set the corresponding function codes of each frequency setting mode, as shown in the preceding Figure.

#### 4.9.2 Frequency Setting by the Auxiliary Frequency Source

The frequency setting by the auxiliary frequency source is the same as the frequency setting by the main frequency source. You can set the auxiliary frequency source in P5-04.

The relationship between the target running frequency and the main frequency source and auxiliary frequency source is set in P5-07, as follows:

- 1) Main frequency source A: The main frequency source is directly used to set the target running frequency.
- 2) Auxiliary frequency source B: The auxiliary frequency source is directly used to set the target running frequency.
- 3) A and B operation: There are four operation methods, namely, A+B, A-B, maximum of A and B, and minimum of A and B.
- 4) Frequency switchover: S terminal is used to switch over between the preceding three frequency setting channels.

The following Figure shows how to set the relationship in P5-07, in which the bold line indicates the default setting. Diagram 4-17 Relationship between the target running frequency and main and auxiliary frequency sources

The operation between the main frequency source and the auxiliary frequency source can be used for closed-loop speed control. For example, using the main frequency source for setting the required frequency and the auxiliary frequency source for automatic adjustment, in conjunction with switchover performed by the external S terminal signal, the required closed-loop control can be implemented.

#### 4.9.3 Binding Command Source to Frequency Source

The three command sources can be separately bound to frequency sources, as

shown in Figure 4-17. When the specified command source (P5-02) is bound to a frequency source (corresponding digit in the value of P5-27), the frequency is determined by the frequency setting channel set in P5-27. In this case, both main and auxiliary frequency sources are ineffective.

#### 4.9.4 AI as the Frequency Source

The AI terminal can be used as the frequency source. The CM540 provides two AI terminals (AI1 and AI2) on the control board, and the optional I/O extension card provides another AI terminal (AI3).

The following Figures show how to use the AI as the frequency source.

Figure 4-18 Voltage input of AI1 connected to the potentiometer as the frequency source (2–10 V corresponding to 10–40 Hz)

Figure 4-19 Current input of AI2 connected to 4DA module of the PLC as the frequency source (4–20 mA corresponding to 0–50 Hz)

Note:

1. CM540 provides two AI terminals (AI1 and AI2) on the control board, and the optional I/O extension card provides another AI terminal (AI3).
2. AI1 provides 0–10 V voltage input. AI2 provides 0–10 V voltage input or 4–20 mA current input, determined by jumper JP2 on the control board. AI3 provides -0 V to +10 V bipolar voltage input.
3. When V is used as the frequency source, 100% of the voltage or current input corresponding setting corresponds to the maximum frequency in P5-10.
4. CM540 provides five corresponding relationship curves, which can be selected in P4-33. The input values and corresponding settings of each curve are set in P4-13 to P4-27 and group C6.

#### 4.9.5 Pulse Setting as the Frequency Source

In many scenarios, pulse input is used as the frequency source. The specifications of pulse signals are: voltage 9–30 V, frequency 0–100 kHz. Only S5 can be used for pulse input. The relationship between pulse input from S5 and the corresponding setting is set in P4-28 to P4-31. The relationship is a two-point line, and 100% of pulse input corresponding setting corresponds to the

maximum frequency of P5-10, as shown in Figure 4-22.

#### 4.9.6 Frequency Closed-Loop Control

The CM540 has a built-in PID regulator. Together with the frequency sources, the PID regulator can implement automatic adjustment of process control, such as constant temperature, constant pressure, and tension control.

Diagram 4-21 Automatic adjustment by PID regulator

When PID frequency closed-loop control is implemented, P5-03(Main frequency source A selection) must be set to 8 (PID). The PID-related parameters are set in group HA, as shown in Figure 4-21.

The CM540 has two built-in equivalent PID calculating units. You can set the features, such as adjustment speed and accuracy, for the two units separately based on the actual conditions. Switchover between the two units can be implemented automatically or by means of an external S terminal.

#### 4.9.7 Swing Mode

In textile and chemical processing equipment, the application of swing frequency function can improve the coiling uniform flat of spindle. As diagram below: it can be achieved by setting Pb-00 to Pb-04 function code.

About the specific methods, please refer to the related function code detailed description.

#### 4.9.8 Multi-Speed Mode

In scenarios where the running frequency of the AC drive need not be adjusted continuously and only several frequencies are required, the multi-speed control can be used. The CM540 supports a maximum of 16 running frequencies, which are implemented by state combinations of four S terminals. Set the function codes corresponding to S terminals to a value among 12 to 15, and then the S terminals are specified as the multi-frequency input terminals. The multiple frequencies are set based on the multi-frequency table in group HC. In addition, you need to set P5-03 (Main frequency source A selection) to 6 (Multi reference). The following Figure shows how to set the multi-speed function.

In the preceding Figure, S8,S4,S7,S2 are used as the multi-frequency input terminals, each of which has a bit value. The state combinations of these terminals correspond to multiple frequencies, When (S8、 S4、 S7、 S2)=(0、 0、 1、 0), the state combination value is 2, corresponding to the value set in PC-02. The target running frequency is automatically calculated by (PC-02 )x( P5-10). The CM540 supports a maximum of four S terminals to be used as the multi-frequency input terminals. You can also use less than four DI terminals, and the empty bit is considered to be 0.

#### 4.9.9 Setting the Motor Rotating Direction

After the AC drive restores the default settings, press RUN to drive the motor to rotate. In this case, the rotating direction is regarded as the forward rotation. If the rotating direction is reverse to the direction required by the equipment, power off the AC drive and exchange any two of the output UVW cables (wait until the main capacitor of the AC drive is completely discharged).

In some applications where both forward rotation and reverse rotation are required, enable the reverse control (P8-13 = 0, default value) and meanwhile reverse the rotating direction by setting P5-09 to 1. Then press RUN to make the motor rotate in the reverse direction, as shown in the following Figure.

If the command source is terminal control and reverse rotation is required, use the default value 0 of P8-13 to enable reverse control.

According to the preceding Figure, when the running frequency of the AC drive is set by means of communication (P0-03 = 9) and reverse control is enabled (P8-13 = 0), the AC drive instructs the reverse direction if the set frequency  $F_s$  is a negative value. If the give running command is reverse rotation or the set frequency is a negative value, but reverse control is disabled (P8-13 = 1), the AC drive will run at 0 Hz and has no output. In some applications where reverse rotation is prohibited, do not change the rotating direction by modifying the function codes because the function codes will be restored once the AC drive restores the default settings

#### 4.9.10 Setting the Fixed Length Control Mode

The CM540 has the fixed length control function. The length pulses are sampled

by the S allocated with function 27 (Length count input). The "Actual length" (Pb-06) is obtained by dividing the number of pulses sampled by the value of Pb-07 (Number of pulses per meter). If the actual length is larger than the "Set length" (Pb-05), the multifunctional DO terminal becomes ON.

In the process of fixed length control, the length can be reset by means of the S terminal allocated with function 28 (Length reset). The related setting is shown in the following Figure.

Note:

- 1) In the fixed length control mode, the direction cannot be identified and only the length shall be calculated based on the number of pulses.
- 2) Only S5 can be allocated with the function "Length count input".
- 3) An automatic stop system can be implemented if the length reached signal output by the DO is fed back to the AC drive input terminal with the stop function

#### **4.9.11 Use of the Counting Function**

The count value needs to be collected by the S terminal that is allocated with function 25. When the count value reaches Pb-08 (Set count value), the S terminal allocated with function 8 (Set count value reached) becomes ON. Then the counter stops counting. When the count value reaches Pb-09 (Designated count value), the S terminal allocated with function 9 (Designated count value reached) becomes ON. The counter continues to count until "Set count value" is reached.

Note:

1. Pb-09 (Designated count value) must not be greater than Pb-08 (Set count value).
2. S5 must be used when the pulse frequency is high.
3. The DO terminal that is allocated with function 9 (Designated count value reached) and the DO terminal that is allocated with function 8 (Set count value reached) must not be the same.
4. In the RUN/STOP state of the AC drive, the counter will not stop until "Set

count value" is reached.

5. The count value is retentive at power failure.

6. An automatic stop system can be implemented if the signal output by the DO terminal with the function (Count value reached) is fed back to the DI terminal of the AC drive with stop function.

## 4.10 Setting and Auto-tuning of Motor Parameters

### 4.10.1 Motor Parameters to Be Set

When the AC drive runs in the vector control mode (P5-01 = 0 or 1), accurate motor parameters are required to ensure desired driver performance and running efficiency. This is extremely different from the V/F control (P5-01 = 2).

Motor parameters (motor 1 by default) that need to be set are listed in the following table.

Parameter	Description	Remrk
P1-00	Motor type	Asynchronous motor, variable frequency asynchronous motor, synchronous motor
P1-01~P1-05	Rated motor power, Rated motor voltage, Rated motor current, Rated motor frequency, Rated motor rotational speed.	Model parameters, Manual input
P1-06~P1-20	Motor internal equivalent stator resistance, inductive reactance and rotor inductance.	Auto-tuning parameters
P1-27~P1-34	Encoder parameters (these parameters need to be set in the vector control)	Encoder parameters

For complicated application system with multiple motors, the parameters of motors 2 is listed in the following table

Motor 2 Parameter	Remark
H2-00	Asynchronous motor, variable-frequency asynchronous motor, synchronous motor

H2-01~H2-05	Model parameters, manual input
H2-06~H2-20	Auto-tuning parameters
H2-27~H2-34	Encoder parameters

#### 4.10.2 Motor Auto-tuning

To obtain the motor parameters, the AC drive can perform dynamic auto-tuning or static auto-tuning. For the asynchronous motor that cannot be disconnected from the load, you can input the motor parameters of the same model that was successfully auto-tuned before.

Auto-tuning	Application	Result
No-load dynamic auto-tuning	It is applied to applications where the motor (synchronous motor or asynchronous motor) can be disconnected from the load.	Best
With-load dynamic auto-tuning	It is applied to applications where the motor (synchronous motor or asynchronous motor) cannot be disconnected from the load.	OK
Static auto-tuning	It is applied to applications where the motor (asynchronous motor only) cannot be disconnected from the load and dynamic auto-tuning is not allowed.	Poor
Manual input	It is applied to applications where the motor (asynchronous motor only) cannot be disconnected from the load. Input the motor parameters of the same model that was successfully auto tuned before into function codes P1-00 to P1-10.	OK

The following motor auto-tuning description takes motor 1 as an example. The auto-tuning of motor 2 is the same and only the function codes are changed correspondingly. The process of motor auto-tuning is as follows:

- 1) If the motor can be disconnected from the load, disconnect the motor from the load mechanically after power-off so that the motor can run without load.
- 2) After power-on, set P5-02 (Command source selection) to 0 (Operation panel control).
- 3) Input the motor nameplate parameters (such as P1-00 to P1-05) correctly and input the following parameters based on the actually selected motor.



Motor	Parameter
Motor 1	P1-00:Motor type selection P1-01:Rated motor pow P1-02:Rated motor voltage P1-03:Rated motor current P1-04:Rated motor frequency P1-05:Rated motor rotational speed
Motor 2	H2-00 to H2-05, defined the same as P1-00 to P1-05

For asynchronous motor, set P1-37 (Auto-tuning selection) to 2 (Asynchronous motor complete auto-tuning). For motors 2, 3, or 4, the corresponding function code is H2-37 Press ENTER on the operation panel. The operation panel displays:

TUNE

Then press RUN on the operation panel. The AC drive will drive the motor to accelerate/ decelerate and run in the forward/reverse direction, and the RUN indicator is ON. The auto tuning lasts approximately 2 minutes. When the preceding display information disappears and the operation panel returns to the normal parameter display status, it indicates that the auto-tuning is complete. The AC drive will automatically calculate the following motor parameters:

Motor	Parameter
Motor 1	P1-06:Stator resistance (asynchronous motor) P1-07:Rotor resistance (asynchronous motor) P1-08:Leakage inductive reactance (asynchronous motor) P1-09:Mutual inductive reactance (asynchronous motor) P1-10:No-load current (asynchronous motor)
Motor 2	H2-06 to H2-10, defined the same as P1-06 to P1-10

If the motor cannot be disconnected from the load, set P1-37 (Motor 2 is H2-37) to 1 (Asynchronous motor static tuning) and then press RUN on the operation panel. The motor auto-tuning starts.

In the synchronous motor system driven by CM540, and encoder for signal

feedback is required. Therefore, you need to set the encoder parameters correctly before the auto-tuning. During the synchronous motor auto-tuning, the synchronous motor must rotate, and the best auto-tuning mode is no-load dynamic auto-tuning. If it is not allowed, you can perform with-load dynamic auto-tuning.

### 4.10.3 Setting and Switchover of Multiple Groups of Motor Parameters

The AC drive supports switchover between two groups of motor parameters, namely, groups H1,H2 (motor 1 parameters and encoder parameters).

You can select the current effective motor parameter group by means of function code P5-24 or DI terminals with functions 41. When the DI terminals with functions 41 become ON, they are privileged and the setting of P5-24 becomes invalid.

### 4.11 Use of S Terminals

The control board provides five S terminals S1 to S5. You can obtain another S terminals S6 to S8 by installing an I/O extension card.

The internal hardware of S terminals are configured with 24 VDC power supply for detection. You can input a signal to a S terminal of the AC drive only by shorting the S terminal and COM.

By default, P4-38 = 0000 and P4-39 = 0000. When a DI terminal is shorted to COM, it is active (logic 1). When a SDI terminal is not shorted to COM, it is inactive (logic 0). You can change the DI terminal active mode. That is, a DI terminal is inactive (logic 0) when being shorted with COM, and active (logic 1) when being not shorted to COM. In this case, it is necessary to change the corresponding bit in P4-38 and P4-39 (these two parameters respectively specifying the active mode setting of DI to DI6 and S6 to S8) to 1.

The AC drive also provides P4-10 (DI filter time) for the DI signal to improve the anti-interference level. For S1 to S3, the AC drive provides the DI signal delay function, convenient for some applications requiring delay.

The preceding 8 S terminals can be defined in function codes P4-00 to P4-07.

Each S can be allocated with their respective function from the 50 functions. For details, see descriptions of P4-00 to P4-09. The hardware design allows only DI6 to receive high-speed pulse signal. If high-speed pulse count is required, use DI6.

#### 4.12 Use of DO Terminals

The control board provides two DO terminals, namely SP1、TA-TB-TC. SP1 is transistor outputs and can drive 24 VDC low-voltage circuit; TA-TB-TC is relay output, and can drive 250 VAC control circuit.

You can define the function of the DO terminals by setting P5-01 and P5-05 to indicate the running state and alarm information of the AC drive. There are a total of 40 functions. For details, see the descriptions of group H5.

Terminal	Corresponding Function Code	Output Feature Description
SP1-CME	P5-00=0,high pulse input,P5-06 selection	Transistor, able to output high-speed pulses 10 Hz to 100 kHz; drive capacity: 24V DC, 50 mA
	P5-00=1,open collector output,P5-01 selection	Transistor; drive capacity: 24 VDC, 50 mA
TA-TB-TC	P5-02	Relay1; drive capacity: 250 VAC, 3 A
TA2-TB2-T C2	P5-03	Extension card, relay 2; drive capacity: 250V AC,
SP2-CME	P5-04	Transistor; drive capacity: 24 VDC, 50 mA
TA3-TB3-T C3	P5-05	Extension card, relay 3; drive capacity: 250V AC , 3A

When P5-00 = 0, the S terminal is high-speed pulse output. The frequency of output pulses indicates the value of the internal running parameters. The greater the value is, the higher the output pulse frequency is. The 100% value corresponds to 100 kHz. The property of the indicated internal parameter is defined by P5-06.

#### 4.13 V Use of Input Signal Terminals

The AC drive supports a total of three V source, among which AI1 and AI2 are provided on the control board and AI3 is provided on the extension card.

Terminal	Input Signal Characteristic
AI1-GND	It receives the signal of 0–10 VDC.
AI2-GND	If JP2 is connected to the position with "V" mark, it receives the signal of 0–10V DC. If JP2 is connected to the position with "mA" mark, it receives the signal of 4–20 mA.
AI3-GND	It is provided on the extension card and receives the signal of 0 to +10V DC.

As external voltage/current signal, AI is used for frequency source setting, torque setting, voltage setting at V/F separation, and PID setting or feedback. The corresponding relationship of the voltage or current and actual setting or feedback is defined by P4-13 to P4-27.

Diagram 4-29 Defining corresponding relationship of the voltage or current and actual setting or feedback

The sampling of V terminals can be queried in U0-09 to U0-11. The calculation value is for internal subsequent calculation and cannot be directly read by the user.

#### 4.14 Use of FM Terminals

The AC drive supports a total of two FM terminals, among which A01 is provided by the control board and A02 is provided on the extension card.

Terminal	Output Signal Characteristic
AO1-GND	If JP9 is connected to the position with "V" mark, it outputs the signal of 0–10V DC.
	If JP9 is connected to the position with "mA" mark, it outputs the signal of 0–20 mA.
AO2-GND	If JP19 is connected to the position with "V" mark, it outputs the signal of 0~10V Dc.

If JP19 is connected to the position with "mA" mark, it outputs the signal of 0–20 mA.

AO1 and AO2 can be used to indicate the internal running parameters in the analog mode.

The property of indicated parameters can be defined by P5-07 and P5-08. The designated running parameters can be rectified before output. The rectification feature is  $Y = kX + b$ , among which "X" indicates the running parameters to be output, and "k" and "b" of AO1 can be set by P5-10 and P5-11

#### 4.15 Use of the PG Terminal

The closed-loop vector control with sensor (P5-01 = 1) helps to improve the speed stability accuracy of the AC drive. In this case, it is necessary to install an encoder for the motor. Signals from the encoder are fed back to the AC drive through the PG card. The CM540 provides PG cards of two different types of signal features.

The AC drive supports two types of encoders, differential encoder, open-collector encoder. The setting of encoder parameters varies with the actually used encoder type. Here takes motor 1 parameters as an example for description.

- For the differential encoder, set P1-27 (Encoder pulses per revolution) and set P1-28 to 0 (ABZ incremental encoder).
- For the open-collector encoder, set P1-27 (Encoder pulses per revolution) and set P1-28 to 0 (ABZ incremental encoder).

#### 4.16 Use of Serial Communication

When communication mode CAN-LINK open are adopted, you need to install a corresponding extension card (EXT2-IO) on the CM540 series AC drive, and set P5-28 correctly according to the used communication protocol type. CAN-link is enabled by default and you need not select it.

For the configuration of hardware communication parameters for the communication port, see group Hd. Set the communication rate and data format to consistent with those of the host computer, which is the precondition of normal

communication.

The CM540 serial port itself supports the Modbus RTU slave communication protocol. You can query or modify the AC drive's function codes, query various running state parameters, and send running command and running frequency to the AC drive from the host computer through the serial port.

The CM540 arranges the function codes, running state parameters and running commands in the "register parameter address" mode. The host computer can define the protocol of communication data interaction.

#### **4.18 Password Setting**

The AC drive provides the user password protection function. When PP-00 is set to a nonzero value, the value is the user password. The password takes effect after you exit the function code editing state. When you press MODE again, "-----" will be displayed, and you must enter the correct user password to enter the menu.

To cancel the password protection function, enter with password and set PP-00 to 0.

#### **4.19 Parameter Saving and Default Setting Restoring**

After a function code is modified on the operation panel, the modification will be saved in the register of the AC drive and remain effective at next power-on.

The AC drive supports backup and restoration of parameter setting, which is convenient for commissioning.

The AC drive also provides the retentive function on alarm information and accumulative running time.

You can restore the backup values or default settings of the function codes of the AC drive or clear the running data through PP-01. For details, see the description of PP-01

## Chapter5 Function Code Table

If HP - 00 is set to non-zero number, parameter protection is enabled. Under the situation of function parameter model and user change parameter model, you must enter the correct password to enter the parameter menu. If you want to cancel, please PP-00 is set to 0.

Customized parameters mode menu is not protected by password.

Group H and Group C are standard function parameter, Group D are monitoring function parameters. The symbols in the function code table are described as follows:

“√”:The parameter settings can be modified when the VFD is either stop or running state;

“×”:The parameters settings can not be modified when the VFD is in the running state;

“○”:Parameter value is the actual testing records, it can not be modified;

Standard function parameter table:

Function Code	Parameter Name	Setting Range	Factory Default	Property
P0 Standard Function Group				
P0-00	GP Type selection	1:G Type ( Constant torque load ) 2:P Type ( variable torque load e.g. Fan and water pump load models )	1	×

P0-01	Motor 1 control mode	0:Speed sensor-less vector control ( SVC ) 1:speed sensor vector control ( FVC ) 2:V/Fcontrol	0	×
P0-02	Command source selection	0:Operation panel command channel ( LED off ) 1:Terminal command channel ( LED on ) 2:Communication command channel ( LED blinking )	0	√
P0-03	Main frequency source A selection	0:Digital setting ( preset frequency P5-08 , UP/DOWN can be modified , non-retentive at power failure ) 1:Digital setting ( preset frequency P5-08 , UP/DOWN can be modified , retentive at power failure ) 2:A11 3:A12 4:A13 5:HDI pulse setting ( S5 ) 6:Multi-reference 7:Simple PLC 8:PID 9:communication setting	0	×
P0-04	Auxiliary frequency source B selection	The same with P5-03 ( Main frequency source A selection )	0	×
P0-05	Superimposed auxiliary frequency source B	0:Relative to maximum frequency 1:Relative to the frequency	0	√



Function Code	Parameter Name	Setting Range	Factory Default	Property
P0-06	Superimposed auxiliary frequency source B range	0%~150%	100%	√
P0-07	Frequency source superposition selection	Unit's digit: frequency source selection 0:main frequency source A 1:The operation result of A and B ( operation relationship Determined by ten's digit ) 2:Switchover between A and B 3:Switchover between A and "A and B operation" 4:The switchover between uxiliary frequency source B and the operation result of A and B Ten's digit: A and B operation relationship) 0:A+B ; 1:A-B ; 2:Max(A,B) 3:Min(A,B)	00	√
P0-08	preset frequency	0.00Hz~maximum frequency ( P5-10 )	50.00Hz	√
P0-09	Rotation direction	0:Rotation direction 1:Reverse direction	0	√
P0-10	Maximum frequency	50.00Hz~320.00Hz	50.00Hz	×
P0-11	Source of frequency upper limit	0:Set by P5-12 1:A11 ; 2:A12 ; 3:A13 4:HDI Pulse setting 5:Communication setting	0	×
P0-12	Frequency upper limit	Frequency lower limit P5-14~maximum frequency P5-10	50.00Hz	√
P0-13	Frequency upper	0.00Hz~maximum frequency	0.00Hz	√

	limit offset	P5-10		
P0-14	Frequency lower limit	0.00Hz~P5-12 (Frequency lower limit)	0.00Hz	√
P0-15	Carrier frequency	0.5kHz~16.0kHz	Model dependent	√
P0-16	Carrier frequency adjustment With temperature	0:No 1:Yes	1	√
P0-17	Acceleration time 1	0.00s~65000s	Model dependent	√
P0-18	Deceleration time 1	0.00s~65000s	Model dependent	√
P0-19	Acceleration/ Deceleration time unit	0:1s ; 1:0.1s ; 2:0.01s	1	×
P0-21	Frequency offset of auxiliary frequency source for X and Y operation	0.00Hz~P5-10(maximum frequency)	0.00Hz	√
Function Code	Parameter Name	Setting Range	Factory Default	Property
P0-22	Frequency reference resolution	1:0.1Hz 2:0.01Hz	2	×
P0-23	Retentive of digital setting frequency upon power failure	0:Not retentive 1:Retentive	0	√
P0-24	Motor selection	0:motor 1    1:motor2	0	×
P0-25	Acceleration/ Deceleration time base frequency	0:Maximum frequency(P5-10) 1:Set frequency 2:100Hz	0	×

P0-26	Base frequency for UP/ DOWN modification during running	0:Running frequency 1:Set frequency	0	×
P0-27	Binding command source to frequency source	Unit's digit: (Binding operation panel command to frequency source) 0:No binding 1:Digital set frequency 2:A11 3:A12 4:A13 5:HDI Pulse setting ( S5 ) 6:multi-speed 7:Simple PLC 8:PID 9: Communication setting Ten's digit: Terminal command binding frequency source Hundred's digit: Binding communication command to frequency source) Thousand's digit: automatic operation binding frequency source	0000	√
P0-28	Serial communication protocol	0:Modbus protocol	0	√
P1 Motor 1 Parameters				
P1-00	Motor type selection	0:Common asynchronous motor 1:Variable frequency asynchronous motor 2:Permanent magnetic synchronous motor	0	×
P1-01	Rated motor power	0.1kW~1000.0kW	Model dependent	×
P1-02	Rated motor power	1V~2000V	Model dependent	×

P1-03	Rated motor current	0.01A~655.35A ( AC drive power <=55kW ) 0.1A~6553.5A ( AC drive power >55kW )	Model dependent	×
P1-04	Rated motor frequency	0.01Hz~maximum frequency	Model dependent	×
P1-05	Rated motor rotational speed	1rpm~65535rpm	Model dependent	×
P1-06	Stator resistance (asynchronous motor)	0.001Ω~65.535Ω ( AC drive power <=55kW ) 0.0001Ω~6.5535Ω	Tuning parameters	×
P1-07	Rotor resistance (asynchronous motor)	0.001Ω~65.535Ω ( AC drive power <=55kW ) 0.0001Ω~6.5535Ω	Tuning parameters	×
P1-08	Leakage inductive reactance(asynchronous motor)	0.01mH~655.35mH ( AC drive power <=55kW ) 0.001mH~65.535mH	Tuning parameters	×
P1-09	Mutual inductive reactance(asynchronous motor)	0.1mH~6553.5mH ( AC drive power <=55kW ) 0.01mH~655.35mH	Tuning parameters	×
P1-10	No-load current (asynchronous motor)	0.01A~P1-03 ( AC drive power <=55kW )	Tuning parameters	×
P1-16	Stator resistance (synchronous motor)	0.001Ω~65.535Ω ( AC drive power <=55kW ) 0.0001Ω~6.5535Ω	Tuning parameters	×
P1-17	Shaft D inductance (synchronous motor)	0.01mH~655.35mH ( AC drive power <=55kW ) 0.001mH~65.535mH	Tuning parameters	×
P1-18	Shaft Q inductance (synchronous motor)	0.01mH~655.35mH ( AC drive power <=55kW ) 0.001mH~65.535mH	Tuning parameters	×
P1-20	Back EMF (synchronous motor)	0.1V~6553.5V	Tuning parameters	×

P1-27	Encoder pulses per revolution	1~65535	1024	×
P1-28	Encoder type	0:ABZ incremental encoder 1:reserve 2:reserve 3:reserve 4:reserve	0	×
P1-30	A/B phase sequence of ABZ incremental encoder 0: Forward 1: Reserv	0:Forward 1:reverse	0	×
P1-31	Encoder installation angle	0.0°~359.9°	0.0°	×
P1-32	Reserve			
P1-33	Reserve			
P1-34	Reserve			
P1-36	Encoder wire-break fault detection time	0.0:No reply 0.1s~10.0s	0.0	×
P1-37	Auto-tuning selection	0:No auto-tuning 1:Asynchronous motor static auto-tuning 2:Asynchronous motor complete auto-tuning 11:Synchronous motor with-load auto-tuning 12:Synchronous motor no-load auto-tuning	0	×
<b>P2 Group Motor1 Vector Control Parameters</b>				
P2-00	Speed loop proportional gain 1	1~100	30	√
P2-01	Speed loop integral time1	0.01s~10.00s	0.50s	√
P2-02	Switchover frequency1	0.00~P2-05	5.00Hz	√

P2-03	Speed loop proportional gain 2	1~100	20	√
P2-04	Speed loop integral time2	0.01s~10.00s	1.00s	√
P2-05	Switchover frequency2	P2-02~maximum frequency	10.00Hz	√
P2-06	Vector control slip gain	50%~200%	100%	√
P2-07	Time constant of speed loop filter	0.000s~0.100s	0.000s	√
P2-08	Vector control Over-excitation gain	0~200	64	√
P2-09	Torque upper limit source in speed control mode	0:function code P2-10 setting 1:A11 2:A12 3:A13 4:HDI Pulse setting 5:Communication setting 6:MIN ( A11,A12 ) 7:MAX ( A11,A12 ) Full range of options1-7 corresponding to P2-10	0	√
P2-10	Digital setting of torque upper limit in speed control mode	0.0%~200.0%	150.0%	√
P2-13	Excitation adjustment proportional gain	0~60000	2000	√
P2-14	Excitation adjustment integral gain	0~60000	1300	√
P2-15	Torque adjustment proportional gain	0~60000	2000	√

P2-16	Torque adjustment Integral gain	0~60000	1300	√
P2-17	Speed loop integral property	Unit's digit:integral separation 0:Disabled 1:Enabled	0	√
P2-18	Field weakening mode of synchronous motor	0:Field weakening mode invalid 1:Field weakening mode 2:Automatic adjustment	1	√
P2-19	Field weakening depth of synchronous motor	50%~500%	100%	√
P2-20	Field weakening depth of synchronous motor	1%~300%	50%	√
P2-21	Field weakening automatic adjustment gain	10%~500%	100%	√
P2-22	Field weakening integralmultiple	2~10	2	√
P3 Group V/F Control parameter				
P3-00	V/F curve setting	0:Linear V/F 1:Multi-point V/F 2:Square V/F 3:1.2 -power V/F 4:1.4 -power V/F 6:1.6 -power V/F 8:1.8 -power V/F 9:Reserved 10:VF complete separation 11:VF half separation	0	×
P3-01	Torque boost	0.0%: ( Automatic torque boost ) 0.1%~30.0%	Model dependent	√
P3-02	Cut-off frequency of torque boost	0.00Hz~maximum frequency	50.00Hz	×
P3-03	Multi-point V/F frequency 1	0.00Hz~P3-05	0.00Hz	×

P3-04	Multi-point V/F voltage 1	0.0%~100.0%	0.0%	×
P3-05	Multi-point V/F frequency 2	P3-03~P3-07	0.00Hz	×
P3-06	Multi-point V/F voltage 2	0.0%~100.0%	0.0%	×
P3-07	Multi-point V/F frequency 3	P3-05~rated motor frequency ( P1-04 )	0.00Hz	×
P3-08	Multi-point V/F voltage 3	0.0%~100.0%	0.0%	×
P3-09	V/F slip compensation gain	0.0%~200.0%	0.0%	√
P3-10	V/F over-excitation gain	0~200	64	√
P3-11	V/F oscillation suppression gain	0~100	Model dependent	√
P3-13	V/F oscillation suppression gain	0:Digital setting ( P3-14 ) 1:A11 2:A12 3:A13 4:HDI Pulse setting ( S5 ) 5:Multi-reference 6:Simple PLC 7:PID 8:Communication setting Note :100.0% corresponds to the rated motor voltage	0	√
P3-14	Voltage digital setting for V/F separation	0V~rated motor voltage	0V	√
P3-15	Voltage rise time of V/F separation	0.0s~1000.0s Note: It indicates the time for the voltage rising from 0 V to rated motor voltage.	0.0s	√



P4 Group Input Terminals				
P4-00	DI1 Terminal function selection	0:No function	1	×
P4-01	DI2 Terminal function selection	1:Forward RUN ( FWD )	4	×
P4-02	DI3 Terminal function selection	2:Reverse RUN ( REV )	9	×
P4-03	DI4 Terminal function selection	( When setting to 1, 2, it needs to be used with P4-11 )	12	×
P4-04	DI5 Terminal function selection	3:Three-line running control	13	×
P4-05	DI6 Terminal function selection	4:Forward JOG ( FJOG )	0	×
P4-06	Reserved	5:Reverse JOG ( RJOG )	0	×
P4-07	Reserved	6:Terminal UP	0	×
P4-08	Reserved	7:Terminal DOWN	0	×
		8:Coast to stop	0	×
		9:Fault reset ( RESET )	0	×

P4-09	Reserved		0	×
-------	----------	--	---	---

Function Code	Parameter Name	Setting Range	Default	Property
P4-10	S input terminal filter time	0.000s~1.000s	0.010s	√
P4-11	Terminal command mode	0:Two-line mode 1 1:Two-line mode 2 2:Three-line mode 1 3:Three-line mode 2	0	×
P4-12	terminal UP/DOWN change rate	0.001Hz/s~65.535Hz/s	1.00Hz/s	√

P4-13	V curve 1 minimum input	0.00V~P4-15	0.00V	√
P4-14	Corresponding setting of V Curve 1 minimum input	-100.0%~+100.0%	0.0%	√
P4-15	V curve 1 maximum input	P4-13~+10.00V	10.00V	√
P4-16	Corresponding setting of V Curve 1 maximum input	-100.0%~+100.0%	100.0%	√
P4-17	AI1 filter time	0.00s~10.00s	0.10s	√
P4-18	V curve 2 minimum input	0.00V~P4-20	0.00V	√
P4-19	Corresponding setting of V Curve 2 minimum input	-100.0%~+100.0%	0.0%	√
P4-20	V curve 2 maximum input	P4-18~+10.00V	10.00V	√
P4-21	Corresponding setting of Curve 1 maximum input	-100.0%~+100.0%	100.0%	√
P4-22	AI2 filter time	0.00s~10.00s	0.10s	√
P4-23	V Curve 3 minimum input	-10.00V~P4-25	-10.00V	√
P4-24	Corresponding setting of V Curve 3 minimum input	-100.0%~+100.0%	-100.0%	√
P4-25	V Curve 3 maximum input	P4-23~+10.00V	10.00V	√
P4-26	Corresponding setting of V Curve 3 maximum input	-100.0%~+100.0%	100.0%	√
P4-27	AI3 filter time	0.00s~10.00s	0.10s	√
P4-28	HDI minimum input	0.00kHz~P4-30	0.00kHz	√

P4-29	Corresponding setting of HDI minimum input	-100.0%~100.0%	0.0%	√
P4-30	HDI maximum input	P4-28~100.00kHz	50.00kHz	√
P4-31	HDI maximum input setting	-100.0%~100.0%	100.0%	√
P4-32	HDI filter time	0.00s~10.00s	0.10s	√
P4-33	V Analog input curve selection	Unit's digit:A11 curve selection 1:curve 1 ( 2 points , see P4-13~P4-16 ) 2:curve 2 ( 2 points , see P4-18~P4-21 ) 3:curve 3 ( 2 points , see P4-23~P4-26 ) 4:curve 4 ( 4 points , see H6-00~H6-07 ) 5:curve 5 ( 4 points , see H6-08~H6-15 ) Ten's digit:A12 curve selection Curve 1 to curve 5 (same as A11) Hundred's digit: A13 curve selection , Curve 1 to curve 5 (same as A11)	321	√
P4-34	Setting for V less than minimum input	Unit's digit:A11 set below the minimum input selection 0:Corresponding to the minimum input set 1:0.0% Ten's digit:A12 set below the minimum input selection , the same as above Hundred's digit:A13 set below the minimum input selection , the same as above	000	√
P4-35	S1 delay time	0.0s~3600.0s	0.0s	×

P4-36	S2 delay time	0.0s~3600.0s	0.0s	×
-------	---------------	--------------	------	---

Function Code	Parameter Name	Setting Range	Default	Property
P4-37	S3 delay time	0.0s~3600.0s	0.0s	×
P4-38	S input terminal valid mode selection 1	0:Positive logic 1:Negative logic Unit's digit:S1 Ten's digit:S2 Hundred's digit:S3 Thousand's digit:S4 Ten thousand's digit:S5	00000	×
P4-39	S input terminal valid mode selection 2	0:Positive logic 1:Negative logic Unit's digit:S6 Ten's digit:S7 Hundred's digit:S8 Thousand's digit: reserved Ten thousand's digit: reserved	00000	×
P5 Group output terminal				
P5-00	SP1 terminal output mode selection	0:pulse output ( HDO ) 1:Open collector output ( SP1 )	0	√
P5-01	Control board SP1open collector output function selection	0:No output 1:AC drive running 2:Fault output ( downtime ) 3:Frequency-level detection FDT1 output 4:Frequency reached 5:Zero-speed running ( no output at stop) 6:Motor overload pre-warning 7:AC drive overload pre-warning 8:Set count value reached 9:Designated count value reached 10:Length reached 11:PLC cycle complete	0	√

P5-02	Control board relays 1 function selection ( TA-TB-TC )		2	√
P5-03	Extension card relay 2 output function selection		0	√
P5-04	Reserved		1	√
P5-05	Reserved		4	√

Function Code	Parameter Name	Setting Range	Default	Property
---------------	----------------	---------------	---------	----------

P5-06	HDO High-speed pulse output function selection	0:Running frequency 1:Set frequency 2:Output current 3:Output torque ( absolute	0	√
P5-07	A01 Analog output function selection	value ) 4:Output power 5:Output voltage 6:HDI High-speed pulse input ( S5 terminal , 100.% corresponding to 100.0kHz )	0	√
P5-08	Extension card A02 analog output function selection	7:A11 8:A12 9:A13 ( Extension card ) 10:Extension card 11:Count value 12:Communication setting 13:Motor rotational speed 14:Output current ( 100.0% corresponding to 1000.0A ) 15:corresponding to ( 100.0% corresponding to 1000.0V ) 16:Output torque (actual value)	1	√
P5-09	HDO Output the maximum frequency	0.01kHz~100.00kHz	50.00kHz	√
P5-10	A01 offset coefficient	-100.0%~+100.0%	0.0%	√
P5-11	A01 gain	-10.00~+10.00	1.00	√
P5-12	Extension card A02 offset coefficient	-100.0%~+100.0%	0.0%	√
P5-13	Extension card A02 gain	-10.00~+10.00	1.00	√

P5-17	SP1 open collector output delay time	0.0s~3600.0s	0.0s	√
P5-18	Control board relay 1 TA-TB-TC output delay time	0.0s~3600.0s	0.0s	√
P5-19	Extension card relay2 TA2-TB2-TC2 output delay time	0.0s~3600.0s	0.0s	√
P5-20	Extension card SP2 output delay time	0.0s~3600.0s	0.0s	√
P5-21	Extension card relay 3 TA3-TB3-TC3 output delay time	0.0s~3600.0s	0.0s	√
P5-22	DO output terminal valid state selection	0:Positive logic 1:Negative logic Unit's digit:SP1 Ten's digit: TA-TB-TC Hundred's digit:TA2-TB2-TC2 Thousand's digit:SP2 Ten thousand's digit:TA3-TB3-TC3	00000	√
Group P6 Start/Stop Control				
Function Code	Parameter Name	Setting Range	Defaults	Property
P6-00	start mode	0:Direct start 1:Rotational speed tracking restart 2:Pre-excited start ( asynchronous motor )	0	√
P6-01	Rotational speed Tracking mode	0:From frequency at stop 1:From zero speed 2:From maximum frequency	0	×
P6-02	Rotational speed Tracking speed	1~100	20	√



P6-03	Startup frequency	0.00Hz~10.00Hz	0.00Hz	√
P6-04	Startup frequency Holding time	0.0s~100.0s	0.0s	×
P6-05	Startup DC braking current/Pre-excited current	0%~100%	0%	×
P6-06	Startup DC braking time/ Pre-excited time	0.0s~100.0s	0.0s	×
P6-07	Acceleration/ Deceleration mode	0:Linear acceleration/ deceleration 1:S-curve acceleration/ deceleration A 2 S-curve acceleration/ deceleration B	0	×
P6-08	Time proportion of S-curve start segment	0.0%~ ( 100.0%-P6-09 )	30.0%	×
P6-09	Time proportion of S-curve end segment	0.0%~ ( 100.0%-P6-08 )	30.0%	×
P6-10	Stop mode	0:Decelerate to stop 1:Coast to stop	0	√
P6-11	Initial frequency of stop DC braking	0.00Hz~maximum frequency	0.00Hz	√
P6-12	Waiting time of stop DC braking	0.0s~100.0s	0.0s	√
P6-13	Stop DC braking current	0%~100%	0%	√
P6-14	Stop DC braking time	0.0s~100.0s	0.0s	√
P6-15	Stop DC braking time	0%~100%	100%	√
Group P7 Operation Panel and Display				
P7-01	MF.K Key function selection	0:MF.K key disabled 1 Switchover between operation panel control and remote command control (terminal or communication) 2:Switchover between forward rotation and reverse rotation 3:Forward JOG 4:Reverse JOG	0	×

P7-02	STOP/RESET key function	0:STOP/RESET key enabled only in operation panel control 1:STOP/RESET key enabled in any operation mode	1	√
P7-03	LED display running parameters 1	0000~FFFF Bit00:Running frequency 1( Hz ) Bit01:Set frequency ( Hz ) Bit02:Bus voltage ( V ) Bit03:Output voltage ( V ) Bit04:Output current ( A ) Bit05:Output power ( kW ) Bit06:Output torque ( % ) Bit07:S input terminal state Bit08:DO output terminal state Bit09:AI1 voltage ( V ) Bit10:AI2 voltage ( V ) Bit11:AI3 voltage ( V ) Bit12:Count value Bit13:Length value Bit14:Load speed display Bit15:PID setting	1F	√
P7-04	LED running display parameters2	0000~FFFF Bit00:PID feedback Bit01:PLC Stage Bit02:HDI input(S5 terminal) pulse frequency ( kHz ) Bit03:Running frequency 2(Hz) Bit04:Remaining running time Bit05:AI1 voltage before correction ( V ) Bit06:AI2 voltage before correction ( V ) Bit07:AI3 voltage before correction ( V ) Bit08:Linear speed	0	√

		Bit09:Current power-on time ( Hour ) Bit10:Current running time ( Min ) Bit11:HDI input pulse frequency ( Hz ) Bit12:Communication setting value Bit13:Encoder feedback speed ( Hz ) Bit14:Main frequency A display ( Hz ) Bit15:Auxiliary frequency B display		
P7-05	LED drive stop parameter display	0000~FFFF Bit00:Set frequency ( Hz ) Bit01:Bus voltage ( V ) Bit02:S terminal input status Bit03:DO terminal output status Bit04:AI1voltage ( V ) Bit05:AI2 voltage ( V ) Bit06:AI3 voltage ( V ) Bit07:Count value Bit08:Length value Bit09:PLC stage Bit10:Load speed Bit11:PID setting Bit12:HDI input pulse frequency ( kHz )	33	√
P7-06	Load speed display coefficient	0.0001~6.5000	1.0000	√
P7-07	Heatsink temperature of inverter module	0.0°C~100.0°C	-	○
P7-08	Reserved		-	○
P7-09	Accumulative running	0h~65535h	-	○

	time			
P7-10	Product number	-	-	○
P7-11	Software version	-	-	○
P7-12	Number of decimal places for load speed display	0:0 decimal place 1:1 decimal place 2:2 decimal place 3:3 decimal place	1	√
P7-13	Accumulative power-on time	0h~65535 h	-	○
P7-14	Accumulative power consumption	0kW~65535 kWh	-	○
Group P8 Auxiliary Functions				
P8-00	JOG running frequency	0.00Hz~maximum frequency	2.00Hz	√
P8-01	JOG acceleration time	0.0s~6500.0s	20.0s	√
P8-02	JOG deceleration time	0.0s~6500.0s	20.0s	√
P8-03	Acceleration time 2	0.0s~6500.0s	Model dependent	√
P8-04	Deceleration time 2	0.0s~6500.0s	Model dependent	√
P8-05	Acceleration time 3	0.0s~6500.0s	Model dependent	√
P8-06	Deceleration time 3	0.0s~6500.0s	Model dependent	√
Function Mode	Parameter Name	Setting Range	Default	Property
P8-07	Acceleration time 4	0.0s~6500.0s	Model dependent	√
P8-08	Deceleration time 4	0.0s~6500.0s	Model dependent	√
P8-09	Jump frequency 1	0.00Hz~maximum frequency	0.00Hz	√
P8-10	Jump frequency 2	0.00Hz~maximum frequency	0.00Hz	√

P8-11	Frequency jump amplitude	0.00Hz~maximum frequency	0.01Hz	√
P8-12	Forward/Reverse rotation dead-zone time	0.0s~3000.0s	0.0s	√
P8-13	Reverse control prohibition	0:Enabled 1:Disabled	0	√
P8-14	Running mode when set frequency lower than frequency lower limit	0:Run at frequency lower limit 1:Stop 2:Run at zero speed	0	√
P8-15	Droop control	0.00Hz~10.00Hz	0.00Hz	√
P8-16	Accumulative power-on time threshold	0h~65000h	0h	√
P8-17	Accumulative running time threshold	0h~65000h	0h	√
P8-18	Startup protection selection	0:No 1:Yes	0	√
P8-19	Frequency detection value ( FDT1 )	0.00Hz~maximum frequency	50.00Hz	√
P8-20	Frequency detection hysteresis value ( FDT1 )	0.0%~100.0% ( FDT1 level )	5.0%	√
P8-21	Detection range of Frequency reached	0.0%~100.0% ( maximum frequency )	0.0%	√
P8-22	Jump frequency during acceleration/deceleration	0:invalid 1:valid	0	√
P8-25	Frequency switchover Point between acceleration time 1 and acceleration time 2	0.00Hz~maximum frequency	0.00Hz	√
P8-26	Frequency switchover Point between deceleration time 1	0.00Hz~maximum frequency	0.00Hz	√

	and deceleration time 2			
P8-27	Terminal JOG preferred	0:invalid 1:valid	0	√
P8-28	Frequency detection value ( FDT2 )	0.00Hz~maximum frequency	50.00Hz	√
P8-29	Frequency detection hysteresis value ( FDT2 )	0.0%~100.0% ( FDT2 level )	5.0%	√
P8-30	Any frequency reaching detection value 1	0.00Hz~maximum frequency	50.00Hz	√
P8-31	Any frequency reaching detection amplitude1	0.0%~100.0% (maximum frequency )	0.0%	√
P8-32	Any frequency reaching detection value 2	0.00Hz~maximum frequency	50.00Hz	√
P8-33	Any frequency reaching detection amplitude 2	0.0%~100.0% (maximum frequency )	0.0%	√
P8-34	Zero current detection level	0.0%~300.0% 100.0% Corresponding to the motor rated current	5.0%	√
P8-35	Zero current detection delay time	0.01s~600.00s	0.10s	√
P8-36	Output over current threshold	0.0% ( no detection ) 0.1%~300.0% ( rated motor current )	200.0%	√
P8-37	Output over current detection delay time	0.00s~600.00s	0.00s	√
P8-38	Any current reaching 1	0.0%~300.0% ( rated motor current )	100.0%	√

P8-39	Any current reaching 1 amplitude	0.0%~300.0% ( rated motor current )	0.0%	√
P8-40	Any current reaching 2	0.0%~300.0% ( rated motor current )	100.0%	√
P8-41	Any current reaching 2 amplitude	0.0%~300.0% ( rated motor current )	0.0%	√
P8-42	Timing function	0:invalid 1:valid	0	√
P8-43	Timing running time selection	0:P8-44 setting 1:A11 2:A12 3:A13 (100% of analog input corresponds to the value of F8-44)	0	√
P8-44	Timing duration	0.0Min~6500.0Min	0.0Min	√
P8-45	A11 input voltage protection value lower limit	0.00V~P8-46	3.10V	√
P8-46	A11 input voltage protection value upper limit	P8-45~10.00V	6.80V	√
P8-47	Module temperature threshold	0°C~100°C	75°C	√
P8-48	Cooling fan control	0: Fan rotating during drive running 1.Fan keeping running	0	√
P8-49	Wakeup frequency	Dormant frequency ( P8-51 ) ~maximum frequency ( P5-10 )	0.00Hz	√
P8-50	Wakeup delay time	0.0s~6500.0s	0.0s	√
P8-51	Dormant frequency	0.00Hz~wakeup frequency ( P8-49 )	0.00Hz	√
P8-52	Dormant delay time	0.0s~6500.0s	0.0s	√

P8-53	Current running reaching time setting	0.0Min~6500.0Min	0.0Min	√
Group P9 Fault and Protection				
P9-00	Motor overload protection selection	0:Disabled 1:Enabled	1	√
P9-01	Motor overload Protection gain	0.20~10.00	1.00	√
P9-02	Motor overload warning coefficient	50%~100%	80%	√
P9-03	Overvoltage stall gain	0~100	0	√
P9-04	Overvoltage stall Protective voltage	120%~150%	130%	√
P9-05	Over current stall gain	0~100	20	√
P9-06	Over current stall Protective current	100%~200%	180%	√
P9-07	Short-circuit to ground upon power-on protection function	0:invalid 1:valid	1	√
P9-09	Fault auto reset times	0~20	0	√
P9-10	during fault auto reset, fault DO action output terminal selection	0:No act 1:Act	0	√
P9-11	Time interval of fault auto reset	0.1s~100.0s	1.0s	√
P9-12	Input phase loss protection/contactor energizing protection selection	0:Disabled 1:Enabled	11	√



P9-13	Output phase loss protection selection	0:Disabled 1:Enabled	1	√
P9-14	1st fault type	0:No fault 1:Reserved 2:Overcurrent during acceleration 3:Overcurrent during deceleration 4:Overcurrent at constant speed 5: Overvoltage during acceleration	-	○
P9-15	2nd fault type	6:Overvoltage during deceleration	-	○
P9-16	3rd (latest) fault type	7:Overvoltage at constant speed 8:Buffer resistance overload 9:Undervoltage 10:AC drive overload 11:Motor overload 12:Power input phase loss 13:Power output phase loss 14:Module overheat 15:External equipment fault 16:Communication fault 17:Contactor fault 18:Current detection fault 19:Motor auto-tuning fault 20:Encoder/PG card fault 21:parameter read-write fault 22:AC drive hardware fault 23:Short circuit to ground 24:Reserved 25:Reserved 26:Running time reached 27>User-defied fault 1 28>User-defied fault 2 29:power-on time reached 30:Load becoming 0 31:PID feedback lost during running 40:rapid current-limited overtime	-	○

P9-17	Frequency upon 3rd (latest) fault	-	-	○
P9-18	Current upon 3rd (latest) fault	-	-	○
P9-19	Bus voltage upon 3rd (latest) fault	-	-	○
P9-20	Input terminal status upon 3rd fault(latest)	-	-	○
P9-21	Output terminal status upon 3rd fault(latest)	-	-	○
P9-22	AC drive status upon 3rd (latest) fault	-	-	○
P9-23	Power-on time upon 3rd(latest) fault	-	-	○
P9-24	Running time upon 3 <sup>rd</sup> fault (latest)	-	-	○
P9-27	Frequency upon 2nd fault	-	-	○
P9-28	Current upon 2nd fault	-	-	○
P9-29	Bus voltage upon 2nd fault	-	-	○
P9-30	Input terminal status upon 2 <sup>nd</sup> fault(latest)	-	-	○
P9-31	Output terminal status upon 2nd fault(latest)	-	-	○
P9-32	AC drive status upon 2nd (latest)	-	-	○
P9-33	Power-on time upon 2nd(latest)	-	-	○
P9-34	Running time upon 2 <sup>nd</sup> fault (latest)	-	-	○

P9-37	Frequency upon 1st (latest) fault	-	-	○
P9-38	Current upon 1 <sup>st</sup> fault	-	-	○
P9-39	Bus voltage upon 1st fault	-	-	○
P9-40	Input terminal status upon 1st fault	-	-	○
P9-41	Output terminal status upon 1st fault	-	-	○
P9-42	AC drive status upon 1st fault(latest)	-	-	○
P9-43	Power-on time upon 1st (latest)	-	-	○
P9-44	Running time upon 1st fault (latest)	-	-	○
P9-47	Fault protection action selection 1	Unit's digit: Motor overload ( 11 ) 0:Coast to stop 1:Stop according to the stop mode 2:Continue to run Ten's digit: Power input phase loss ( 12 ) Hundred's digit: Power output phase loss ( 13 ) Thousand's digit: External equipment fault ( 15 ) Ten thousand's digit: Communication fault ( 16 )	00000	√

<p>P9-48</p>	<p>Fault protection action selection 2</p>	<p>Unit's digit:(Encoder/PG card fault ( 20 )                      0:Coast to stop                      Ten's digit:function code read-write fault ( 21 )                      0:Coast to stop                      1:Stop according to the stop mode                      Hundred's digit:reserved                      Thousand's digit:Motor overheat ( 25 )                      Ten thousand's digit:running time reached ( 26 )</p>	<p>00000</p>	<p>√</p>
<p>P9-49</p>	<p>Fault protection action selection 3</p>	<p>Unit's digit: User-defied fault 1 ( 27 )                      0:Coast to stop                      1:Stop according to the stop mode                      2:Continue to run                      Ten's digit: User-defied fault 2 ( 28 )                      0:Coast to stop                      1:Stop according to the stop mode                      2:Continue to run                      Hundred's digit: power-on time reached ( 29 )                      0:Coast to stop                      1:Stop according to the stop mode                      2:Continue to run                      Thousand's digit:Load becoming 0 ( 30 )                      0:Coast to stop                      1:speed reducing stop                      2:Continue to run at 7% of rated motor frequency and</p>	<p>00000</p>	<p>√</p>

		resume to the set frequency if the load recovers Ten thousand's digit: PID feedback lost during running ( 31 ) 0:Coast to stop 1:Stop according to the stop mode 2:Continue to run		
P9-50	Fault protection action selection 4	Unit's digit: Too large speed deviation ( 42 ) 0:Coast to stop 1:Stop according to the stop mode 2:Continue to run Ten's digit: Motor over-speed ( 43 ) Hundred's digit: Initial position fault ( 51 )	00000	√
P9-54	Frequency selection for continuing to run upon fault	0:Running as Current running frequency 1:Running as setting frequency 2:running as frequency upper limit 3:running as frequency lower limit 4:running as Backup frequency upon abnormality	0	√
P9-55	Backup frequency upon abnormality	0.0%~100.0% ( 100.0% Corresponding to the maximum frequency P5-10 )	100.0%	√
P9-56	Type of motor Temperature sensor	0:No temperature sensor 1:PT100	0	√
P9-57	Motor overheat Protection threshold	0°C~200°C	110°C	√

P9-58	Motor overheat warning	0°C~200°C	90°C	√
P9-59	Action selection at instantaneous power failure	0:Invalid 1:Decelerate 2:Decelerate to stop	0	√
P9-60	Action pause judging voltage at instantaneous power failure	80.0%~100.0%	90.0%	√
P9-61	Voltage recovers judging time at instantaneous power failure	0.00s~100.00s	0.50s	√
P9-62	Action judging voltage At instantaneous power failure	60.0%~100.0% ( standard bus voltage )	80.0%	√
P9-63	Protection upon load becoming 0	0:Invalid 1:valid	0	√
P9-64	Detection level of load becoming 0	0.0~100.0%	10.0%	√
P9-65	Detection time of load becoming 0	0.0~60.0s	1.0s	√
P9-67	Over-speed detection value	0.0%~50.0%(maximum frequency )	20.0%	√
P9-68	Over-speed detection time	0.0s No detection 0.1~60.0s	1.0s	√
P9-69	Detection value of too large speed deviation	0.0%~50.0% ( maximum frequency )	20.0%	√
P9-70	Detection time of too Large speed deviation	0.0s No detection 0.1s~60.0s	5.0s	√
Group PA PID function				

Function Code	Parameter Name	Setting Range	Default	Property
PA-00	PID setting source	0:PA-01 setting 1:A11 2:A12 3:A13 4:HDI pulse setting ( S5 ) 5:Communication setting 6:Multi-reference setting	0	√
PA-01	PID digital setting	0.0%~100.0%	50.0%	√
PA-02	PID feedback source	0:A11 1:A12 2:A13 3:A11-A12 4:HDI pulse setting ( S5 ) 5:Communication setting 6:A11+A12 7:MAX (  A11 ,  A12  ) 8:MIN (  A11 ,  A12  )	0	√
PA-03	PID action direction	0:Forward action 1:Reverse action	0	√
PA-04	PID setting feedback range	0~65535	1000	√
PA-05	Proportional gain Kp1	0.0~100.0	20.0	√
PA-06	Integral time Ti1	0.01s~10.00s	2.00s	√
PA-07	Derivative time Td1	0.000s~10.000s	0.000s	√
PA-08	PID Cut-off frequency of PID reverse rotation	0.00~maximum frequency	2.00Hz	√
PA-09	PID deviation limit	0.0%~100.0%	0.0%	√
PA-10	PID Differential limit	0.00%~100.00%	0.10%	√
PA-11	PID setting change time	0.00~650.00s	0.00s	√

PA-12	PID feedback filter time	0.00~60.00s	0.00s	√
PA-13	PID feedback filter time	0.00~60.00s	0.00s	√
PA-14	Reserved	-	-	√
PA-15	Proportional gain Kp2	0.0~100.0	20.0	√
PA-16	Integral time Ti2	0.01s~10.00s	2.00s	√
PA-17	Derivative time Td2	0.000s~10.000s	0.000s	√
Function Code	Parameter name	Setting range	Default	property
PA-18	PID parameter switchover condition	0:No switchover 1:Switchover via S terminal 2:Automatic switchover based on deviation	0	√
PA-19	PID parameter switchover deviation1	0.0%~PA-20	20.0%	√
PA-20	PID parameter switchover deviation2	PA-19~100.0%	80.0%	√
PA-21	PID initial value	0.0%~100.0%	0.0%	√
PA-22	PID initial value holding time	0.00~650.00s	0.00s	√
PA-23	Maximum deviation between two times PID outputs in forward direction	0.00%~100.00%	1.00%	√
PA-24	Maximum deviation between two times PID outputs in reverse direction	0.00%~100.00%	1.00%	√
PA-25	PID integral property	Unit's digit: Integral separated 0:Invalid 1:Valid Ten's digit: Whether to stop integral operation when the output	00	√



		reaches the limit 0:Continue integral operation 1:Stop integral operation		
PA-26	Detection value of PID feedback loss	0.0%:Not judging feedback loss 0.1%~100.0%	0.0%	√
PA-27	Detection time of PID feedback loss	0.0s~20.0s	0.0s	√
PA-28	PID operation at stop	0:No PID operation at stop 1:PID operation at stop	0	√
Group Pb: Swing Frequency, Fixed Length and Count				
Pb-00	Swing frequency setting mode	0:Relative to the central frequency 1:Relative to the maximum frequency	0	√
Pb-01	Swing frequency amplitude	0.0%~100.0%	0.0%	√
Pb-02	Swing frequency amplitude	0.0%~50.0%	0.0%	√
Pb-03	Swing frequency cycle	0.1s~3000.0s	10.0s	√
Pb-04	Triangular wave rising time coefficient	0.1%~100.0%	50.0%	√
Pb-05	Set length	0m~65535m	1000m	√
Pb-06	Actual length	0m~65535m	0m	√
Pb-07	Number of pulses parameter	0.1~6553.5	100.0	√
Pb-08	Set count value	1~65535	1000	√
Pb-09	Designated count value	1~65535	1000	√
Group PC Multi-Reference and Simple PLC Function				
PC-00	Multi-Reference 0	-100.0%~100.0%	0.0%	√
PC-01	Multi-Reference 1	-100.0%~100.0%	0.0%	√

PC-02	Multi-Reference 2	-100.0%~100.0%	0.0%	√
PC-03	Multi-Reference 3	-100.0%~100.0%	0.0%	√
PC-04	Multi-Reference 4	-100.0%~100.0%	0.0%	√
PC-05	Multi-Reference 5	-100.0%~100.0%	0.0%	√
PC-06	Multi-Reference 6	-100.0%~100.0%	0.0%	√
PC-07	Multi-Reference 7	-100.0%~100.0%	0.0%	√
PC-08	Multi-Reference 8	-100.0%~100.0%	0.0%	√
PC-09	Multi-Reference 9	-100.0%~100.0%	0.0%	√
PC-10	Multi-Reference 10	-100.0%~100.0%	0.0%	√
PC-11	Multi-Reference 11	-100.0%~100.0%	0.0%	√
PC-12	Multi-Reference 12	-100.0%~100.0%	0.0%	√
PC-13	Multi-Reference 13	-100.0%~100.0%	0.0%	√
PC-14	Multi-Reference 14	-100.0%~100.0%	0.0%	√
PC-15	Multi-Reference 15	-100.0%~100.0%	0.0%	√
PC-16	Simple PLC running mode	0:Stop after the AC drive runs one cycle 1:Keep final values after the AC drive runs one cycle 2:Repeat after the AC drive runs one cycle	0	√
PC-17	Simple PLC retentive selection	Unit's digit: Retentive upon power failure 0:No retentive 1:retentive Ten's digit :Retentive upon stop 0:No retentive 1:retentive	00	√
PC-18	Running time of simple PLC reference 0	0.0s ( h ) ~6553.5s ( h )	0.0s ( h )	√
PC-19	Acceleration/Deceleration time of simple PLC reference 0 selection	0~3	0	√
PC-20	Running time of simple PLC reference	0.0s ( h ) ~6553.5s ( h )	0.0s ( h )	√

	1			
PC-21	Acceleration/ Deceleration time of simple PLC reference 1 selection	0~3	0	√
Function Code	Parameter name	Setting range	Default	Property
PC-22	Running time of simple PLC reference 2	0.0s ( h ) ~6553.5s ( h )	0.0s ( h )	√
PC-23	Acceleration/ Deceleration time of simple PLC reference 2 selection	0~3	0	√
PC-24	Running time of simple PLC reference 3	0.0s ( h ) ~6553.5s ( h )	0.0s ( h )	√
PC-25	Acceleration/ Deceleration time of simple PLC reference 3 selection	0~3	0	√
PC-26	Running time of simple PLC reference 4	0.0s ( h ) ~6553.5s ( h )	0.0s ( h )	√
PC-27	Acceleration/ Deceleration time of simple PLC reference 4 selection	0~3	0	√
PC-28	Running time of simple PLC reference 5	0.0s ( h ) ~6553.5s ( h )	0.0s ( h )	√
PC-29	Acceleration/ Deceleration time of simple PLC reference 5 selection	0~3	0	√
PC-30	Running time of simple PLC reference 6	0.0s ( h ) ~6553.5s ( h )	0.0s ( h )	√
PC-31	Acceleration/ Deceleration time of simple PLC reference 6 selection	0~3	0	√

PC-32	Running time of simple PLC reference 7	0.0s ( h ) ~6553.5s ( h )	0.0s ( h )	√
PC-33	Acceleration/Deceleration time of simple PLC reference 7 selection	0~3	0	√
PC-34	Running time of simple PLC reference 8	0.0s ( h ) ~6553.5s ( h )	0.0s ( h )	√
PC-35	Acceleration/Deceleration time of simple PLC reference 8 selection	0~3	0	√
PC-36	Running time of simple PLC reference 9	0.0s ( h ) ~6553.5s ( h )	0.0s ( h )	√
PC-37	Acceleration/Deceleration time of simple PLC reference 9 selection	0~3	0	√
PC-38	Running time of simple PLC reference 10	0.0s ( h ) ~6553.5s ( h )	0.0s ( h )	√
PC-39	Acceleration/Deceleration time of simple PLC reference 10 selection	0~3	0	√
PC-40	Running time of simple PLC reference 11	0.0s ( h ) ~6553.5s ( h )	0.0s ( h )	√
PC-41	Acceleration/Deceleration time of simple PLC reference 11 selection	0~3	0	√
PC-42	Running time of simple PLC reference 12	0.0s ( h ) ~6553.5s ( h )	0.0s ( h )	√

PC-43	Acceleration/ Deceleration time of simple PLC reference 12 selection	0~3	0	√
PC-44	Running time of simple PLC reference 13	0.0s ( h ) ~6553.5s ( h )	0.0s ( h )	√
PC-45	Acceleration/ Deceleration time of simple PLC reference 13selection	0~3	0	√
PC-46	Running time of simple PLC reference 14	0.0s ( h ) ~6553.5s ( h )	0.0s ( h )	√
PC-47	Acceleration/ Deceleration time of simple PLC reference 14 selection	0~3	0	√
PC-48	Running time of simple PLC reference 15	0.0s ( h ) ~6553.5s ( h )	0.0s ( h )	√
PC-49	Acceleration/ Deceleration time of simple PLC reference 15 selection	0~3	0	√
PC-50	Time unit of simple PLC running	0:s ( second ) 1:h ( hour )	0	√
PC-51	Multi-Reference 0 setting mode	0:function code PC-00 setting 1:A11 2:A12 3:A13 4:HDI Pulse setting 5:PID 6:preset frequency ( P5-08 ) setting , modified via terminal UP/DOWN	0	√

Group Pd Communication Parameters				
Function Code	Parameter Name	Setting Range	Default	Property
Pd-00	Baud rate	Unit's digit: MODBUS 0:300BPS 1:600BPS 2:1200BPS 3:2400BPS 4:4800BPS 5:9600BPS 6:19200BPS 7:38400BPS 8:57600BPS 9:115200BPS Ten's digit: reserved Hundred's digit: reserved Thousand's digit: CANlink baud rate 0:20 1:50 2:100 3:125 4:250 5:500 6:1M	6005	√

Pd-01	MODBUS Data format	0:No check ( 8-N-2 ) 1:Even parity check ( 8-E-1 ) 2:Odd Parity check ( 8-O-1 ) 3:No check 8-N-1 ( MODBUS Valid )	0	√
Pd-02	Local address	1~247 , 0 Broadcast address	1	√
Pd-03	Response delay	0ms~20ms (Valid fo MODBUS)	2	√
Pd-04	Time for Communication timeout	0.0 ( invalid ) , 0.1s~60.0s ( Valid for MODBUS )	0.0	√
Pd-05	Reserved			
Pd-06	Communication reading	0:0.01A 1:0.1A	0	√

Group PP Function Code Management				
Function Code	Parameter name	Setting range	Default	Property
PP-00	User password	0~65535	0	√
PP-01	Parameter initialization	0:No operation 01:Restore factory settings except motor parameters 02:Clear records 04:Backup user current parameters 05:Restore the user backup parameters	0	×
PP-02	Function parameter group display selection	Unit's digit: Group U display selection 0:Not display 1:Display Ten's digit: Group U display selection 0:roup d display selection 1:Display	11	×

PP-03	Individualized parameter display selection	Unit's digit: ser-defied parameter display selection 0:Not display 1:Display ( --u—Group ) Ten's digit: User-modified parameter group display selection 0:Not display 1:Display ( --c—group )	00	√
PP-04	Parameter modification property	0:Modifiable 1:Not modifiable	0	√
Group H0 Torque control parameters				
H0-00	Speed/Torque control selection	0:Speed control 1:Torque control	0	×
H0-01	Torque setting source selection in torque control	0:Digital setting 1 ( H0-03 ) 1:A11 2:A12 3:A13 4:HDI Pulse setting 5:Communication setting 6:MIN ( A11,A12 ) 7:MAX( A11,A12 ) Full range of values 1-7 ,corresponds to the digital setting H0-03 )	0	×
H0-03	Torque digital setting in torque control	-200.0%~200.0%	150.0%	√
H0-05	Forward direction maximum frequency in torque control	0.00Hz~maximum frequency	50.00Hz	√
H0-06	Reverse direction maximum frequency in torque control	0.00Hz~maximum frequency	50.00Hz	√



H0-07	Acceleration time in Torque control	0.00s~65000s	0.00s	√
H0-08	Deceleration time in Torque control	0.00s~65000s	0.00s	√
Group H1 Virtual IO				
H1-00	Virtual XS1 terminal function selection	0~59	0	×
H1-01	Virtual XS2 terminal function selection	0~59	0	×
H1-02	Virtual XS3 terminal function selection	0~59	0	×
H1-03	Virtual XS4 terminal function selection	0~59	0	×
H1-04	Virtual XS5 terminal function selection	0~59	0	×
H1-05	Virtual XS input terminal state setting mode	0: Valid or not for the XS, It is decided by the state of virtual XDOx 1: XS valid or not is decided by the function code C1—06 setting. Unit's digit: virtual XS1 Ten's digit: virtual XS2 Hundred's digit: virtual XS3 Thousand's digit: virtual XS4 Ten thousand's digit: virtual XS5	00000	×

Function code	Parameter name	Setting Range	Default	Property
H1-06	Virtual XS input terminal state setting	0:invalid 1:valid Unit's digit : virtual XS1 Ten's digit : virtual XS2 Hundred's digit : virtual XS3 Thousand's digit : virtual XS4 Ten thousand's digit : virtual XS5	00000	×

H1-07	Function selection for AI1 as S	0~59	0	×
H1-08	Function selection for AI2 as S	0~59	0	×
H1-09	Function selection for AI3 as S	0~59	0	×
H1-10	Effective model selection for V terminal as S	0:High level valid 1:Low level valid Unit's digit:AI1 Ten's digit:AI2 Hundred's digit:AI3	000	×
H1-11	Virtual XDO1 Output function selection	0:Short with physicalSx internally 1~40:Refer to group H5 physical DO output selection	0	√
H1-12	Virtual XDO2 Output function selection	0:Short with physical Sx internally 1~40: Refer to group H5 physical DO output selection	0	√
H1-13	Virtual XDO3 Output function selection	0:Short with physical Sx internally 1~40: Refer to group H5 physical DO output selection	0	√
H1-14	Virtual XDO4 Output function selection	0:Short with physical Sx internally 1~40: Refer to group H5 physical DO output selection	0	√
H1-15	Virtual XDO5 Output function selection	0:Short with physical Sx internally 1~40: Refer to group H5 physical DO output selection	0	√
H1-16	Virtual XDO1 output delay time	0.0s~3600.0s	0.0s	√
H1-17	Virtual XDO2 output delay time	0.0s~3600.0s	0.0s	√

H1-18	Virtual XDO3 output delay time	0.0s~3600.0s	0.0s	√
H1-19	Virtual XDO4 output delay time	0.0s~3600.0s	0.0s	√
H1-20	Virtual XDO5 output delay time	0.0s~3600.0s	0.0s	√
H1-21	Virtual XDO output terminal effective state selection	0:Positive logic 1:Reverse logic Unit's digit :XDO1 Ten's digit :XDO2 Hundred's digit :XDO3 Hundred's digit :XDO4 Ten thousand's digit :XDO5	00000	√
Group H2 Motor 2 Control				
H2-00	Motor type selection	0:Common asynchronous motor 1:Variable frequency asynchronous motor 2:Permanent magnetic synchronous motor	0	×
H2-01	Rated motor power	0.1kW~1000.0kW	Model dependent	×
H2-02	Rated motor power	1V~2000V	Model dependent	×
H2-03	Rated motor current	0.01A~655.35A ( drive power ≤ 55kW ) 0.1A~6553.5A ( drive power > 55kW )	Model dependent	×
H2-04	Rated motor frequency	0.01Hz~maximum power	Model dependent	×
H2-05	Rated motor rotational speed	1rpm~65535rpm	Model dependent	×

H2-06	Stator resistance (asynchronous motor)	0.001Ω~65.535Ω ( drive power ≤55kW ) 0.0001Ω~6.5535Ω ( drive power >55kW )	Model dependent	×
H2-07	Rotor resistance (asynchronous motor)	0.001Ω~65.535Ω ( drive power ≤55kW ) 0.0001Ω~6.5535Ω ( drive power >55kW )	Model dependent	×
H2-08	Leakage inductive reactance (asynchronous motor)	0.01mH~655.35mH ( drive power ≤55kW ) 0.001mH~65.535mH ( drive power >55kW )	Model dependent	×
H2-09	Mutual inductive reactance(asynchrono us motor)	0.1mH~6553.5mH ( drive power ≤55kW ) 0.01mH~655.35mH ( drive power >55kW )	Model dependent	×
H2-10	No-load current (asynchronous motor)	0.01A~H2-03 (drive power ≤55kW ) 0.1A~H2-03 (drivepower >55kW)	Model dependent	×
H2-16	Stator resistance (synchronous motor)	0.001Ω~65.535Ω ( drive power ≤55kW ) 0.0001Ω~6.5535Ω ( drive power >55kW )	Model dependent	×
H2-17	Shaft D inductance (synchronous motor)	0.01mH~655.35mH ( drive power ≤55kW ) 0.001mH~65.535mH ( drive power >55kW )	Model dependent	×
H2-18	Shaft Q inductance (synchronous motor)	0.01mH~655.35mH ( drive power ≤55kW ) 0.001mH~65.535mH ( drive power >55kW )	Model dependent	×
H2-20	Back EMF (synchronous motor)	0.1V~6553.5V	Model dependent	×
H2-27	The encoder line	1~65535	1024	×

H2-28	Encoder type	0:ABZ incremental encoder 1:UVW incremental encoder 2:Resolver 3:SIN/COS encoder 4:Wire-saving UVW encoder	0	×
H2-29	Speed feedback PG selection	0:Local PG 1:extensive PG 2:HDI impulse input ( S5 )	0	×
H2-30	A, B phase sequence of ABZ incremental encoder	0:Forward 1:Reserve	0	×
H2-31	Encoder installation angle	0.0°~359.9°	0.0°	×
H2-32	Reserved			
H2-33	Reserved			
H2-34	Reserved			
Function Code	Parameter name	Setting range	Default	Property
H2-36	Speed feedback PG wire-break detection time	0.0:No action 0.1s~10.0s	0.0	×
H2-37	Auto-tuning selection	0:No auto-tuning 1:Asynchronous motor static auto-tuning 2:Asynchronous motor complete auto-tuning 11:Synchronous motor with-load auto-tuning 12:Synchronous motor no-load auto-tuning	0	×
H2-38	Speed loop proportional gain 1	1~100	30	√
H2-39	Speed loop integral time 1	0.01s~10.00s	0.50s	√

H2-40	Switchover frequency 1	0.00~H2-43	5.00Hz	√
H2-41	Speed loop proportional gain 2	1~100	20	√
H2-42	Speed loop integral time 2	0.01s~10.00s	1.00s	√
H2-43	Switchover frequency 2	H2-40~maximum frequency	10.00Hz	√
H2-44	Vector control slip gain	50%~200%	100%	√
H2-45	Time constant of speed loop filter	0.000s~0.100s	0.000s	√
H2-46	Vector control Over-excitation gain	0~200	64	√
H2-47	Torque upper limit source in speed control mode	0:H2-48 setting 1:A1 2:A12 3:A13 4:HDI Pulse setting 5:communication setting 6:MIN ( A,A12 ) 7:MAX ( A11,A12 ) Full range of options of 1-7 , corresponding to H2-48 digital setting	0	√
H2-48	Digital setting of Torque upper limit in speed controlmode	0.0%~200.0%	150.0%	√
H2-51	Excitation adjustment proportional gain	0~20000	2000	√
H2-52	Excitation adjustment integral gain	0~20000	1300	√
H2-53	Torque adjustment proportional gain	0~20000	2000	√

Function Code	Parameter Name	Setting range	Default	Property
H2-54	Torque adjustment integral gain	0~20000	1300	√
H2-55	Speed loop integral property	Unit's digit: Integral separated 0:Invalid	0	√
H2-56	Field weakening mode of synchronous motor	0:No field weakening 1:Direct calculation 2:Adjustment	1	√
H2-57	Field weakening degree of synchronous motor	50%~500%	100%	√
H2-58	Maximum field weakening current	1%~300%	50%	√
H2-59	Field weakening automatic adjustment	10%~500%	100%	√
H2-60	Field weakening integral multiple	2~10	2	√
H2-61	Motor 2 control mode	0:speed sensor-less vector control ( SVC ) 1:speed sensor vector control ( FVC ) 2:V/Fcontrol	0	×
H2-62	Motor 2 acceleration/Deceleration time	0:Same as motor 1 1:Acceleration/Deceleration time 1 2:Acceleration/Deceleration time 2 3:Acceleration/Deceleration time 3 4:Acceleration/Deceleration time 4	0	√
H2-63	Motor 2 torque boost	0.0%:Automatic torque boost 0.1%~30.0%	Model dependent	√
H2-65	Motor 2 oscillation suppression gain	0~100	Model dependent	√
Group H5 Control Optimization Parameters				

H5-00	DPWM switchover frequency upper limit	0.00Hz~15.00Hz	12.00Hz	√
H5-01	PWM modulation model	0:Asynchronous modulation 1:Synchronous modulation	0	√
H5-02	Dead zone compensation mode selection	0:No compensation 1:Compensation mode 1 2:Compensation mode 1	1	√
H5-03	Random PWM depth	0:Random PWM invalid 1~10:PWMcarrier frequency random depth	0	√
H5-04	Rapid current limit	0:Disabled 1:Enabled	1	√
H5-05	Current detection compensation	0~100	5	√
Function Code	Parameter Name	Setting range	Default	Property
H5-06	Under-voltage threshold setting	60.0%~140.0%	100.0%	√
H5-07	SVC optimization mode selection	0:No optimization 1:Optimization mode 1 2:Optimization mode 2	1	√
H5-08	Dead-zone time adjustment	100%~200%	150%	√
H5-09	Overvoltage threshold setting	200.0V~2500.0V	Model dependent	×
Group H6 AI analog input curve setting				
H6-00	AI curve 4 minimum input	-10.00V~H6-02	0.00V	√
H6-01	Corresponding setting of AI curve 4 minimum input	-100.0%~+100.0%	0.0%	√
H6-02	AI curve 4 inflexion 1 input	H6-00~H6-04	3.00V	√



H6-03	Corresponding setting of AI curve 4 inflexion 1 input	-100.0%~+100.0%	30.0%	√
H6-04	AI curve 4 inflexion 2 input	H6-02~H6-06	6.00V	√
H6-05	Corresponding setting of AI curve 4 inflexion 2 input Setting	-100.0%~+100.0%	60.0%	√
H6-06	AI curve 4 maximum input	H6-06~+10.00V	10.00V	√
H6-07	Corresponding setting of AI curve 4 maximum input	-100.0%~+100.0%	100.0%	√
H6-08	AI curve 5 minimum input	-10.00V~H6-10	-10.00V	√
H6-09	Corresponding setting of AI curve 5 minimum input	-100.0%~+100.0%	-100.0%	√
H6-10	AI curve 5 inflexion 1 input	H6-08~H6-12	-3.00V	√
H6-11	Corresponding setting of AI curve 5 inflexion 1 input	-100.0%~+100.0%	-30.0%	√
H6-12	AI curve 5 inflexion 2 input	H6-10~H6-14	3.00V	√
H6-13	Corresponding setting of AI curve 5 inflexion 2 input	-100.0%~+100.0%	30.0%	√
H6-14	AI curve 5 maximum input	H6-12~+10.00V	10.00V	√
H6-15	Corresponding setting of	-100.0%~+100.0%	100.0%	√
H6-24	Jump point setting of AI1	-100.0%~100.0%	0.0%	√

H6-25	Jump amplitude setting of AI1	0.0%~100.0%	0.5%	√
H6-26	Jump point setting of AI2	-100.0%~100.0%	0.0%	√
H6-27	Jump amplitude setting of AI2	0.0%~100.0%	0.5%	√
H6-28	Jump point setting of AI3	-100.0%~100.0%	0.0%	√
H6-29	Jump amplitude setting of AI3	0.0%~100.0%	0.5%	√
Group HC Analog input/output correction				
HC-00	AI1 measured voltage 1	0.500V~4.000V	factory calibrated	√
HC-01	AI1 displayed voltage 1	0.500V~4.000V	factory calibrated	√
HC-02	AI1 measured voltage 2	6.000V~9.999V	factory calibrated	√
HC-03	AI1 displayed voltage 2	6.000V~9.999V	factory calibrated	√
HC-04	AI2 measured voltage 1	0.500V~4.000V	factory calibrated	√
HC-05	AI2 displayed voltage 1	0.500V~4.000V	factory calibrated	√
HC-06	AI2 measured voltage 2	6.000V~9.999V	factory calibrated	√
HC-07	AI2 displayed voltage 2	6.000V~9.999V	factory calibrated	√
HC-08	AI3 measured voltage 1	-9.999V~10.000V	factory calibrated	√
HC-09	AI3 displayed voltage 1	-9.999V~10.000V	factory calibrated	√
HC-10	AI3 measured voltage 2	-9.999V~10.000V	factory calibrated	√

HC-11	AI3 displayed voltage 2	-9.999V~10.000V	factory calibrated	√
HC-12	A01 target voltage 1	0.500V~4.000V	factory calibrated	√
HC-13	A01 measured voltage 1	0.500V~4.000V	factory calibrated	√
HC-14	A01 target voltage 2	6.000V~9.999V	factory calibrated	√
HC-15	A01 measured voltage 2	6.000V~9.999V	factory calibrated	√
HC-16	A02 target voltage 1	0.500V~4.000V	factory calibrated	√
HC-17	A02 measured voltage 1	0.500V~4.000V	factory calibrated	√
HC-18	A02 target voltage 2	6.000V~9.999V	factory calibrated	√
HC-19	A02 measured voltage 2	6.000V~9.999V	factory calibrated	√

Monitoring Parameters Table:

Function Code	Parameter Name	Minimum Unit	Communication Address
Group d0 Basic monitoring parameters			
U0-00	Running frequency ( Hz )	0.01Hz	7000H
U0-01	Set frequency ( Hz )	0.01Hz	7001H
U0-02	Bus voltage ( V )	0.1V	7002H
U0-03	Output voltage ( V )	1V	7003H
U0-04	Output current ( A )	0.01A	7004H
U0-05	Output power ( kW )	0.1kW	7005H
U0-06	Output torque ( % )	0.1%	7006H
U0-07	DI terminal input state	1	7007H
U0-08	DO terminal output state	1	7008H

U0-09	AI1 voltage ( V )	0.01V	7009H
U0-10	AI2 voltage ( V )	0.01V	700AH
U0-11	AI3 voltage ( V )	0.01V	700BH
U0-12	Count value	1	700CH
U0-13	Length value	1	700DH
U0-14	Load speed display	1	700EH
U0-15	PID setting	1	700FH
U0-16	PID feedback	1	7010H
U0-17	PLC stage	1	7011H
U0-18	HDI Input pulse frequency ( Hz )	0.01kHz	7012H
U0-19	Feedback speed ( unit 0.01Hz )	0.01Hz	7013H
U0-20	Remaining running time	0.1Min	7014H
U0-21	AI1voltage before correction	0.001V	7015H
U0-22	AI2 voltage before correction	0.001V	7016H
U0-23	AI3 voltage before correction	0.001V	7017H
U0-24	Linear speed	1m/Min	7018H
U0-25	current power-on time	1Min	7019H
U0-26	Current running time	0.1Min	701AH
U0-27	HDI Pulse input frequency	1Hz	701BH
U0-28	Communication setting value	0.01%	701CH
U0-29	Encoder feedback speed	0.01Hz	701DH
U0-30	Main frequency A display	0.01Hz	701EH
U0-31	Main frequency B display	0.01Hz	701FH
U0-32	Viewing any register address value	1	7020H

U0-33	Synchronous motor rotor position	0.1°	7021H
U0-34	Motor temperature	1°C	7022H
U0-35	Target torque ( % )	0.1%	7023H
U0-36	Resolver position	1	7024H
U0-37	Power factor angle	0.1°	7025H
U0-38	ABZ position	1	7026H
U0-39	Target voltage upon V/F separation	1V	7027H
U0-40	Output voltage upon V/F separation	1V	7028H
U0-41	DI terminal input state visual display	1	7029H
U0-42	DO terminal output state visual display	1	702AH
U0-43	DI terminal function state visual display 1 ( function 01-function 40 )	1	702BH
U0-44	DI terminal function state visual display 2 ( function 41- function 80 )	1	702CH
U0-45	Reserved		702DH
U0-58	Reserved		703AH
U0-59	Setting frequency ( % )	0.01%	703BH
U0-60	Running frequency ( % )	0.01%	703CH
U0-61	Drive state	1	703DH
U0-62	current fault code	1	703EH
U0-63	Reserved	-	
U0-64	reserved	-	
U0-65	Torque upper limit	0.01%	7041H

## Chapter6 Description of Function Codes

### Group P0 Basic Parameters

	GP type setting		Default	Related to the motor
P0-00	Setting range	1	G type ( constant torque load )	
		2	P type ( variable torque load e.g. fan and	

1:Applicable to constant torque load with rated parameters specified

2:Applicable to variable torque load (fan and pump) with rated parameters specified.

	Motor 1 control mode		Default	0
P0-01	Setting range	0	Speed sensor-less vector control ( SVC )	
		1	Vector control with speed sensor ( FVC )	
		2	V/F control	

0:Speed sensor-less vector control

It indicates open-loop vector control, and is applicable to high-performance control applications such as machine tool, centrifuge, wire drawing machine and injection molding machine. One AC drive can operate only one motor.

1:Vector control with speed sensor is the same meaning with Closed-loop vector control ,An encoder must be installed at the motor side, and a PG card matching theencoder must be installed at the AC drive side. It is applicable to high-accuracy speed control or torque control applications such as high-speed paper making machine, crane and elevator. One AC drive can operate only one motor.

2:It is applicable to applications with low load requirements or applications where one AC drive operates multiple motors, such as fan and pump. It can be used in the condition one AC drive operating multiple motor.

If the vector control is used, motor parameter identification process must be operated. the advantages of vector control can only be utilized after correct motor parameters are obtained. Better performance can be achieved by adjusting speed regulator parameters Group H2 function code(Group C2

respectively for Motor2)

For the permanent magnetic synchronous motor, closed-loop vector control (Vector control with speed sensor) is the general choice. In some low-power motor applications, you can also use V/F control. CM540 does not support Speed sensor-less vector control for the permanent magnetic synchronous motor.

P0-02	Command source selection		Default	0
	Setting range	0	Operation panel command channel ( LED off )	
		1	Terminal command channel ( LED on )	
		2	Communication command channel ( LED blinking )	

To select the input channel of the drive control command.

Drive control command includes: Start、 Stop 、 rive control command、 reverse rotation、 jog operation and so on.

0:Operation panel command channel( “LOCAL/REMOT” indicator off ); Running command controls are given by pressing keys RUN、 STOP/RESET on the operation panel.

1:Terminal command channel ( “LOCAL/REMOT” indicator on ) ; The running command control is given by the multi-function input terminal FWD、 REV、 JOGF、 JOGR and so on.

2:Communication command channel ( “LOCAL/REMOT” indicator blanking )  
Running commands are given from host computer. The function parameter related to the communication , please refer to related description about “Group HD communication parameter”.

P0-03	Main frequency source A selection	Default	0
-------	-----------------------------------	---------	---

Range setting	0	Digital setting ( The preset frequency P0-08 , UP/DOWN Modifiable non-retentive at power failure )
	1	Digital setting ( The preset frequency P0-08 , UP/DOWN Modifiable , retentive at power. failure )
	2	A11
	3	A12
	4	A13
	5	Pulse setting ( S5 )
	6	Multi-reference
	7	PLC
	8	PID
	9	Communication setting

It is used to select the setting channel of the main frequency. You can set the main frequency in the following 10 channels:

0:Digital setting ( non-retentive at power failure )

The initial value of the set frequency is the preset frequency value of P0-08. You can change the set frequency by pressing ▲ and ▼ on the operation panel ( or using the UP/DOWN function of input terminals ) .

When the AC drive is powered on again after power failure, the set frequency reverts to the value of P0-08.

1:Digital setting ( retentive at power failure )

The initial value of the set frequency is the preset frequency value of P0-08.



You can change the set frequency by pressing ▲ and ▼ on the operation panel ( or using the UP/DOWN function of input terminals ) .

When the AC drive is powered on again after power failure, the set frequency is the value memorized at the moment of the last power failure. The value is retentive through the key ▲、▼ or through the set frequency of UP、DOWN terminals.

Note that P0-23 is “Retentive of digital setting frequency upon power failure”. P0-23 is used in determining whether the set frequency is memorized or cleared when the AC drive stops. It is related to stop rather than power failure retentive. This should be noted in the application.

2:AI1

3:AI2

4:AI3

The frequency is set by analog input. The CM540 control board provides two analog input terminals (AI1, AI2). Another one terminal (AI3) is provided by the I/O extension card.

Among them , AI1 is 0V~10V voltage Input type , AI2 can be 0V~10V voltage Input , it also can be 4mA~20mA current input , determined by jumper wires selection on the control board , AI3 is 0V~10V voltage input type.

Users can freely chose the mapping relationship between the input voltage value of AI1, AI2 and AI3 and the target frequency. CM540 provides 5 mapping relationship curves, three of which are linear (2-points correspondence) and two of which are four-point correspondence curves. Users can set the curves by using function codes in Group H4 AND Group C6.

Function code P4-33 is used for setting AI1~I3 analog input, and determines which one to choose in the 5 Group Curves. And the detailed corresponding

relations of the 5 curves, please refer to the description of Group H4, Group C6 function code.

#### 5:Pulse setting ( DI6 )

The frequency is set by terminal pulse(high-speed pulse). The signal specification of pulse setting is 9–30 V (voltage range) and 0–100 kHz (frequency range). Pulse setting can be input just through Multi-function input terminals DI6.

For the relations between DI6 terminal input pulse frequency and correspondence setting, it is set by P4-28~P4-31. It is point-point straight lines corresponding relations.

The corresponding value 100% of pulse setting corresponds to percentages of the value P0-10 (Maximum frequency).

#### 6:Multi-reference

In multi-reference mode, combinations of different DI terminal states correspond to different set frequencies values. The CM540 supports a maximum of 16 speeds implemented by 16 state combinations of four DI terminal in Group FC. The multiple references indicate percentages of the value of F0-10(Maximum frequency).

If a digital DI terminal is used for the multi-reference function, please refer to the related function parameters setting in group H4.

#### 7:Simple PLC

When the simple programmable logic controller (PLC) mode is used as the frequency source, the running frequency of the AC drive can be switched over among the 16 frequency references. You can set the holding time and acceleration/deceleration time of the 16 frequency references. For details, refer to the descriptions of Group FC..

#### 8:PID

The output of PID control is used as the running frequency. PID control is generally used in on-site closed-loop control, such as constant pressure closed-loop control and constant tension closed-loop control.

When applying PID as the frequency source, you need to set parameters of PID

in Group HA.

9:Communication setting The frequency is set by means of communication..

CM540 supports 2 communication protocols: s: Modbus-RTU 、CANlink, the communication protocols can not be used at the same time.

When stalling the extension card 2(EXT2-IO) in the CANlink communication mode, it needs to set the parameter P5-28(Communication extension card type) correctly.

P0-04	Auxiliary frequency source B selection		Default	0
	Setting range	0	Digital setting ( preset frequency P5-08 , UP/DOWN Modifiable non-retentive at power failure )	
		1	Digital setting ( preset frequency P5-08 , UP/DOWN Modifiable , retentive at power failure )	
		2	AI1	
		3	AI2	
		4	AI3	
		5	Pulse setting ( DI6 )	
		6	Multi-reference	
		7	PLC	
		8	PID	
9		Communication setting		

When used as an independent frequency input channel (frequency source switched over from A to B), the auxiliary frequency source B is used in the same way as the main frequency source A (Please refer to the description of P5-03 )

When the auxiliary frequency source is used for superposition setting ( the frequency source is A+B, the switchover between A and A+B, the switchover between B and A+B), pay attention to the following aspects:

a ) If the auxiliary frequency source B is digital setting, the preset frequency (P5-08) does not take effect. You can directly adjust the set main frequency by pressing keys ▲ and ▼ on the operation panel (or using the UP/DOWN function of input terminals) .

b ) If the auxiliary frequency source is analog input (AI1 , AI2 and AI3) or pulse setting, 100% of the input setting corresponds to the range of the auxiliary frequency B, Please set P0-05 and P0-06.

c ) If the auxiliary frequency source is pulse setting, it is similar to analog input.

Note: The main frequency source A and auxiliary frequency source B must not use the same channel. That is, P0-03 and P0-04 cannot be set to the same value. Or it will cause confusion.

P0-05	Range of auxiliary frequency B for A and B operation		Default	0
	Setting range	0	Relative to maximum frequency	
		1	Relative to main frequency source A	
P0-06	Range of auxiliary frequency B for A and B operation		Default	0
	Setting range		0%~150%	

If the frequency source is superposition frequency(A and B operation), P0-05 and P0-06 are used to set the adjustment range of the auxiliary frequency source.

You can set the auxiliary frequency to be relative to either maximum frequency or main frequency A. If relative to main frequency A, the setting range of the auxiliary frequency B varies according to the main frequency X.

PO-07	Frequency source superposition		Default	0
	Setting range	Digit Unit	Frequency source selection	

		0	Main frequency source A
		1	The result of A and B operation (operation relationship determined by ten's digit)
		2	Switchover between A and B
		3	Switchover between A and "A and B operation"
		4	Switchover between B and "A and B operation"
		Ten Unit	A and B operation relationship
		0	A+B
		1	A-B
		2	Maximum
		3	Minimum

It is used to select the frequency setting channel. The frequency setting can be achieved through A and B recombination

If the frequency source involves A and B operation, you can set the frequency offset in P0-21 for superposition to the X and Y operation result, flexibly satisfying various requirements.

P0-08	Preset frequency	Default	50.00Hz
	Setting range	0.00~maximum frequency ( valid when frequency source is digital setting )	

If the frequency source is digital setting or terminal UP/DOWN, the value of this parameter is the initial frequency of the AC drive (digital setting).

P0-09	Running direction		Default	0
	Setting range	0	Same direction	
		1	Reverse direction	

You can change the rotation direction of the motor just by modifying this parameter without changing the motor wiring. Modifying this parameter is equivalent to exchanging any two of the motor's U, V, W wires.

Note: The motor will resume running in the original direction after parameter initialization. Do not use this function in applications where changing the rotating direction of the motor is prohibited after system commissioning is complete.

P0-10	Maximum frequency	Default	50.00 Hz
	Setting range	50.00Hz~320.00Hz	

In CM540, when the frequency source is analog input, pulse setting, or multi-reference, 100% of the input corresponds to the value of this parameter.

The output frequency of the CM540 can reach up to 3200 Hz. To take both frequency reference resolution and frequency input range into consideration, you can set the number of decimal places for frequency reference in P0-22.

P0-22 is set to 1, the frequency reference resolution is 0.1 Hz. In this case, the setting range of P0-10 is 50.0 to 3200.0 Hz;

If P0-22 is set to 2, the frequency reference resolution is 0.01 Hz. In this case, the setting range of P0-10 is 50.00 to 320.00 Hz.

Note: After the value of P5-22 is modified, the frequency resolution of all frequency related function codes change accordingly.

P0-11	Source of frequency upper limit		Default	0
	Setting range	0	P0-12 setting	
		1	AI1	
		2	AI2	
		3	AI3	
		4	HDI setting ( DI6 terminal )	

		5	Communication setting
--	--	---	-----------------------

The definition of the source of the frequency upper limit. It can come from digital setting (P0-12), analog input, HDI and communication setting. If the frequency upper limit is set by analog input, setting of the analog input is 100% corresponding to P0-12.

For example, to avoid runaway in torque control mode in winding application, you can set the frequency upper limit by means of analog input. When the AC drive reaches the upper limit, it will continue to run at this speed.

P0-12	Frequency upper limit	Default	50.00Hz
	Setting range	Frequency lower limit P0-14~Maximum frequency P0-10	
P0-13	Frequency upper limit offset	Default	0.00Hz
	Setting range	0.00Hz~ Maximum frequency PO-10	

If the source of the frequency upper limit is analog input or HDI setting, P5-13 is set as the value of the offset. The final frequency upper limit is obtained by adding the offset frequency in this parameter to the frequency upper limit set in P5-11.

P0-14	Frequency lower limit	Default	0.00Hz
	Setting range	0.00Hz~frequency upper limit PO-12	

If the frequency reference is lower than the value of this parameter P0-14, the AC drive can stop, run at the frequency lower limit, or run at zero speed, the running mode is determined by F8-14( setting frequency is lower than the frequency lower limit) set.

P0-15	Carrier frequency	Default	Model dependent
	Setting range	0.5kHz~16.0kHz	

It is used to adjust the carrier frequency of the AC drive, helping to reduce the

motor noise, avoiding the resonance of the mechanical system, and reducing the leakage current to the earth and interference generated by the AC drive.

If the carrier frequency is low, output current has high harmonics, and the power loss and temperature rise of the motor increase. If the carrier frequency is high, power loss and temperature rise of the motor declines. However, the AC drive has an increase in power loss, temperature rise and interference.

Adjusting the carrier frequency will exert influences on the aspects listed in the following table:

Carrier frequency	Low → High
Motor noise	Large → Small
Output current waveform	Bad → Good
Motor temperature rise	High → Low
AC drive temperature rise	Low → High
Leakage current	Small → Large
External radiation interference	Small → Large

The factory setting of carrier frequency varies with the AC drive power. If you need to modify the carrier frequency, note that if the set carrier frequency is higher than factory setting, it will lead to an increase in temperature rise of the AC drive's heatsink. In this case, you need to de-rate the AC drive. Otherwise, the AC drive may overheat and alarm.

P0-16	Carrier frequency adjustment with temperature 0	Default	0
	Setting range	0:No 1:Yes	

It is used to set whether the carrier frequency is adjusted based on the temperature. The AC drive automatically reduces the carrier frequency when detecting that the heatsink

temperature is high. The AC drive resumes the carrier frequency to the set value when the heatsink temperature becomes normal. This function reduces the overheat alarms.



P0-17	Acceleration time 1	Default	Model dependent
	Setting range	0.00s~65000s	
P0-18	Deceleration time 1	Default	Model dependent
	Setting range	0.00s~65000s	

Acceleration time indicates the time required by the AC drive to accelerate from 0 Hz to "Acceleration/Deceleration base frequency" (P0-25), .

Deceleration time indicates the time required by the AC drive to decelerate from "Acceleration/Deceleration base frequency" (P0-25) to 0 Hz.

The CM540 provides totally four groups of acceleration/deceleration time for selection. You can perform switchover selection by using a S terminal. The four groups of acceleration/deceleration time can be set by below function codes:

Group 1:P0-17、 P0-18;

Group 2:P8-03、 P8-04;

Group 3:P8-05、 P8-06;

Group 4:P8-07、 P8-08.

P0-19	Acceleration/Deceleration time unit		Default	1
	Setting range	0	1 second	
		1	0.1 second	
		2	0.01 second	

To satisfy requirements of different applications, the CM540 provides three acceleration/deceleration time units, 1s, 0.1s and 0.01s.

Note: Modifying this parameter will make the displayed decimal places change and corresponding acceleration/deceleration time also change. This should be paid attention to in the application.

P0-21	Frequency offset of auxiliary frequency source for A and B operation	Default	0.00Hz
-------	--	---------	--------

	Setting range	0.00Hz~maximum frequency P0-10
--	---------------	-----------------------------------

This parameter is valid only when the frequency source is set to "A and B operation".

When the frequency source is the A and B operation, P0-21 is set by offset frequency. The final frequency is obtained by adding the frequency offset set in this parameter to the A and B operation result. This make the frequency setting more flexible.

P0-22	Frequency reference resolution		Default	2
	Setting range	1	0.1Hz	
		2	0.01Hz	

It is used to set the resolution of all frequency-related parameters.

If the resolution is 0.1 Hz, the CM540 can output up to 3200 Hz. If the resolution is 0.01 Hz, the CM540 can output up to 600.00 Hz.

Note: Modifying this parameter will make the decimal places of all frequency-related parameters change and corresponding frequency values change. This is should be paid attention to in the application.

P0-23	Retentive of digital setting frequency upon power failure		Default	0
	Setting range	0	Not retentive	
		1	Retentive	

This parameter is valid only when the frequency source is digital setting.

If P0-23 is set to 0, the digital setting frequency value resumes to the value of P0-08 (Preset frequency) after the AC drive stops. The modification by using keys▲and▼ and or the terminal UP/DOWN function is cleared.

If P0-23 is set to 1, the digital setting frequency value is the set frequency at the moment when the AC drive stops. The modification by using keys▲、 and▼ or

the terminal UP/DOWN function remains effective.

P0-24	Motor selection		Default	0
	Setting range	0	Motor 1	
		1	Motor 2	

The CM540 can drive 2 motors at different time. You can set the motor nameplate

parameters respectively, independent motor auto-tuning, different control modes, and parameters related to running performance respectively for the 2 motors.

Motor parameter group 1 corresponds to groups H1 and H2. Motor parameter groups 2 correspond to groups C2 respectively.

You can select the current motor parameter group by using P0-24 or perform switchover between the motor parameter groups by means of a S(Digital input terminals) terminal. If motor parameters selected by means of P0-24 conflict with those selected by means of S terminal, the selection by S is preferred.

P0-25	Acceleration/Deceleration time base frequency		Default	0
	Setting range	0	maximum frequency ( P5-10 )	
		1	Set frequency	
		2	100Hz	

The acceleration/deceleration time indicates the time for the AC drive to increase from 0Hz to the frequency set in P5-25. (Figure 6-1 Acceleration/Deceleration time)

If this parameter is set to 1, the acceleration/deceleration time is related to the set frequency. If the set frequency changes frequently, the motor's acceleration/deceleration also changes.

P0-26	Base frequency for UP/DOWN modification during running		Default	0
	Setting range	0	Running frequency	

		1	Set frequency
--	--	---	---------------

This parameter is valid only when the frequency source is digital setting.

It is used to set the base frequency to be modified by using keys ▲ and ▼ or the terminal UP/DOWN function.

If the running frequency and set frequency are different, there will be a large difference between the AC drive's performance during the acceleration/deceleration process.

	Binding command source	Default	000
P0-27	Unit's digit	Binding operation panel command to frequency source	
	0	No binding	
	1	Frequency source by digital setting	
	2	AI1	
	3	AI2	
	4	AI3	
	5	HDI Pulse setting ( DI6 )	
	6	Multi-reference	
	7	Simple PLC	
	8	PID	
	9	Communication setting	
	P5-27	Ten's digit	Binding terminal command to frequency source ( 0~9 , same as unit's digit )
Hundred's digit		Binding communication command to frequency source ( 0~9 , same as unit's digit )	

It is used to bind the three running command sources with the nine frequency sources, facilitating to implement synchronous switchover.

For details on the frequency sources, see the description of P0-03 (Main

frequency source A selection). Please refer to the P0-03 description of function code. Different running command sources can be bound to the same frequency source.

If a command source has a bound frequency source, the frequency source set in P0-03 to P0-07 no longer takes effect when the command source is effective.

P0-28	Communication extensive card type	Default	0
	Setting range	0	Modbus

### Group P1 Motor 1 Parameters

P1-00	Motor type selection	Default	0
	Setting range	0	Common asynchronous motor
		1	Variable frequency asynchronous motor
		2	Permanent magnetic synchronous motor
P1-01	Rated motor power	Default	Model dependent
	Setting range	0.1kW~1000.0kW	
P1-02	Rated motor voltage	Default	Model dependent
	Setting range	1V~2000V	
P1-03	Rated motor current	Default	Model dependent
	Setting range	0.01A~655.35A (AC drive power <=55kW )	
P1-04	Rated motor power	Default	Model dependent
	Setting range	0.01Hz~maximum frequency	
P1-05	Rated motor rotational speed	Default	Model dependent
	Setting range	1rpm~65535rpm	

Set the parameters according to the motor nameplate no matter whether V/F control or vector control is adopted.

To achieve better V/F or vector control performance, motor auto-tuning is required. The motor auto-tuning accuracy depends on the correct setting of motor nameplate parameters.

P1-06	Stator resistance (asynchronous motor)	Default	Model dependent
	Setting range	0.001Ω~30.000Ω	
P1-07	Rotor resistance (asynchronous motor)	Default	Model dependent
	Setting range	0.001Ω~65.535Ω (AC drive power ≤55kW) 0.0001Ω~6.5535Ω (AC drive power >55kW)	
P1-08	Leakage inductive reactance	Default	Model dependent
	Setting range	0.01mH~655.35mH (AC drive power ≤55kW) 0.001mH~65.535mH (AC drive power >55kW)	
P1-09	Mutual inductive reactance (asynchronous motor)	Default	Model dependent
	Setting range	0.1mH~6553.5mH (AC drive power ≤55kW) 0.01mH~655.35mH (AC drive power >55kW)	
P1-10	No-load current (asynchronous motor)	Default	Model dependent
	Setting range	0.01A~P1-03 (AC drive power ≤55kW) 0.1A~P1-03 (AC drive power >55kW)	

The parameters in P1-06~P1-10 are asynchronous motor parameters. These parameters are unavailable on the motor nameplate and are obtained by means of motor auto-tuning. Only P1-06 to P1-08 can be obtained through static motor auto-tuning. Through complete motor auto-tuning, encoder phase sequence and current loop PI can be obtained besides the parameters in P1-06 to H 1-10.

Each time "Rated motor power" (P1-01) or "Rated motor voltage" (P1-02) is changed, the AC drive automatically restores values of P1-06 to P1-10 to the parameter setting for the common standard Y series asynchronous motor.

If it is impossible to perform motor auto-tuning onsite, manually input the values of these parameters according to data provided by the motor manufacturer.

P1-16	Stator resistance (synchronous motor)	Default	Model dependent
	Setting range	0.001Ω~65.535Ω (AC drive power ≤55kW) 0.0001Ω~6.5535Ω (AC drive power >55kW)	
P1-17	Shaft D inductance (synchronous motor)	Default	Model dependent
	Setting range	0.01mH~655.35mH (AC drive power ≤55kW) 0.001mH~65.535mH (AC drive power >55kW)	
P1-18	Shaft Q inductance (synchronous motor)	Default	Model dependent
	Setting range	0.01mH~655.35mH (AC drive power ≤55kW )	
P1-20	Back EMF (synchronous motor)	Default	Model dependent
	Setting range	0.1V~6553.5V	

P1-16 to H-20 are synchronous motor parameters. These parameters are unavailable on the nameplate of most synchronous motors and can be obtained by means of "Synchronous motor no-load auto-tuning". Because with "Synchronous motor no-load auto-tuning", the VFD can obtain four parameters of P1-16、P1-17、P1-18、P1-19. Through "Synchronous motor with-load auto-tuning", only the encoder phase sequence and installation angle can be obtained.

Each time "Rated motor power" (P1-01) or "Rated motor voltage" (P1-02) is changed, the AC drive automatically modifies the values of F1-16 to F1-20.

You can also directly set the parameters based on the data provided by the synchronous motor manufacturer.

P1-27	Encoder pulses per revolution	Default	1024
	Setting range	1~65535	

This parameter is used to set the pulses per revolution (PPR) of ABZ or UVW incremental encoder.

In the speed sensor vector control mode, the motor cannot run properly if this parameter is (Encoder pulses per revolution )set incorrectly.

P1-28	Encoder pulses per revolution		Default	0
	Setting range	0	ABZ incremental encoder	

The CM540 supports multiple types of encoder. Different PG cards are required for different types of encoder. Select the appropriate PG card for the encoder used.

After installation of the PG card is complete, set this parameter properly based on the actual condition. Otherwise, the AC drive cannot run properly.

P1-30	A/B phase sequence of ABZ incremental encoder		Default	0
	Setting range	0	Forward	
		1	Reserve	

This parameter is valid only for ABZ incremental encoder (P1-28 = 0) and is used to set the A/B phase sequence of the ABZ incremental encoder.

It is valid for both asynchronous motor and synchronous motor. The A/B phase sequence can be obtained through "Asynchronous motor complete auto-tuning" or "Synchronous motor no-load auto-tuning".

P1-31	Encoder installation angle	Default	0.0°
	Setting range	0.0°~359.9°	

This parameter is applicable only to synchronous motor. It is valid for ABZ incremental encoder, UVW incremental encoder, resolver and wire-saving UVW encoder, but invalid for SIN/COS encoder.

It can be obtained through synchronous motor no-load auto-tuning or with-load auto-tuning. The parameter is very important for the synchronous motor, after installation of the synchronous motor is complete, the value of this parameter must be obtained by motor auto-tuning. Otherwise, the motor cannot run properly.

P1-32、P1-33、P1-34 reserved



P1-36	Speed feedback PG wire-break fault detection time	Default	0.0s
	Setting range	0.0s:No action 0.1s~10.0s	

This parameter is used to set the time that a wire-break fault lasts. If it is set to 0.0s, the AC drive does not detect the encoder wire-break fault. If the duration of the encoder wire-break fault detected by the AC drive exceeds the time set in this parameter(P1-36), the AC drive reports Err20.

P1-37	Auto-tuning selection	Default	0
	Setting range	0	No auto-tuning
		1	Asynchronous motor static auto-tuning
		2	Asynchronous motor complete auto-tuning
		11	Synchronous motor with-load auto-tuning
		12	Synchronous motor no-load auto-tuning

0: No auto-tuning, Auto-tuning is prohibited.

1: Asynchronous motor static auto-tuning: It is applicable to scenarios where complete auto-tuning cannot be performed because the asynchronous motor cannot be disconnected from the load. Before performing static auto-tuning, properly set the motor type and motor nameplate parameters of P1-00 to P1-05 first. The AC drive will obtain parameters of P1-06 to P1-08 by static auto-tuning.

Action Description: Set this parameter to 1, and press the Key RRUNUN . Then, the AC drive starts static auto-tuning.

2: Asynchronous motor complete auto-tuning.

To perform this type of auto-tuning, ensure that the motor is disconnected from the load. During the process of complete auto-tuning, the AC drive performs static auto-tuning first and then accelerates to 80% of the rated motor frequency within the acceleration time set in P5-17. The AC drive keeps running for a certain period and then decelerates to stop within deceleration time set in P5-18.

Before performing complete auto-tuning, properly set the motor type, motor nameplate parameters of P1-00 to P1-05, "Encoder type" (P1-28) and "Encoder pulses per revolution" (P1-27) first.

The AC drive will obtain motor parameters of P1-06 to P1-10, "A/B phase sequence of ABZ incremental encoder" (P1-30) and vector control current loop PI parameters of P2-13 to P2-16 by complete auto-tuning.

Action description: Set this parameter to 2, and press RUN. Then, the AC drive starts complete auto-tuning.

11: Synchronous motor with-load auto-tuning: It is applicable to scenarios where the synchronous motor cannot be disconnected from the load. In this condition the motor has to be with-load auto-tuning. The motor is not running in this process. Before performing with-load auto-tuning, properly set the motor type and motor nameplate parameters of F1-00 to F1-05 first. By with-load auto-tuning, the AC drive obtains the initial position angle of the synchronous motor, which is a necessary prerequisite of the motor's normal running.

Before the first use of the synchronous motor after installation, motor auto-tuning must be performed.

Action Description: Set this parameter to 11, and press Run. Then, the AC drive starts with-load auto-tuning.

12: Synchronous motor no-load auto-tuning: If the synchronous motor can be disconnected from the load, no-load auto-tuning is recommended, which will achieve better running performance compared with with-load auto-tuning.

During the process of no-load auto-tuning, the AC drive performs with-load auto-tuning first and then accelerates to 80% of the rated motor frequency within the acceleration time set in P5-17. The AC drive keeps running for a certain period and then decelerates to stop within the deceleration time set in P5-18. But Note that P5-08 must set non-zero value, or the identification can not be done normally.

Before performing no-load auto-tuning, properly set the motor type, motor nameplate parameters of P1-00 to P1-05, "Encoder type" (P1-28) and "Encoder

pulses per revolution" (P1-27) and "Number of pole pairs of resolver" P1-34、P1-35 first.

The AC drive will obtain motor parameters of F1-16 to P1-20, encoder related parameters of P1-30 to P1-33 and vector control current loop PI parameters of P2-13 to P2-16 by Synchronous motor no-load auto-tuning

Action description : Set this parameter to 11 and press the Key RUN, Then, the AC drive starts no-load auto-tuning.

Note: Motor auto-tuning can be performed only in operation panel mode. Motor auto-tuning cannot be performed only in operation panel mode.

### Group P2 Vector Control Parameters

Group H2 is valid for vector control, and invalid for V/F control.

P2-00	Speed loop proportional gain1	Default	30
	Setting range	1~100	
P2-01	Speed loop integral time 1	Default	0.50s
	Setting range	0.01s~10.00s	
P2-02	Switchover frequency 1	Default	5.00Hz
	Setting range	0.00~P2-05	
P2-03	Speed loop proportional gain 2	Default	15
	Setting range	0~100	
P2-04	Speed loop integral time 2	Default	1.00s
	Setting range	0.01s~10.00s	
P2-05	Switchover frequency 2	Default	10.00Hz
	Setting range	P2-02~maximum output frequency	

Speed loop PI parameters vary with running frequencies of the AC drive.

If the running frequency is less than or equal to "Switchover frequency 1" (P2-02), the speed loop PI parameters are P2-00 and H 2-01.

If the running frequency is equal to or greater than "Switchover frequency 2" (P2-05), the speed loop PI parameters are P2-03 and P2-04. If the running frequency is between F2-02 and F2-05, the speed loop PI parameters are obtained from the linear switchover between the two groups of PI parameters, as Figure 6-2:

The speed dynamic response characteristics in vector control can be adjusted by setting the proportional gain and integral time of the speed regulator.

To achieve a faster system response, increase the proportional gain and reduce the integral time. Be aware that this may lead to system oscillation.

The recommended adjustment method is as follows:

If the factory setting cannot meet the requirements, make proper adjustment. Increase the proportional gain first to ensure that the system does not oscillate, and then reduce the integral time to ensure that the system has quick response and small overshoot.

Note: Improper PI parameter setting may cause too large speed overshoot, and overvoltage fault may even occur when the overshoot drops.

P2-06	Vector control slip gain	Default	100%
	Setting range	50%~200%	

For speed sensor-less vector control, it is used to adjust speed stability accuracy of the motor. When the motor with load runs at a very low speed, increase the value of this parameter; when the motor with load runs at a very large speed, decrease the value of this parameter.

For speed sensor vector control, it is used to adjust the output current of the AC drive with same load.

P2-07	Time constant of speed loop filter	Default	0.000s
	Setting	0.000s~0.100s	

In the vector control mode, the output of the speed loop regulator is torque current

reference. This parameter is used to filter the torque references. It need not be adjusted generally and can be increased in the case of large speed fluctuation. In the case of motoroscillation, decrease the value of this parameter properly.

If the value of this parameter is small, the output torque of the AC drive may fluctuategreatly, but the response is quick.

P2-08	Vector control over-excitation gain	Default	64
	Setting range		0~200

During deceleration of the AC drive, over-excitation control can restrain rise of the bus voltage to avoid the overvoltage fault. The larger the over-excitation gain is, the better the restraining effect is.

Increase the over-excitation gain if the AC drive is liable to overvoltage error during deceleration. Too large over-excitation gain, however, may lead to an increase in output current. Therefore, set this parameter to a proper value in actual applications.

Set the over-excitation gain to 0 in applications of small inertia (the bus voltage will not rise during deceleration) or where there is a braking resistor.

P2-09	Torque upper limit source in speed control mode		Default	0
	Setting	0	P2-10	
		1	AI1	
		2	AI2	
		3	AI3	
		4	HDI setting	
		5	Communication setting	
P2-10	Digital setting of torque upper limit in speed control mode		Default	150.0%
	Setting range		0.0%~200.0%	

In the speed control mode, the maximum output torque of the AC drive is restricted by P2-09.

If the torque upper limit is analog, pulse or communication setting, 100% of the setting corresponds to the value of P2-10, and 100% of the value of P2-10 corresponds to the AC drive rated torque.

P2-13	Excitation adjustment proportional gain	Default	2000
	Setting range	0~20000	
P2-14	Excitation adjustment integral gain	Default	1300
	Setting range	0~20000	
P2-15	Torque adjustment proportional gain	Default	2000
	Setting range	0~20000	
P2-16	Torque adjustment integral gain	Default	1300
	Setting range	0~20000	

These are current loop PI parameters for vector control. These parameters are automatically obtained through "Asynchronous motor complete auto-tuning" or "Synchronous motor no-load auto-tuning", and need not be modified.

Note that the dimension of the current loop integral regulator is integral gain rather than integral time. Too large current loop PI gain may lead to oscillation of the entire control loop. Therefore, when current oscillation or torque fluctuation is great, manually decrease the proportional gain or integral gain here.

P2-18	Field weakening mode of synchronous motor	Default	0
	Setting range	0	No field weakening
		1	Direct calculation
		2	Direct calculation
P2-19	Field weakening depth of synchronous motor	Default	100%
	Setting range	50%~500%	
P2-20	Maximum field weakening current	Default	50%

	Setting range	1%~300%	
P2-21	Field weakening automatic adjustment gain	Default	100%
	Setting range	10%~500%	
P2-22	Field weakening integral multiple	Default	2
	Setting range	2~10	

These parameters are used to set field weakening control for the synchronous motor.

If P2-18 is set to 0, field weakening control on the synchronous motor is disabled. In this case, the maximum rotational speed is related to the AC drive bus voltage. If the motor's maximum rotational speed cannot meet the requirements, enable the field weakening function to increase the speed.

The CM540 provides two field weakening modes: direct calculation and automatic adjustment. In direct calculation mode, directly calculate the demagnetized current and manually adjust the demagnetized current by means of P2-19. The smaller the demagnetized current is, the smaller the total output current is. However, the desired field weakening effect may not be achieved.

In automatic adjustment mode, the best demagnetized current is selected automatically. This may influence the system dynamic performance or cause instability.

The adjustment speed of the field weakening current can be changed by modifying the values of P2-21 and P2-22. A very quick adjustment may cause instability. Therefore, generally do not modify them manually.

### Group P3 V/F Control Parameters

Group H3 is valid only for V/F control.

The V/F control mode is applicable to low load applications (fan or pump) or applications where one AC drive operates multiple motors or there is a large difference between the AC drive power and the motor power.

P3-00	V/F curve setting		Default	0
	Setting range	0	Linear V/F	
		1	Multi-point V/F	
		2	Square V/F	

		3	1.2-power V/F
		4	1.4-power V/F
		6	1.6-power V/F
		8	1.8-power V/F
		9	Power
		10	VF complete separation
		11	VF half separation

0: Linear V/F. It is applicable to common constant torque load.

1: It is applicable to special load such as dehydrator and centrifuge. Any such V/F curve can be obtained by setting parameters of P3-03 to P3-08

2: Square V/F. It is applicable to centrifugal loads such as fan and pump.

3~8: V/F curve between linear V/F and square V/F.

10: V/F complete separation

In this mode, the output frequency and output voltage of the AC drive are independent. The output frequency is determined by the frequency source, and the output voltage is determined by "Voltage source for V/F separation" (P3-13). It is applicable to induction heating, inverse power supply and torque motor control.

11: V/F half separation

In this mode, V and F are proportional and the proportional relationship can be set in P3-13. The relationship between V and F are also related to the rated motor voltage and rated motor frequency in Group F1.

Assume that the voltage source input is X (0 to 100%), the relationship between V and F is:  $V/F = 2 * X * (\text{Rated motor voltage}) / (\text{Rated motor frequency})$ .

P3-01	Torque boost	Default	Model dependent
	Setting range	0.0%~30%	



P3-02	Cut-off frequency of torque boost	Default	50.00Hz
	Setting range	0.00Hz~maximum output frequency	

To compensate the low frequency torque characteristics of V/F control, you can boost the output voltage of the AC drive at low frequency by modifying P3-01. If the torque boost is set to too large, the motor may overheat, and the AC drive may suffer over-current.

If the load is large and the motor startup torque is insufficient, increase the value of P3-01. If the load is small, decrease the value of P3-01. If it is set to 0.0, the AC drive performs automatic torque boost. In this case, the AC drive automatically calculates the torque boost value based on motor parameters including the stator resistance.

P3-02 specifies the frequency under which torque boost is valid. Torque boost becomes invalid when this frequency is exceeded, as shown in the following figure 6-3.

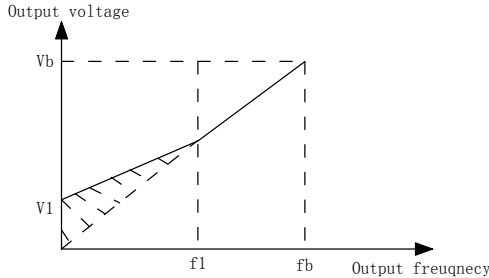

A11: Voltage of manual torque boost

Vb: Maximum output voltage

f1: Cutoff frequency of manual torque boost

fb: Rated running frequency

Figure 6-3 Manual torque boost

P3-03	Multi-point V/F frequency F1	Default	0.00Hz
	Setting range	0.00Hz~P3-05	
P3-04	Multi-point V/F voltage A11	Default	0.0%
	Setting range	0.0%~100.0%	

P3-05	Multi-point V/F frequency F2	Default	0.00Hz
	Setting range	P3-03~P3-07	
P3-06	Multi-point V/F voltage AI2	Default	0.0%
	Setting range	0.0%~100.0%	
P3-07	Multi-point V/F frequency F3	Default	0.00Hz
	Setting range	P3-05~to rated motor frequency(P1-04) Note: The rated frequencies of motors 2 H2-04	
P3-08	Multi-point V/F frequency AI3	Default	0.0%
	Setting range	0.0%~100.0%	

P3-03~P3-08 these six parameters are used to define the multi-point V/F curve.

The multi-point V/F curve is set based on the motor's load characteristic. The relationship between voltages and frequencies is:  $A11 < A12 < A13$  ,  $F1 < F2 < F3$ .

Figure 6-4Setting of multi-point V/F curve

At low frequency, higher voltage may cause overheat or even burnt out of the motor and over-current stall or over-current protection of the AC drive.

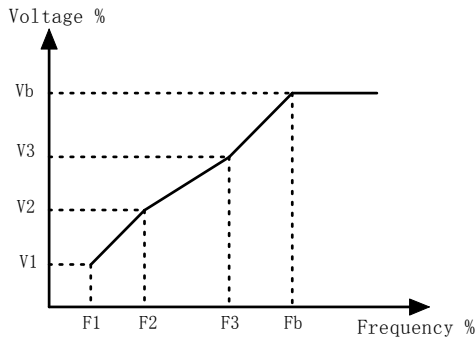

1-AI3: 1st, 2nd and 3rd voltage percentages of multi -point V/F

F1-F3: 1st, 2nd and 3rd frequency percentages of multi -point V/F

Vb: Rated motor voltage      Fb: Rated motor running frequency

Figure 6-4 the multi-point V/F curve.

P3-09	V/F slip compensation gain	Default	0.0%
	Setting range	0%~200.0%	

This parameter is valid only for the asynchronous motor.

It can compensate the rotational speed slip of the asynchronous motor when the load of the motor increases, stabilizing the motor speed in case of load change. If this parameter is set to 100%, it indicates that the compensation when the motor bears rated load is the rated motor slip. The rated motor slip is automatically obtained by the AC drive through calculation based on the rated motor frequency and rated motor rotational speed in group H1.

Generally, if the motor rotational speed is different from the target speed, slightly adjust this parameter.

P3-10	V/F over-excitation gain	Default	64
	Setting range	0~200	

During deceleration of the AC drive, over-excitation can restrain rise of the bus voltage, preventing the overvoltage fault. The larger the over-excitation is, the better the restraining result is.

Increase the over-excitation gain if the AC drive is liable to overvoltage error during deceleration. However, too large over-excitation gain may lead to an increase in the output current. Set P3-09 to a proper value in actual applications.

Set the over-excitation gain to 0 in the applications where the inertia is small and the bus voltage will not rise during motor deceleration or where there is a braking resistor.

P3-11	Set the over-excitation gain to 0 in the applications where the inertia is small and the bus voltage will not rise during motor deceleration or where there is a braking resistor.	Default	Model dependent
	Setting range	0~100	

Set this parameter to a value as small as possible in the prerequisite of efficient

oscillation suppression to avoid influence on V/F control. Set this parameter to 0 if the motor has no oscillation. Increase the value properly only when the motor has obvious oscillation. The larger the value is, the better the oscillation suppression result will be.

When the oscillation suppression function is enabled, the rated motor current and no load current must be correct. Otherwise, the V/F oscillation suppression effect will not be satisfactory.

P3-13	Voltage source for V/F separation	Default	0
	Setting range	0	Digital setting ( P3-14 )
		1	A11
		2	A12
		3	A13
		4	HDI Digital setting(DI6)
		5	Digital setting
		6	Simple PLC
		7	PID
		8	Communication setting
		100.0% corresponds to the rated motor voltage(P1-02、 H2-02)	
P3-14	Voltage digital setting for V/F separation	Default	0V
	Setting range	0V~rated motor voltage	

V/F separation is generally applicable to scenarios such as induction heating, inverse power supply and motor torque control.

If V/F separated control is enabled, the output voltage can be set in P3-14 or by means of analog, multi-reference, simple PLC, PID or communication. If you set the output voltage by means of non-digital setting, 100% of the setting

corresponds to the rated motor voltage. If a negative percentage is set, its absolute value is used as the effective value.

#### 0: Digital setting ( P3-14 )

The output voltage is set directly in P3-14.

#### 1.AI1 2.AI2 3.AI3

The output voltage is set by AI terminals.

4.The output voltage is set by pulses of the terminal DI6. Pulse setting specification: voltage range 9–30 V, frequency range 0–100 kHz

5.Multi-reference :If the voltage source is multi-reference, parameters in group H4 and FC must be set to determine the corresponding relationship between setting signal and setting voltage.

#### 6.Simple PLC

If the voltage source is simple PLC mode, parameters in group FC must be set to determine the setting output voltage.

#### 7.PID

The output voltage is generated based on PID closed loop. For details, see the description of PID in group HA.

#### 8.Communication setting

The output voltage is set by the host computer by means of communication.

The voltage source for V/F separation is set 1~8, 0~100% of the setting in each mode corresponds to the rated motor voltage.

P3-15	Voltage rise time of V/F separation	Default	0.0s
	Setting range	0.0s~1000.0s	

V/F separation rising time is the time output voltage from 0V to the rated motor voltage. Please refer to Figure 6-5:

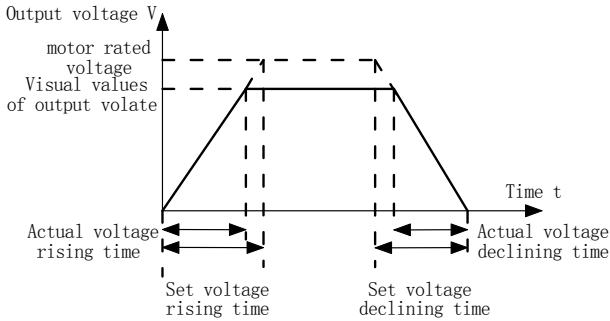

Figure 6-5 Voltage of V/F separation

### Group P4 Input Terminals S

The CM540 provides five DI (digital input) terminals (DI6 can be used for high-speed pulse input) and two analog input (AI) terminals. The optional input and output extension card provides more input and output terminals if the system needs.

The multi- function input and output extensive card has 3 The multi- function digital input terminals(S6~S8), and 1 analog input terminal(AI3).

P4-00	DI1 terminal function selection	Default	1(Forward RUN)
P4-01	DI2 terminal function selection	Default	4(Forward JOG)
P4-02	DI3 terminal function selection	Default	9(Fault reset)
P4-03	DI4 terminal function selection	Default	12(Multi-reference terminal 1)
P4-04	DI5 terminal function selection	Default	13(Multi-reference terminal 2)
P4-05	DI6 terminal function selection	Default	0

The following table lists the functions available for the DI terminals:

Setting value	Function	Description
0	No function	Set 0 for reserved terminals to avoid malfunction
1	Forward RUN(FWD)	The terminal is used to control forward or reverse RUN of the AC drive.
2	Reverse RUN(REV)	

3	Three-line control	The terminal determines three-line control of the AC drive. For details, see the description of P4-11.
4	Forward JOG(FJOG)	FJOG indicates forward JOG running, while RJOG indicates reverse JOG running. The JOG frequency, acceleration time and deceleration time are described respectively in P8-00, P8-01 and P8-02.
5	Reverse JOG(RJOG)	
6	Terminal UP	If the frequency is determined by external terminals, the terminals with the two functions are used as increment and decrement commands for frequency modification. When the frequency source is digital setting, they are reused to adjust the frequency.
7	Terminal DOWN	
8	Coast to stop	The AC drive blocks its output, the motor coasts to Rest and is not controlled by the AC drive. It is The same as coast to stop described in P6-10.
9	Fault reset(RESET)	The terminal is used for fault reset function, the same as the function of RESET key on the operation panel.
10	RUN pause	The AC drive decelerates to stop, but the running parameters are all memorized, such as PLC, swing frequency and PID parameters. After this function is disabled, the AC drive resumes its status before stop.
11	Normally open (NO) Input of external fault	If this terminal becomes ON, the AC drive reports E15 and performs the fault protection action. For More details, see the description of P9-47.
1 2	Multi-reference terminal1	The setting of 16 speeds or 16 other references can be implemented through combinations of 16 states of these four terminals. The detail information please refer to the attached table 1.
1 3	Multi-reference terminal2	
1 4	Multi-reference terminal3	
1 5	Multi-reference terminal4	
16	acceleration/ deceleration time selection terminal 1	Totally four groups of acceleration/deceleration time can be selected through combinations of four

17	acceleration/ deceleration time selection terminal 2	states of these two terminals. The detail information please refer to the attached table 2.
18	Frequency source switchover	The terminal is used to perform switchover between Two frequency sources according to the setting in P5-07.
19	UP/DOW setting clear (terminal、operation panel )	If the frequency source is digital setting, the terminal is used to clear the modification by using the UP/DOWN function or the increment/decrement key on the operation panel, returning the set frequency to the Value of P5-08.
20	Command source switchover terminal 1	If the command source is set to terminal control(P5-02 = 1 ), this terminal is used to perform switchover between terminal control and operation panel control. If the command source is set to communication control (P5-02 = 2), this terminal is used to perform switchover between communication control and operation panel control.
21	Acceleration/Deceleration prohibited	It enables the AC drive to maintain the current frequency output without being affected by external signals (except the STOP command).
22	PID pause	PID is invalid temporarily. The AC drive maintains the current frequency output without supporting PID adjustment of frequency source.
23	PLC status reset	The terminal is used to restore the original status Of PLC control for the AC drive when PLC control is started again after a pause.
24	Swing pause	The AC drive outputs the central frequency, and the swing frequency function pauses.
25	Counter input	The input terminal is used to count pulses.
26	Counter reset	This terminal is used to clear the counter status.
27	Length count input	This terminal is used to count the length
28	Length reset	This terminal is used to clear the length.



29	Torque control prohibited	The AC drive is prohibited from torque control and enters the speed control mode
30	Pulse input (enabled only for DI6)	DI6 is used for pulse input.
31	Reserved	Reserved
32	Immediate DC braking	After this terminal becomes ON, the AC drive directly switches over to the DC braking state.
33	Normally closed(NC) input of external fault	After this terminal becomes ON, the AC drive reports E015 and stops.
34	Freq uenmodification forbidden	After this terminal becomes ON, the AC drive does not respond to any frequency modification.
35	Reverse PID action direction	After this terminal becomes ON, the PID action Direction is reversed to the direction set inPA-03.
36	External STOP terminal 1	In operation panel mode, this terminal can be used to stop the AC drive, equivalent to the function of the STOP key on the operation panel.
37	Command sourceswitchover terminal 2	It is used to perform switchover between terminal control and communication control. If the commandsource is terminal control, the system will switch over to communication control after this terminal becomes ON.
38	PID integral pause	After this terminal becomes ON, the integral adjustment function pauses. However, the proportional and differentiation adjustment functions are still valid.
39	Switchover between main frequency source A and preset frequency	After this terminal becomes ON, the frequency source X is replaced by the preset frequency set in P5-08.
40	Switchover between auxiliary frequency B and preset frequency	After this terminal is enabled, the frequency source Y is replaced by the preset frequency set in P5-08.
41	Motor selection terminal 1	Switchover among the 2 groups of motor parameters can be implemented through the 2

42	Reserved	
43	PID parameter switchover	If the PID parameters switchover performed by means of DI terminal (PA-1 8 = 1 ), the PID parameters are PA-05 to PA-07 when the terminal becomes OFF; the PID parameters are PA-1 5 to PA-1 7 when this terminal becomes ON.
44	User-defied fault 1	If these two terminals become ON, the AC drive reports Err27 and Err28 respectively, and performs fault protection actions based on the setting in P9-49.
45	User-defied fault 2	
46	Speed control/Torque control switchover	This terminal enables the AC drive to switch over between speed control and torque control. When this terminal becomes OFF, the AC drive runs in the mode set in H0-00. When this terminal becomes ON, the AC drive switches over to the other control mode.
47	Emergency stop	When this terminal becomes ON, the AC drive stops within the shortest time. During the stop process, the current remains at the set current upper limit. This function is used to satisfy the requirement of stopping the AC drive in emergency state.
48	External STOP terminal 2	In any control mode (operation panel, terminal or communication), it can be used to make the AC drive decelerate to stop. In this case, the deceleration time is deceleration time 4.
49	Deceleration DC braking	When this terminal becomes ON, the AC drive decelerates to the initial frequency of stop DC braking and then switches over to DC braking state.
50	Clear the current running time	When this terminal becomes ON, the AC drive's current running time is cleared. This function must be supported by P8-42 and P8-53.

### Multi-reference function description

The four multi-reference terminals have 16 state combinations, corresponding to 16 reference values, as listed in the following table:

K4	K3	K2	K1	Reference Setting	Corresponding Parameter
----	----	----	----	-------------------	-------------------------

OFF	OFF	OFF	OFF	Reference 0	PC-00
OFF	OFF	OFF	ON	Reference 1	PC-01
OFF	OFF	ON	OFF	Reference 2	PC-02
OFF	OFF	ON	ON	Reference 3	PC-03
OFF	ON	OFF	OFF	Reference 4	PC-04
OFF	ON	OFF	ON	Reference 5	PC-05
OFF	ON	ON	OFF	Reference 6	PC-06
OFF	ON	ON	ON	Reference 7	PC-07
ON	OFF	OFF	OFF	Reference 8	PC-08
ON	OFF	OFF	ON	Reference 9	PC-09
ON	OFF	ON	OFF	Reference 10	PC-10
ON	OFF	ON	ON	Reference 11	PC-11
ON	ON	OFF	OFF	Reference 12	PC-12
ON	ON	OFF	ON	Reference 13	PC-13
ON	ON	ON	OFF	Reference 14	PC-14
ON	ON	ON	ON	Reference 15	PC-15

If the frequency source is multi-reference, the value 100% of PC-00 to PC-15 corresponds to the value of P5-10 (Maximum frequency).

Besides the multi-speed function, the multi-reference can be also used as the PID setting source or the voltage source for V/F separation, satisfying the requirement on switchover of different setting values.

Acceleration/Deceleration time selection terminal function description as below:

Terminal 2	Terminal 1	Acceleration/Deceleration Time Selection	responding Parameters
OFF	OFF	Acceleration time 1	P5-17、P5-18
OFF	ON	Acceleration time 2	P8-03、P8-04
ON	OFF	Acceleration time 3	P8-05、P8-06
ON	ON	Acceleration time 4	P8-07、P8-08

Motor selection terminal function as below:

Motor Terminal Selected 1	Acceleration Time	Acceleration Time
OFF	Motor1	Group H1、 H2
ON	Motor2	Group C2

P4-10	DI Filter Time	Default	0.010s
	Setting range	0.000s~1.000s	

It is used to set the software filter time of DI terminal status. If DI terminals are liable to interference and may cause malfunction, increase the value of this parameter to enhance the anti-interference capability. However, increase of DI filter time will reduce the response of DI terminals.

P4-11	Terminal command mode		Default	0
	Setting range	0	Two-line mode 1	
		1	Two-line mode 2	
		2	Three-line mode 1	
		3	Three-line mode 2	

This parameter is used to set the mode in which the AC drive is controlled in four ways by external terminals.

Note: For convenience of illustration, the following uses S1, S2 and S3 among S1 to S8 as an example, with allocating functions of S1, S2 and S3 by setting P4-00 to P4-02.

About the detailed function definition, Please referring to the P4-00~P4-07 setting range.

0:Two-line mode

1:It is the most commonly used two-line mode, in which the forward/reverse rotation of the motor is decided byS1 and S2. The parameters are set as below:

Function Code	Parameter Name	Setting Value	Function Description
---------------	----------------	---------------	----------------------

P4-11	Terminal command mode	0	Two-line 1
P4-00	DI1 function selection	1	Two-line (FWD)
P4-01	DI2 function selection	2	Reverse RUN (REV)

K1	K2	Run command
1	0	Forward Run
0	1	Reverse RUN
1	1	Stop
0	0	Stop

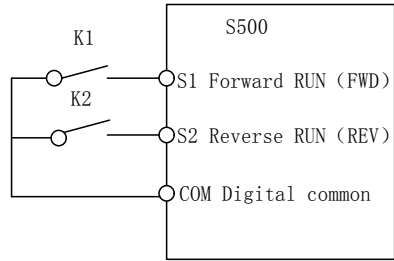

Figure 6-6 Two-line mode

As shown in the preceding figure, when only K1 is ON, the AC drive instructs forward rotation. When only K2 is ON, the AC drive instructs reverse rotation. When K1 and K2 are ON or OFF simultaneously, the AC drive stops.

1:Two-line mode 2: In this mode, DI1 is RUN enabled terminal, and DI2 determines the running direction. The parameters are set as below:

Function Code	Parameter Name	Setting Value	Function Description
P4-11	Terminal command mode	1	Two-line 2
P4-00	DI1 function selection	1	RUN enabled
P4-01	DI2 function selection	2	Forward or reverse direction

K1	K2	Run command
1	0	Forward Run
1	1	Reverse RUN
0	0	Stop
0	1	Stop

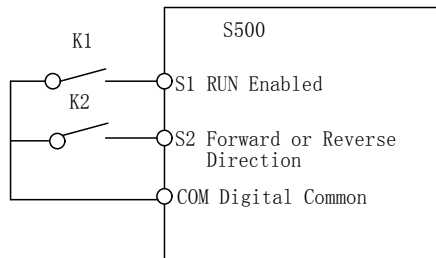

Figure 6-7 Two-line 2 mode

As shown in the preceding figure, if K1 is ON, the AC drive instructs forward rotation when K2 is OFF, and instructs reverse rotation when K2 is ON. If K1 is OFF, the AC drive stops.

2:Three-line mode 1:In this mode, DI3 is RUN enabled terminal, and the direction is decided by DI1 and DI2. The parameters are set as below:

Function Code	Parameter Name	Value	Function Description
P4-11	Terminal command mode	2	Three-line1
P4-00	DI1 function selection	1	Forward RUN (FWD)
P4-01	DI2 function selection	2	Reverse RUN (REV)
P4-02	DI3 function selection	3	Three-line control

As shown in the preceding figure, if SB1 is ON, the AC drive instructs forward rotation when SB2 is pressed to be ON and instructs reverse rotation when SB3 is pressed to be ON. The AC drive stops immediately after SB1 becomes OFF. During normal startup and running, SB1 must remain ON. The AC drive's running state is determined by the final actions on SB1, SB2 and SB3.

3:Three-line mode 2:In this mode, S3 is RUN enabled terminal. The RUN command is given by S1 and the direction is decided by S2. The parameters are set as below:

Function Code	Parameter name	Setting value	Function description
P4-11	Terminal command mode	3	Three-line2
P4-00	DI1 function selection	1	RUN enabled
P4-01	DI2 function selection	2	RUN enabled
P4-02	DI3 function selection	3	Three-line control

K	Running direction
0	Forward
1	Reverse

Figure 6-9 Setting of three-line mode 2

As shown in the preceding figure, if SB1 is ON, the AC drive starts running when SB2 is pressed to be ON; the AC drive instructs forward rotation when K is OFF and instructs reverse rotation when K is ON. The AC drive stops immediately after SB1 becomes OFF. During normal startup and running, SB1 must remain ON. The AC drive's running state is determined by the final actions of SB1, SB2 and K.

P4-12	Terminal UP/DOWN rate	Default	1.00Hz/s
	Setting range	0.01Hz/s~65.535Hz/s	

It is used to adjust the rate of change of frequency when the frequency is adjusted by means of terminal UP/DOWN.

If P0-22 (Frequency reference resolution) is 2, the setting range is 0.001–65.535 Hz/s. If P0-22 (Frequency reference resolution) is 1, the setting range is 0.01–655.35 Hz/s.

P4-13	AI curve 1 minimum input	Default	0.00V
	Setting range	0.00V~P4-15	
P4-14	Corresponding setting of AI1 curve 1 minimum input	Default	0.0%
	Setting range	-100.00%~100.0%	
P4-15	AI curve 1 maximum input	Default	10.00V
	Setting range	P4-13~10.00V	
P4-16	Corresponding setting of AI curve 1 maximum input	Default	100.0%

	Setting range	-100.00%~100.0%	
P4-17	AI1 filter time	Default	0.10s
	Setting range	0.00s~10.00s	

These parameters are used to define the relationship between the analog input voltage and the corresponding setting. When the analog input voltage exceeds the maximum value (P4-15), the maximum value is used. When the analog input voltage is less than the minimum value (P4-13), the value set in P4-34 (Setting for AI less than minimum input) is used.

When the analog input is current input, 1 mA current corresponds to 0.5 V voltage.

P4-17 (AI1 filter time) is used to set the software filter time of AI1. If the analog input is liable to interference, increase the value of this parameter to stabilize the detected analog input. However, increase of the AI filter time will slow the response of analog detection. Set this parameter properly based on actual conditions.

In different applications, 100% of analog input corresponds to different nominal values. For details, refer to the description of different applications.

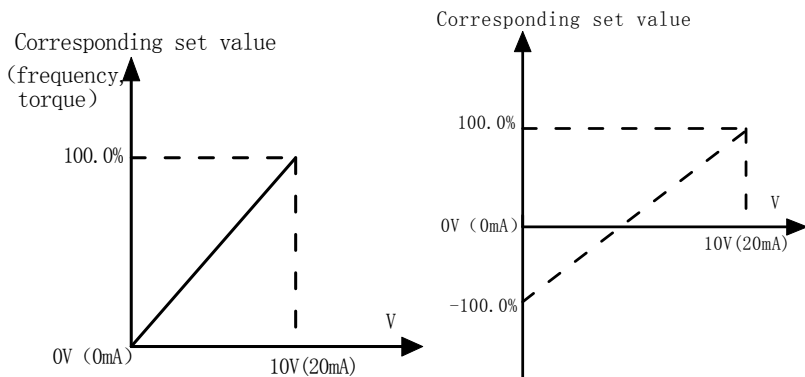

Figure 6-10 Corresponding relationship between analog input and set values

Two typical setting examples are shown in the following figure:



P4-18	AI curve 2 minimum input	Default	0.00V
	Setting range	0.00V~P4-20	
P4-19	Corresponding setting of AI curve 2 minimum input	Default	0.0%
	Setting range	-100.00%~100.0%	
P4-20	AI curve 2 maximum input	Default	10.00V
	Setting range	P4-18~10.00V	
P4-21	Corresponding setting of AI curve 2 maximum input	Default	100.0%
	Setting range	-100.00%~100.0%	
P4-22	AI2 filter time	Default	0.10s
	Setting range	0.00s~10.00s	

The function method of curve2 is similar to curve 1 function.

P4-23	AI curve 3 minimum input	Default	0.00V
	Setting range	0.00s~P4-25	
P4-24	Corresponding setting of AI curve 3 minimum input	Default	0.0%
	Setting range	-100.00%~100.0%	
P4-25	AI curve 3 maximum input	Default	10.00V
	Setting range	P4-23~10.00V	
P4-26	Corresponding setting of AI curve 3 maximum input	Default	100.0%
	Setting range	-100.00%~100.0%	
P4-27	AI3 filter time	Default	0.10s
	Setting range	0.00s~10.00s	

The function method of curve3 is similar to curve 1 function.

P4-28	HDI minimum input	Default	0.00kHz
-------	-------------------	---------	---------

	Setting range	0.00kHz~P4-30	
P4-29	HDI corresponding setting of pulse minimum input	Default	0.0%
	Setting range	-100.00%~100.0%	
P4-30	HDI maximum input	Default	50.00kHz
	Setting range	P4-28~50.00kHz	
P4-31	HDI corresponding setting of pulse maximum input	Default	100.0%
	Setting range	-100.00%~100.0%	
P4-32	HDI filter time	Default	0.10s
	Setting range	0.00s~10.00s	

These parameters are used to set the relationship between S5 pulse input and corresponding settings. The pulses can only be input by S5. The method of setting this function is similar to that of setting curve 1 function.

P4-33	V curve selection		Default	321
	Setting range	curve selection	AI1 curve selection	
		1	Curve 1 ( 2 points , see P4-13~P4-16 )	
		2	Curve 2 ( 2 points , see P4-18~P4-21 )	
		3	Curve 3 ( 2 points , see P4-23~P4-26 )	
		4	Curve 4 ( 4 points , see H6-00~H6-07 )	
		5	curve 5 ( 4 point , see H6-08~H6-15 )	
		Ten's digit	AI2 curve selection ( same as 1~6 )	
		Hundred's digit	AI3 curve selection ( same as 1~6 )	

The unit's digit, ten's digit and hundred's digit of this parameter are respectively used to select the corresponding curve of AI1, AI2 and AI3. Any of the five curves can be selected for AI1, AI2 and AI3.

Curve 1, curve 2 and curve 3 are all 2-point curves, set in group H4. Curve 4 and

curve 5 are both 4-point curves, set in group A8.

The CM540 provides two AI terminals as standard. AI3 is provided by an optional extension card.

P4-34	Setting for AI less than minimum input		Default	000
	Setting range	Unit's digit	Setting for AI1 less than minimum input	
		0	Corresponding to the minimum input setting	
		1	0.0%	
		Ten's digit	AI2 less than minimum input (0~1 , the same as AI1)	
Hundred's digit	AI3 less than minimum input (0~1 , the same as AI1)			

This parameter is used to determine the corresponding setting when the analog input voltage is less than the minimum value. The unit's digit, ten's digit and hundred's digit of this parameter respectively correspond to the setting for AI1, AI2 and AI3.

If the value of a certain digit is 0, when analog input voltage is less than the minimum input, the corresponding setting of the minimum input (P4-14, P4-19, P4-24) is used. If the value of a certain digit is 1, when analog input voltage is less than the minimum input, the corresponding value of this analog input is 0.0%.

P4-35	DI1delay time	Default	0.0s
	Setting range	0.0s~3600.0s	
P4-36	DI2 delay time	Default	0.0s
	Setting range	0.0s~3600.0s	
P4-37	DI3 delay time	Default	0.0s
	Setting range	0.0s~3600.0s	

These parameters are used to set the delay time of the AC drive when the status

of DI terminals changes. Currently, only S1, S2 and S3 support the delay time function.

P4-38	DI valid mode selection 1		Default	00000
	Setting range	Unit's digit	DI1 terminal valid mode setting	
		0	positive logic	
		1	Negative logic	
		Ten's digit	DI2 terminal valid mode setting (0~1 , the same as S1)	
		Hundred's digit	DI3 terminal valid mode setting (0~1 , the same as S1)	
		Thousand's digit	DI4 terminal valid mode setting (0~1 , the same as S1)	
		Ten thousand's digit	DI5 terminal valid mode setting (0~1 , the same as S1)	
P4-39	DI valid mode selection 2		Default	00000
	Setting range	Unit's digit	DI6 terminal valid mode	
		0	positive logic	
		1	Negative logic	
		Ten's digit		
		Hundred's digit		
		Reserved		
		Reserved		

These parameters are used to set the valid mode of DI terminals.

0:Positive logic

Then DI terminal is valid when being connected with COM, and invalid when being disconnected with COM.

1: Negative logic

The DI terminal is invalid when being contacted with COM, and valid when being connected with COM.

## Group P5 Output Terminals

The CM540 provides an analog output (A01) terminal, a relay terminal TA-TB-TC and a SP1 terminal (used for high-speed pulse output or open-collector switch signal output could be selected) as standard. If these output terminals cannot satisfy requirements, use an optional I/O extension card that provides an A02 terminal , 2 relay terminal S ( TA2-TB2-TC2、 TA3-TB3-TC3 ) , a open-collector switch signal output(SP2).

P5-00	SP1 terminal output mode Default		Default	0
	Setting Range	0	Pulse output ( HDO )	
		1	Open-collector output (FM)	

The SP1 terminal is programmable multiplexing terminal. It can be used for high-speed pulse output (HDO), with maximum frequency of 50 kHz. Refer to P5-06 for relevant functions of HDO It can also be used as open collector switch signal output (HDO).

P5-01	open-collector output terminal SP1	Default	0
P5-02	Relay function ( TA-TB-TC )	Default	2
P5-03	Extension card relay 2 function( TA2-TB2-TC2	Default	0

These five parameters are used to select the functions of the five digital output terminals.

DO Functions of output terminals:

Value	Function	Description
0	No output	The terminal has no function.
1	AC drive running	When the AC drive is running and has output Frequency (can be zero), the terminal becomes ON.

2	Fault output (stop)	When the AC drive stops due to a fault, the Terminal becomes ON.
3	Frequency-level detection FDT1 output	Refer to the descriptions of P8-19 and P8-20
4	Frequency reached	Refer to the descriptions of P8-21.
5	Zero-speed running (no output at stop)	If the AC drive runs with the output frequency of 0, the terminal becomes ON. If the AC drive is in the stop state, the terminal becomes OFF.
6	Motor overload pre-warning	The AC drive judges whether the motor load exceeds The overload pre-warning threshold before performing the protection action. If the pre-warning threshold is exceeded, the terminal becomes ON. For motor overload parameters, see the descriptions of P9-00 to P9-02.
7	AC drive overload prewarning	The terminal becomes ON 10s before the AC drive overload protection action is performed.
8	Set count value reached	The terminal becomes ON when the count value Reaches the value set in Pb-08.
9	Designated count value reached	The terminal becomes ON when the count value Reaches the value set in Pb-09.
10	Length reached	The terminal becomes ON when the detected actual length exceeds the value set in Pb-05.
11	PLC cycle complete	When simple PLC completes one cycle, the terminal outputs a pulse signal with width of 250 ms.
12	Accumulative running time reached	If the accumulative running time of the AC drive exceeds the time set in P8-17, the terminal becomes ON.
13	Frequency limited	If the set frequency exceeds the frequency upper limit or lower limit and the output frequency of the AC drive reaches the upper limit or lower limit, the terminal becomes ON.

14	Torque limited	In speed control mode, if the output torque reaches the torque limit, the AC drive enters the stall protection state and meanwhile the terminal becomes ON.
15	Ready for RUN	If the AC drive main circuit and control circuit become stable, and the AC drive detects no fault and is ready for RUN, the terminal becomes ON.
16	AI1>AI2	When the input of AI1 is larger than the input of AI2, the terminal becomes ON.
17	Frequency upper limit reached	If the running frequency reaches the upper limit, The terminal becomes ON.
18	Frequency lower limit reached (no output at stop)	If the running frequency reaches the lower limit, the terminal becomes ON. In the stop state, the terminal becomes OFF.
19	Under voltage state output	If the AC drive is in under voltage state, the terminal becomes ON.
20	Communication setting	Refer to the communication protocol.
21	Reserved	Reserved.
22	Reserved	Reserved.
23	Zero-speed running 2 (having output at stop)	If the output frequency of the AC drive is 0, the terminal becomes ON. In the state of stop, the signal is still ON.
24	Accumulative power on time reached	If the AC drive accumulative power-on time (P7-13) exceeds the value set in P8-16, the terminal becomes ON.
25	Frequency level detection FDT2 output	Refer to the descriptions of P8-28 and P8-29.
26	Frequency 1 reached	Refer to the descriptions of P8-30 and F8-31.
27	Frequency 2 reached	Refer to the descriptions of P8-32 and P8-33.
28	Current 1 reached	Refer to the descriptions of P8-38 and P8-39.
29	Current 2 reached	Refer to the descriptions of P8-40 and P8-41.

30	Timing reached	If the timing function (P8-42) is valid, the terminal becomes ON after the current running time of the AC drive reaches the set time.
31	AI1 input limit exceeded	If AI1 input is larger than the value of P8-46 (AI1 input voltage upper limit) or lower than the value of P8-45 (AI1 input voltage lower limit), the terminal becomes ON.
32	Load becoming 0	If the load becomes 0, the terminal becomes ON.
33	Reverse running	If the AC drive is in the reverse running state, the terminal becomes ON.
34	Zero current state	Refer to the descriptions of P8-28 and P8-29.
35	Module temperature reached	If the heat sink temperature of the inverter module (P7-07) reaches the set module temperature threshold (P8-47), the terminal becomes ON.
36	Software current limit exceeded	Refer to the descriptions of P8-36 and P8-37.
37	Frequency lower limit reached (having output at stop)	If the running frequency reaches the lower limit, the terminal becomes ON. In the stop state, the signal is still ON.
38	Alarm output	If a fault occurs on the AC drive and the AC drive continues to run, the terminal outputs the alarm signal.
39	Motor overheat warning	If the motor temperature reaches the temperature set in P9-58 (Motor overheat warning threshold), the terminal becomes ON. You can view the motor temperature by using U0-34.
40	Current running time reached	If the current running time of AC drive exceeds the value of P8-53, the terminal becomes ON.
41	Fault output	There is no output if it is the coast to stop fault and under voltage occurs.

P5-06	HDO output function selection (Pulse output terminals)	Default	0
-------	---	---------	---



P5-07	AO1 output function selection	Default	0
P5-08	AO2 output function selection	Default	1

The output pulse frequency of the HDO terminal ranges from 0.01 kHz to "Maximum HDO output frequency" (P5-09). The value of P5-09 is between 0.01 kHz and 100.00 kHz.

The output range of AO1 and AO2 is 0–10 V or 0–20 mA. The relationship between pulse and analog output ranges and corresponding functions is listed in the following table.

Table 6-6 Relationship between pulse and analog output ranges and corresponding functions

Value	Function	Range (Corresponding to Pulse or Analog Output Range 0.0%–100.0%)
0	Running frequency	0~maximum output frequency
1	Set frequency	0~maximum output frequency
2	Output current	0~2 times of rated motor current
3	Output torque (absolute value)	0~2 times of rated motor torque
4	Output power	0~2 times of rated power
5	Output voltage	0~1.2 times of rated AC drive voltage
6	HDI Pulse input	0.01kHz~100.00kHz
7	AI1	0V~10V
8	AI2	0V~10V ( OR 0~20mA )
9	AI3	0V~10V
10	Length	0~maximum set length
11	Count value	0 to maximum count value
12	Communication setting	0.0%~100.0%
13	Motor rotational speed	0~rotational speed corresponding to maximum output frequency

14	Output current	0.0A~1000.0A
15	Output voltage	0.0V~1000.0V
16	Output torque (actual value)	-2 times of rated motor torque to 2 times of rated motor torque

P5-09	Maximum HDO output frequency	Default	50.00kHz
	Setting Range	0.01kHz~100.00kHz	

If the terminal is used for pulse output, this parameter is used to set the maximum frequency of pulse output.

P5-10	AO1 offset coefficient	Default	0.0%
	Setting Range	-100.0%~+100.0%	
P5-11	AO1gain	Default	1.00
	Setting Range	-10.00~+10.00	
P5-12	Extension card AO2 offset coefficient	Default	0.00%
	Setting Range	-100.0%~+100.0%	
P5-13	Extension card AO2 gain	Default	1.00
	Setting Range	-10.00~+10.00	

These parameters are used to correct the zero drift of analog output and the output amplitude deviation. They can also be used to define the desired AO curve.

If "b" represents zero offset, "k" represents gain, "Y" represents actual output, and "X" represents standard output, the actual output is:  $Y = kX + b$ .

The zero offset coefficient 100% of AO1 and AO2 corresponds to 10 V (or 20 mA). The standard output refers to the value corresponding to the analog output of 0 to 10 V (or 0 to 20 mA) with no zero offset or gain adjustment.

For example, if the analog output is used as the running frequency, and it is

expected that the output is 8 V when the frequency is 0 and 3 V at the maximum frequency, the gain shall be set to -0.50, and the zero offset shall be set to 80%.

P5-17	FM output delay time	Default	0.0s
	Setting Range	0.0s~3600.0s	
P5-18	TA-TB-TC output delay time	Default	0.0s
	Setting Range	0.0s~3600.0s	
P5-19	TA2-TB2-TC2 output delay time	Default	0.0s
	Setting Range	0.0s~3600.0s	

These parameters are used to set the delay time of output terminals FM, relay 1, relay 2, SP1 and relay 2 from status change to actual output.

P5-22	DO valid mode selection		Default	00000
	Setting Range	Unit's digit	SP1 valid mode	
		0	Positive logic	
		1	Negative logic	
		Ten's digit	Relay 1 valid mode(0~1 , same as SP1)	
		Hundred's digit	Relay 2 valid mode(0~1 , same as SP1)	
		Thousand's digit	SP2 valid mode (0~1 , same as SP1)	
		Ten thousand's digit	Relay 3 valid mode(0~1 , same as SP1)	

It is used to set the logic of output terminals SP1, relay 1, relay 2, SP1 and relay2.

0: Positive logic

The output terminal is valid when being connected with COM, and invalid when being disconnected from COM.

## 1: Positive logic

The output terminal is invalid when being connected with COM, and valid when being disconnected from COM.

### Group P6 Start/Stop Control

P6-00	Start mode		Default	0
	Setting Range	0	Start mode	
	1	Rotational speed tracking restart		
	2	Pre-excited start (asynchronous motor)		

#### 0: Direct start

If the DC braking time is set to 0, the AC drive starts to run at the startup frequency.

If the DC braking time is not 0, the AC drive performs DC braking first and then starts to run at the startup frequency. It is applicable to small-inertia load application where the motor is likely to rotate at startup.

#### 1: Rotational speed tracking restart

The AC drive judges the rotational speed and direction of the motor first and then starts at the tracked frequency. Such smooth start has no impact on the rotating motor. It is applicable to the restart upon instantaneous power failure of large-inertia load. To ensure the performance of rotational speed tracking restart, set the motor parameters in group H1 correctly.

#### 2: Pre-excited start (asynchronous motor)

It is valid only for asynchronous motor and used for building the magnetic field before the motor runs. For pre-excited current and pre-excited time, see parameters of P6-05 and P6-06.

If the pre-excited time is 0, the AC drive cancels pre-excitation and starts to run at startup frequency.

If the pre-excited time is not 0, the AC drive pre-excites first before startup, improving the dynamic response of the motor.

P6-01	Rotational speed tracking mode		Default	0
	Setting Range	0	From frequency at stop	
		1	From zero speed	
		2	From maximum frequency	

To complete the rotational speed tracking process within the shortest time, select the proper mode in which the AC drive tracks the motor rotational speed.

0: From frequency at stop. It is the commonly selected mode.

1: From zero frequency. It is applicable to restart after a long time of power failure.

2: From the maximum frequency. It is applicable to the power-generating load.

P6-02	Rotational speed tracking speed	Default	20
	Setting Range		1~100

In the rotational speed tracking restart mode, select the rotational speed tracking speed. The larger the value is, the faster the tracking is. However, too large value may cause unreliable tracking.

P6-03	Startup frequency	Default	0.00Hz
	Setting Range		0.00Hz~10.00Hz
P6-04	Startup frequency holding time	Default	0.0s
	Setting Range		0.0s~100.0s

To ensure the motor torque at AC drive startup, set a proper startup frequency. In addition, to build excitation when the motor starts up, the startup frequency must be held for a certain period.

The startup frequency (P6-03) is not restricted by the frequency lower limit. If the set target frequency is lower than the startup frequency, the AC drive will not start and stays in the standby state.

During switchover between forward rotation and reverse rotation, the startup frequency holding time is disabled. The holding time is not included in the acceleration time but in the running time of simple PLC.

Example 1:

P0-03 = 0            The frequency source is digital setting.

P0-08 = 2.00Hz    The digital setting frequency is 2.00 Hz.

P6-03 = 5.00Hz    The startup frequency is 5.00 Hz.

P6-04 = 2.0s            The startup frequency holding time is 2.0s. The AC drive stays in the standby state and the output frequency is 0.00 Hz.

Example 2:

P0-03 = 0            The frequency source is digital setting.

P0-08 = 10.00Hz    The digital setting frequency is 10.00 Hz.

P6-03 = 5.00Hz    The startup frequency is 5.00 Hz.

P6-04 = 2.0s            The startup frequency holding time is 2.0s.

In this example, the AC drive accelerates to 5.00 Hz, and then accelerates to the set frequency 10.00 Hz after 2s.

P6-05	Startup DC braking current/Pre-excited current	Default	0%
	Setting Range	0%~100%	
P6-06	Startup DC braking time/Pre-excited time	Default	0.0s
	Setting Range	0.0s~100.0s	

Startup DC braking is generally used during restart of the AC drive after the rotating motor stops. Pre-excitation is used to make the AC drive build magnetic field for the asynchronous motor before startup to improve the responsiveness.

Startup DC braking is valid only for direct start (P6-00 = 0). In this case, the AC drive performs DC braking at the set startup DC braking current. After the startup DC braking time, the AC drive starts to run. If the startup DC braking time is 0, the AC drive starts directly without DC braking. The larger the startup DC braking current is, the larger the braking force is.

If the startup mode is pre-excited start (P6-00 = 3), the AC drive builds magnetic field based on the set pre-excited current. After the pre-excited time, the AC drive starts to run. If the pre-excited time is 0, the AC drive starts directly without pre-excitation.

The startup DC braking current or pre-excited current is a percentage relative to the base value.

P6-07	Acceleration/ Deceleration mode		Default	0
	Setting Range	0	1	2

It is used to set the frequency change mode during the AC drive start and stop process.

#### 0:Linear acceleration/deceleration

The output frequency increases or decreases in linear mode. The CM540 provides four group of acceleration/deceleration time, which can be selected by using P4-00 to P4-08.

#### 1:S-curve acceleration/deceleration A

The output frequency increases or decreases along the S curve. This mode is generally used in the applications where start and stop processes are relatively smooth, such as elevator and conveyor belt. P6-08 and P6-09 respectively define the time proportions of the start segment and the end segment.

#### 2:S-curve acceleration/deceleration B

In this curve, the rated motor frequency  $f$  is always the inflexion point. This mode is usually used in applications where acceleration/deceleration is required at the speed higher than the rated frequency.

When the set frequency is higher than the rated frequency, the acceleration/deceleration time is:

$$t = \left\{ \frac{4}{9} \times \left( \frac{f}{f_b} \right)^2 + \frac{5}{9} \right\} \times T$$

In the formula,  $f$  is the set frequency,  $f_b$  is the rated motor frequency and  $T$  is the acceleration time from 0 Hz to  $f_b$ .

P6-08	Time proportion of S-curve start segment	Default	30.0%
	Setting Range	0.0%~ ( 100.0%-P6-09 )	
P6-09	Time proportion of S-curve end segment	Default	30.0%
	Setting Range	0.0%~ ( 100.0%-P6-08 )	

These two parameters respectively define the time proportions of the start segment and the end segment of S-curve acceleration/deceleration. They must satisfy the requirement:  $P6-08 + P6-09 \leq 100.0\%$ .

In Figure 6-11,  $t_1$  is the time defined in P6-08, within which the slope of the output frequency change increases gradually.  $t_2$  is the time defined in P6-09, within which the slope of the output frequency change gradually decreases to 0. Within the time between  $t_1$  and  $t_2$ , the slope of the output frequency change remains unchanged, that is, linear acceleration/ deceleration.



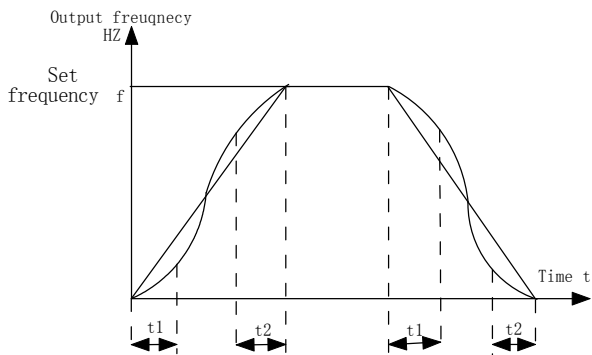
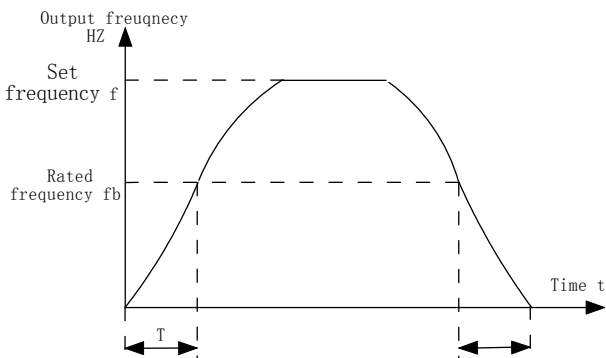

Figure 6-11 S-curve acceleration/deceleration A



6-12 S-curve acceleration/deceleration B

P6-10	Stop mode	Default	0
	Setting Range	0	Decelerate to stop
1		Coast to stop	

0: Decelerate to stop

After the stop command is enabled, the AC drive decreases the output frequency according to the deceleration time and stops when the frequency decreases to zero.

1: Coast to stop

After the stop command is enabled, the AC drive immediately stops the output. The motor will coast to stop based on the mechanical inertia.

P6-11	Initial frequency of stop DC braking	Default	0.00Hz
	Setting Range	0.00Hz~maximum frequency	
P6-12	Waiting time of stop DC braking	Default	0.0s
	Setting Range	0.0s~36.0s	
P6-13	Stop DC braking current	Default	0%
	Setting Range	stop DC braking current	
P6-14	Stop DC braking time	Default	0.0s
	Setting Range	0.0s~36.0s	

Initial frequency of stop DC braking: During the process of decelerating to stop, the AC drive starts DC braking when the running frequency is lower than the value set in P6-11.

Waiting time of stop DC braking: When the running frequency decreases to the initial frequency of stop DC braking, the AC drive stops output for a certain period and then starts DC braking. This prevents faults such as over current caused due to DC braking at high speed.

Stop DC braking current: This parameter specifies the output current at DC braking and is a percentage relative to the base value.

Stop DC braking time: This parameter specifies the holding time of DC braking. If it is set to 0, DC braking is cancelled. The stop DC braking process is shown in the following Figure.

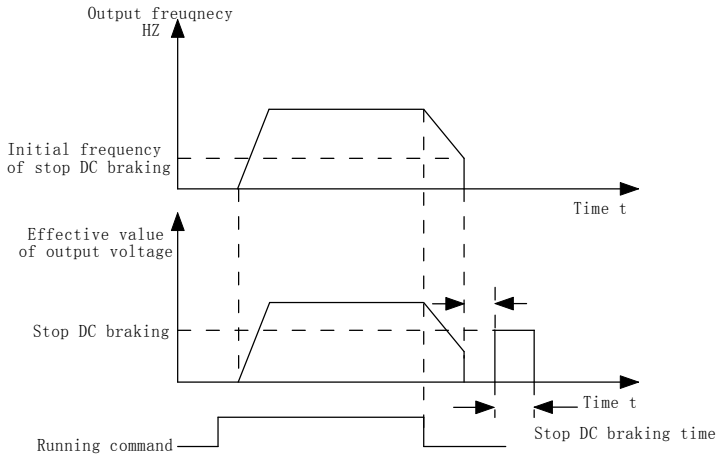

Figure 6-13 Stop DC braking process

P6-15	Brake use ratio	Default	100%
	Setting Range	0%~100%	

It is valid only for the AC drive with internal braking unit and used to adjust the duty ratio of the braking unit. The larger the value of this parameter is, the better the braking result will be. However, too larger value causes great fluctuation of the AC drive bus voltage during the braking process.

### Group P7 Operation Panel and Display

P7-01	MF.K Key function selection	Default	0	
	Setting Range	0	MF.K key disabled	
		1	Switchover between operation panel control and remote command control (terminal or mmunication)	
		2	Switchover between forward rotation and reverse rotation	
		3	Forward JOG	
		4	Reverse JOG	

MF.K key refers to multifunctional key. You can set the function of the MF.K key by using this parameter. You can perform switchover by using this key both in stop or running state.

0: MF.K key disabled

This key is disabled.

1: Switchover between operation panel control and remote command control (terminal or communication)

You can perform switchover from the current command source to the operation panel control (local operation). If the current command source is operation panel control, this key is invalid.

2: Switchover between forward rotation and reverse rotation

You can change the direction of the frequency reference by using the MF.K key. It is valid only when the current command source is operation panel control.

3: Forward JOG

You can perform forward JOG (FJOG) by using the MF.K key.

4: Reverse JOG

You can perform reverse JOG (FJOG) by using the MF.K key.

	STOP/RESET key function	Default	1
P7-02	Setting range	0	STOP/RESET key enabled only in operation panel control
		1	STOP/RESET key enabled in any operation mode

P7-03	LED running display parameter 1	Default	1F
-------	---------------------------------	---------	----

	Setting range	0000 ~ FFFF	<p style="text-align: center;">                 If it needs to display above parameters during the running, Please set the parameter position as 1 and set P7-03 after converting binary number to hexadecimal number.             </p>
P7-04		LED running display parameter 2 Default	0

	Setting range	0000 ~ FFFF	<table border="1"> <tr> <td>7</td><td>6</td><td>5</td><td>4</td><td>3</td><td>2</td><td>1</td><td>0</td> </tr> </table> <ul style="list-style-type: none"> <li>— PID feedback</li> <li>— PID stage</li> <li>— HDI input pulse frequency (KHz)</li> <li>— Running frequency 2 (Hz)</li> <li>— Remained running time</li> <li>— V1 voltage before correction (V)</li> <li>— V2 voltage before correction (V)</li> <li>— V3 voltage before correction (V)</li> </ul>	7	6	5	4	3	2	1	0
			7	6	5	4	3	2	1	0	
<table border="1"> <tr> <td>15</td><td>14</td><td>13</td><td>12</td><td>11</td><td>10</td><td>9</td><td>8</td> </tr> </table> <ul style="list-style-type: none"> <li>— Liner speed</li> <li>— Current power-on time (Hour)</li> <li>— Current running time (Min)</li> <li>— HDI input pulse frequency (KHz)</li> <li>— Communication setting value</li> <li>— Encoder feedback speed (HZ)</li> <li>— Main frequency A display (HZ)</li> <li>— Auxiliary frequency B display (HZ)</li> </ul> <p>If it needs to display above parameters during the running, Please set the parameter position as 1 and set P7-04 after converting binary number to hexadecimal number.</p>	15	14	13	12	11	10	9	8			
15	14	13	12	11	10	9	8				

These parameters are used for checking the parameters when the drives are running

32 units parameters can be checked at most. According to the binary digit of P7-03、P7-04 parameters to select the parameter status display. The order is from P7-03 lowest bit.

	LED drive stop	parameter display	default	0
<p>P7-05</p>	<p>Setting range</p>	<p>0000 ~ FFFF</p>	<p>7 6 5 4 3 2 1 0</p> <ul style="list-style-type: none"> <li>Setting frequency (Hz)</li> <li>Bus voltage (V)</li> <li>S input status</li> <li>D0 output status</li> <li>V1 voltage (V)</li> <li>V2 voltage (V)</li> <li>V3 voltage (V)</li> <li>Count value</li> </ul> <p>15 14 13 12 11 10 9 8</p> <ul style="list-style-type: none"> <li>Length value</li> <li>PLC stage</li> <li>Load speed</li> <li>PID setting</li> <li>HDI input pulse frequency (KHz)</li> <li>Reserved</li> <li>Reserved</li> <li>Reserved</li> </ul>	<p>If it needs to display above parameters during the running, please set the parameter position as 1 and set P7-05 after converting binary number to hexadecimal number.</p>

P7-06	Load speed display coefficient	Default	1.0000
	Setting Range		0.0001~6.5000

This parameter is used to adjust the relationship between the output frequency of the AC drive and the load speed. For details, see the description of P7-12.

P7-07	Heat sink temperature of inverter module	Default	0
	Setting Range		0.0°C~100.0°C

It is used to display the insulated gate bipolar transistor (IGBT) temperature of the inverter module, and the IGBT overheat protection value of the inverter module depends on the model.

P7-08 reserved

P7-09	Temporary software version	Default	0h
	Setting Range		0h~65535h

It is used to display the accumulative running time of the AC drive. After the accumulative running time reaches the value set in P8-17, the terminal with the digital output function 12 becomes ON.

P7-10	Product number		Default	
	Setting Range		AC drive product number	
P7-11	Software version		Default	
	Setting Range		Software version of control board	
P7-12	Number of decimal places for load speed display		Default	0
	Setting Range	0	0 decimal place	
		1	1 decimal place	
		2	2 decimal places	
		3	3 decimal places	



P7-12 is used to set the number of decimal places for load speed display. The following gives an example to explain how to calculate the load speed:

Assume that P7-06 (Load speed display coefficient) is 2.000 and F7-12 is 2 (2 decimal places). When the running frequency of the AC drive is 40.00 Hz, the load speed is  $40.00 \times 2.000 = 80.00$  (display of 2 decimal places).

If the AC drive is in the stop state, the load speed is the speed corresponding to the set frequency, namely, "set load speed". If the set frequency is 50.00 Hz, the load speed in the stop state is  $50.00 \times 2.000 = 100.00$  (display of 2 decimal places).

P7-13	Accumulative power-on time	Default	0h
	Setting Range	0h~65535h	

It is used to display the accumulative power-on time of the AC drive since the delivery. If the time reaches the set power-on time (P8-17), the terminal with the digital output function 24 becomes ON.

P7-14	Accumulative power consumption	Default	-
	Setting Range	0~65535°	

It is used to display the accumulative power consumption of the AC drive until now.

### Group P8 Auxiliary Functions

P8-00	JOG running frequency	Default	2.00Hz
	Setting Range	0.00Hz~maximum frequency	
P8-01	JOG acceleration time	Default	20.0s
	Setting Range	0.0s~6500.0s	
P8-02	JOG deceleration time	Default	20.0s
	Setting Range	0.0s~6500.0s	

These parameters are used to define the set frequency and acceleration/deceleration time of the AC drive when jogging. The startup mode is "Direct start" (P6-00 = 0) and the stop mode is "Decelerate to stop" (P6-10 = 0) during jogging.

P8-03	Acceleration time 2	Default	20.0s
	Setting Range	0.0s~6500.0s	

P8-04	Deceleration time 2	Default	20.0s
	Setting Range	0.0s~6500.0s	
P8-05	Acceleration time 3	Default	20.0s
	Setting Range	0.0s~6500.0s	
P8-06	Deceleration time 3	Default	20.0s
	Setting Range	0.0s~6500.0s	
P8-07	Acceleration time 4	Default	20.0s
	Setting Range	0.0s~6500.0s	
P8-08	Deceleration time 4	Default	20.0s
	Setting Range	0.0s~6500.0s	

P8-09	Jump frequency 1	Default	0.00Hz
	Setting Range	0.00Hz~maximum frequency	
P8-10	Jump frequency 2	Default	0.00Hz
	Setting Range	0.00 Hz~ maximum frequency	

P8-11	Frequency jump amplitude	Default	0.00Hz
	Setting Range	0.00~maximum frequency	

The CM540 provides a total of four groups of acceleration/deceleration time, that is, the preceding three groups and the group defined by P5-17 and P5-18.

Definitions of four groups are completely the same. You can switch over between the four groups of acceleration /deceleration time through different state combinations of S terminals. For more details, see the descriptions of P4-01 to P4-05.

If the set frequency is within the frequency jump range, the actual running frequency is the jump frequency close to the set frequency. Setting the jump frequency helps to avoid the mechanical resonance point of the load.

The CM540 supports two jump frequencies. If both are set to 0, the frequency jump function is disabled. The principle of the jump frequencies and jump amplitude is shown in the following Figure.

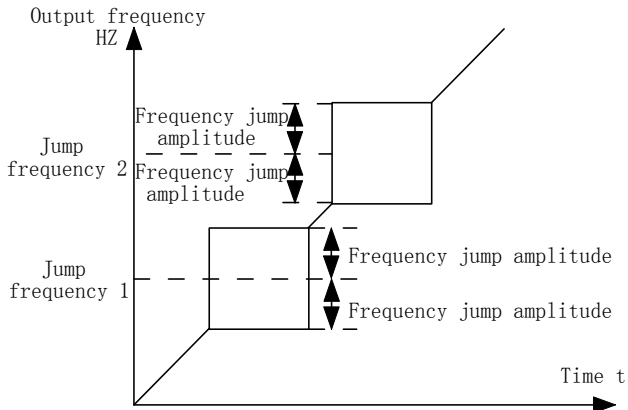

Figure 6-14 Principle of the jump frequencies and jump amplitude

P8-13	Reverse control	Default	0
-------	-----------------	---------	---

P8-12	Forward/Reverse rotation dead-zone time	Default	0.0s
	Setting Range	0.00s~3000.0s	

Setting Range	0	Enabled
	1	Disabled

It is used to set the time when the output is 0 Hz at transition of the AC drive forward rotation and reverse rotation, as shown in the following Figure.

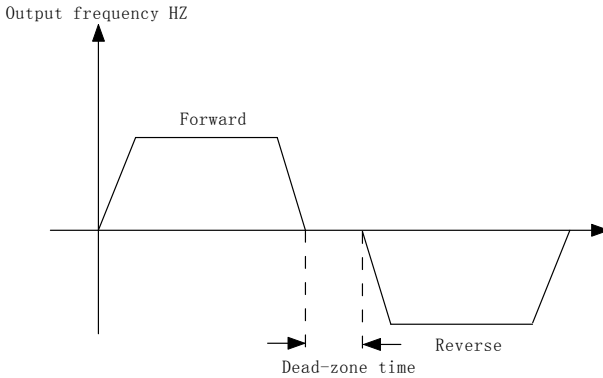

Figure 6-15 Forward/Reverse rotation dead-zone time

It is used to set whether the AC drive allows reverse rotation. In the applications where reverse rotation is prohibited, set this parameter to 1.

P8-14	Running mode when set frequency lower than frequency lower limit		Default	0
	Setting Range	0	Run at frequency lower limit	
		1	Stop	
		2	Run at zero speed	

It is used to set the AC drive running mode when the set frequency is lower than the frequency lower limit. The CM540 provides three running modes to satisfy requirements of various applications.

P8-15	Droop control	Default	0.00Hz
	Setting Range	0.00Hz~10.00Hz	

This function is used for balancing the workload allocation when multiple motors

are used to drive the same load. The output frequency of the AC drives decreases as the load increases. You can reduce the workload of the motor under load by decreasing the output frequency for this motor, implementing workload balancing between multiple motors.

P8-16	Accumulative power-on time threshold	Default	0h
	Setting Range	0h~65000h	

If the accumulative power-on time (P7-13) reaches the value set in this parameter, the corresponding DO terminal becomes ON.

For example, combining virtual DI/DO functions, to implement the function that the AC drive reports an alarm when the actual accumulative power-on time reaches the threshold of 100 hours, perform the setting as follows:

- 1) Set virtual XS1 to user-defined fault 1: H1-00 = 44.
- 2) Set that the valid state of virtual XS 1 is from virtual SP1: H1-05 = 0000.
- 3) Set virtual XDO1 to power-on time reached: H1-11= 24.
- 4) Set the accumulative power-on time threshold to 100 h: P8-16 = 100 h.

Then, the AC drive reports E024 when the accumulative power-on time reaches 100 hours.

P8-17	Accumulative running time threshold	Default	0h
	Setting Range	0h~65000h	

It is used to set the accumulative running time threshold of the AC drive.

If the accumulative running time (P7-09) reaches the value set in this parameter, the corresponding DO terminal becomes ON.

P8-18	Startup protection		Default	0
	Setting Range	0	No	
		1	Yes	

This parameter is used to set whether to enable the safety protection. If it is set to 1, the AC drive does not respond to the run command valid upon AC drive power-on (for example, an input terminal is ON before power-on). The AC drive responds only after the run command is cancelled and becomes valid again.

In addition, the AC drive does not respond to the run command valid upon fault reset of the AC drive. The run protection can be disabled only after the run command is cancelled. In this way, the motor can be protected from responding to run commands upon power-on or fault reset in unexpected conditions.

P8-19	Frequency detection value ( FDT1 )	Default	50.00Hz
	Setting Range	0.00Hz~maximum frequency	
P8-20	Frequency detection hysteresis(FDT1)	Default	5.0%
	Setting Range	0.0%~100.0% ( FDT1 level )	

If the running frequency is higher than the value of P8-19, the corresponding DO terminal becomes ON. If the running frequency is lower than value of P8-19, the DO terminal goes OFF.

These two parameters are respectively used to set the detection value of output frequency and hysteresis value upon cancellation of the output. The value of P8-20 is a percentage of the hysteresis frequency to the frequency detection value (P8-19).

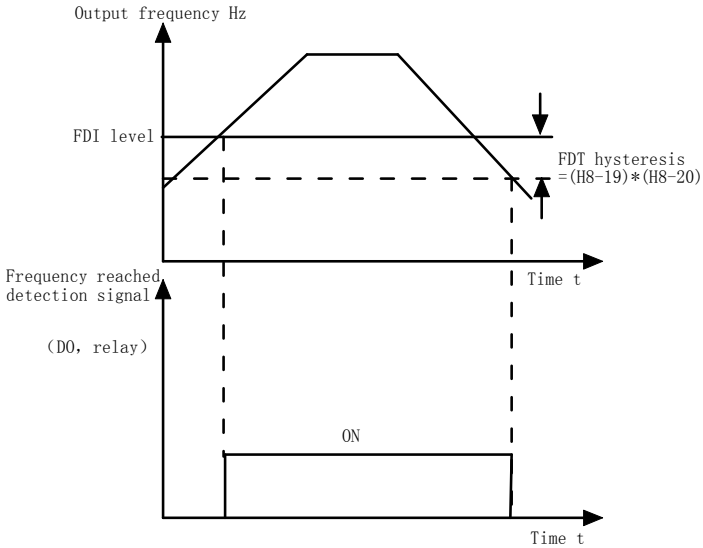

Figure 6-16 FDT FDT level

P8-21	Detection range of frequency reached	Default	0.0%
	Setting Range	0.00~100% (maximum frequency)	

If the AC drive running frequency is within the certain range of the set frequency, the corresponding DO terminal becomes ON.

This parameter is used to set the range within which the output frequency is detected to reach the set frequency. The value of this parameter is a percentage relative to the maximum frequency. The detection range of frequency reached is shown in the following Figure.

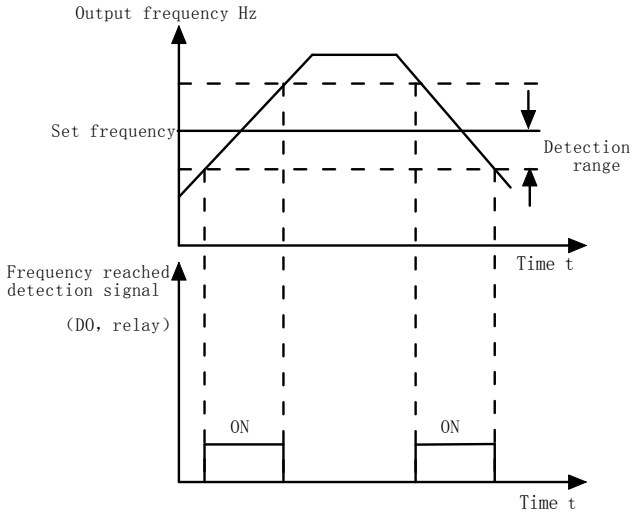

Figure 6-17 Detection range of frequency reached

P8-22	Jump frequency during acceleration/deceleration	Default	0
	Setting Range	0:Disabled 1:Enabled	

It is used to set whether the jump frequencies are valid during acceleration/deceleration.

When the jump frequencies are valid during acceleration/deceleration, and the running frequency is within the frequency jump range, the actual running frequency will jump over the set frequency jump amplitude (rise directly from the lowest jump frequency to the highest jump frequency). The following Figure shows the diagram when the jump frequencies are valid during acceleration/deceleration.



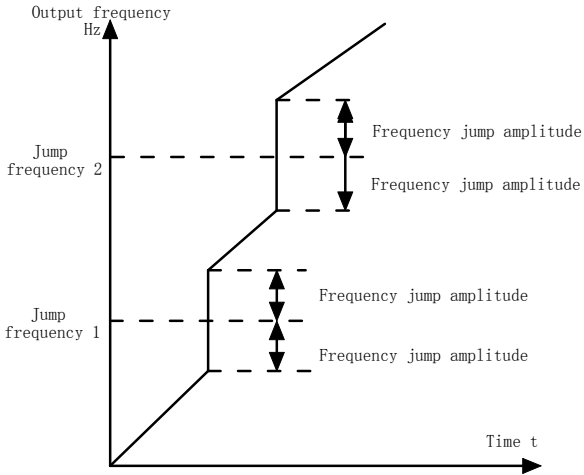

Figure 6-18 Diagram when the jump frequencies are valid during acceleration/deceleration

P8-25	Frequency switchover point between acceleration time 1 and acceleration time 2	Default	0.00Hz
	Setting Range	0.00Hz~maximum frequency	
P8-26	Frequency switchover point between deceleration time 1 and deceleration time 2	Default	0.00Hz
	Setting Range	0.00Hz~maximum frequency	

This function is valid when motor 1 is selected and acceleration/deceleration time switchover is not performed by means of DI terminal. It is used to select different groups of acceleration/ deceleration time based on the running frequency range rather than S terminal during the running process of the AC drive.

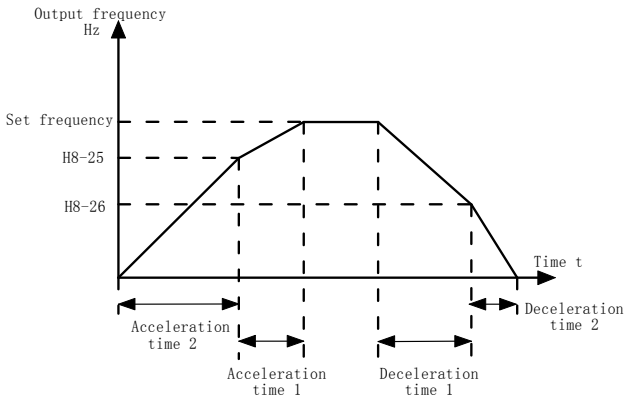

Figure 6-19 Acceleration/deceleration time switchover

During acceleration, if the running frequency is smaller than the value of P8-25, acceleration time 2 is selected. If the running frequency is larger than the value of P8-25, acceleration time 1 is selected.

During deceleration, if the running frequency is larger than the value of P8-26, deceleration time 1 is selected. If the running frequency is smaller than the value of P8-26, deceleration time 2 is selected.

P8-27	Terminal JOG preferred	Default	0
	Setting Range	0:Disabled	1:Enabled

It is used to set whether terminal JOG is preferred.

If terminal JOG is preferred, the AC drive switches to terminal JOG running state when there is a terminal JOG command during the running process of the AC drive.

P8-28	Frequency detection value ( FDT2	Default	50.00Hz
	Setting Range	0.00Hz~maximum frequency	
P8-29	Frequency detection hysteresis ( FDT2 )	Default	5.0%
	Setting Range	0.0%~100.0% ( FDT2 level )	

The frequency detection function is the same as FDT1 function. For details, refer to the descriptions of P8-19 and P8-20.

P8-30	Any frequency reaching detection value 1	Default	50.00Hz
	Setting Range	0.00Hz~maximum frequency	
P8-31	Any frequency reaching detection amplitude 1	Default	0.0%
	Setting Range	0.0%~100.0%(maximum frequency)	
P8-32	Any frequency reaching detection value 2	Default	50.00Hz
	Setting Range	0.00Hz~maximum frequency	
P8-33	Any frequency reaching detection amplitude 2	Default	0.0%
	Setting Range	0.0%~100.0% (maximum frequency)	

If the output frequency of the AC drive is within the positive and negative amplitudes of the any frequency reaching detection value, the corresponding DO becomes ON.

The CM540 provides two groups of any frequency reaching detection parameters, including frequency detection value and detection amplitude, as shown in the following Figure.

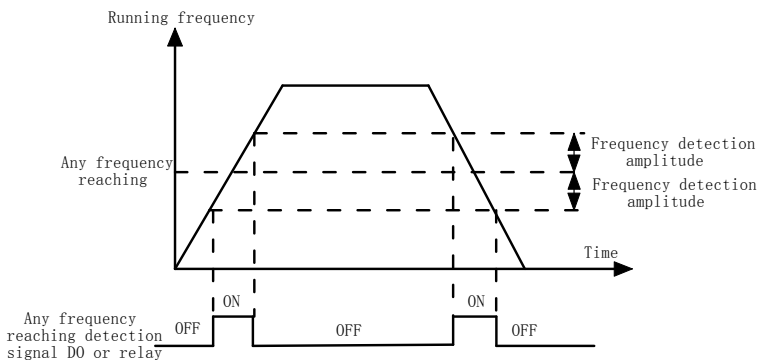

Figure 6-20 Any frequency reaching detection

P8-34	Zero current detection level	Default	5.0%
	Setting Range	0.0%~300.0% (rated motor current)	
P8-35	Zero current detection delay time	Default	0.10s
	Setting Range	0.00s~600.00s	

If the output current of the AC drive is equal to or less than the zero current detection level and the duration exceeds the zero current detection delay time, the corresponding DO becomes ON. The zero current detection is shown in the following Figure.

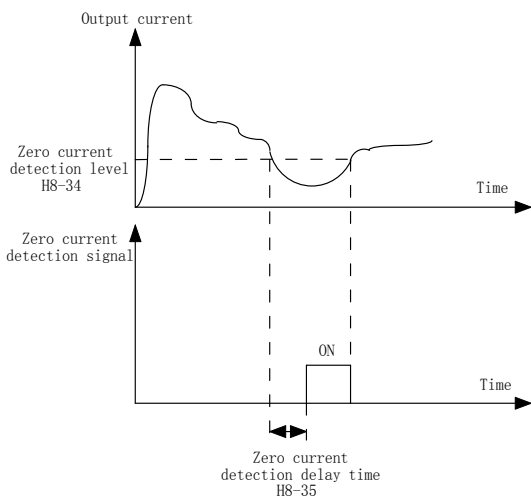

Figure 6-21 Zero current detection

P8-36	Output over current threshold	Default	200.0%
	Setting Range	0.0% ( no detection ) 0.1%~300.0% (rated motor current)	
P8-37	Output over current detection delay time	Default	0.00s
	Setting Range	0.00s~600.00s	

If the output current of the AC drive is equal to or higher than the over current threshold and the duration exceeds the detection delay time, the corresponding

DO becomes ON. The output over current detection function is shown in the following Figure.

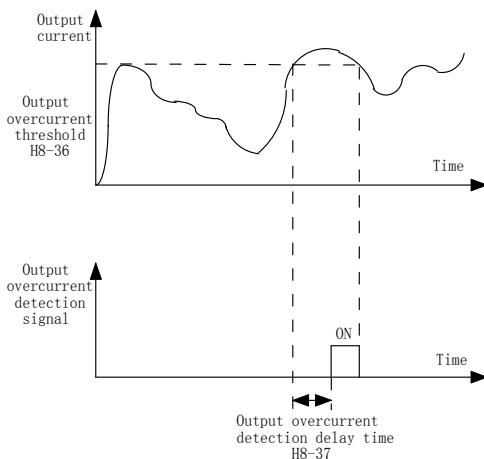

Figure 6-22 Output over current detection

P8-38	Any current reaching 1	Default	100.0%
	Setting Range	0.0%~300.0% ( rated motor current )	
P8-39	Any current reaching 1 amplitude	Default	0.0%
	Setting Range	0.0%~300.0% (rated motor current)	
P8-40	Any current reaching 2	Default	100.0%
	Setting Range	0.0%~300.0% (rated motor current)	
P8-41	Any current reaching 2 amplitude	Default	0.0%
	Setting Range	0.0%~300.0% (rated motor current)	

If the output current of the AC drive is within the positive and negative amplitudes of any current reaching detection value, the corresponding DO becomes ON.

The CM540 provides two groups of any current reaching detection parameters, including current detection value and detection amplitudes, as shown in the following Figure.

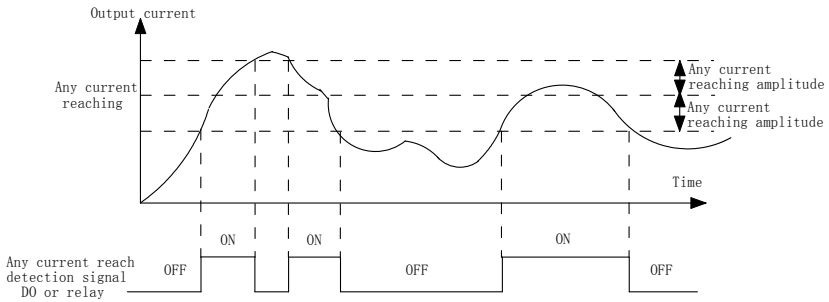

Figure 6-23 Any current reaching detection

P8-42	Timing function		Default	0
	Setting Range	0	Disabled	
		1	Enabled	
P8-43	Timing duration source		Default	0
	Setting Range	0	P8-44	
		1	AI1	
		2	AI2	
		3	AI3	
		100% of analog input corresponds to the value of P8-44		
P8-44	Timing duration		Default	0.0Min
	Setting Range		0.0Min~6500.0Min	

These parameters are used to implement the AC drive timing function.

If P8-42 is set to 1, the AC drive starts to time at startup. When the set timing duration is reached, the AC drive stops automatically and meanwhile the corresponding DO becomes ON.

The AC drive starts timing from 0 each time it starts up and the remaining timing duration can be queried by U0-20.

The timing duration is set in P8-43 and P8-44, in unit of minute.

P8-45	AI1 input voltage lower limit	Default	3.10V
	Setting Range	0.00V~P8-46	
P8-46	AI1 input voltage upper limit	Default	6.80V
	Setting Range	P8-45~10.00V	

These two parameters are used to set the limits of the input voltage to provide protection on the AC drive. When the AI1 input is larger than the value of P8-46 or smaller than the value of P8-45, the corresponding DO becomes ON, indicating that AI1 input exceeds the limit.

P8-47	Module temperature threshold	Default	75°C
	Setting Range	0.00V~P8-46	

When the heat sink temperature of the AC drive reaches the value of this parameter, the corresponding DO becomes ON, indicating that the module temperature reaches the threshold.

P8-48	Wakeup pressure deviation	Default	0
	Setting Range	0: fan rotating during drive running 1: fan keeping rotating	

Wakeup pressure deviation: When the current press is less than the (Pressure setting value\* \*P8-48),it wakes up counting

Default : 50.0% ;

Setting non-0.0%,the pressure wakeup is valid, the frequency wakeup is invalid.

Setting 0.0%, the pressure wakeup is invalid, the frequency wakeup is valid

During the frequency wakeup, the PID must be in operation ( PA-28=1 )even the drives stop.

P8-49	Wakeup frequency	Default	0.00Hz
	Setting Range	Dormant frequency ( P8-51 ) ~maximum	
P8-50	Wakeup delay time	Default	0.0s
	Setting Range	0.0s~6500.0s	
P8-51	Dormant frequency	Default	0.00Hz
	Setting Range	0.00Hz~wakeup frequency ( P8-49 )	
P8-52	Dormant delay time	Default	0.0s
	Setting Range	0.0s~6500.0s	

These parameters are used to implement the dormant and wakeup functions in the water supply application.

When the AC drive is in running state, the AC drive enters the dormant state and stops automatically after the dormant delay time (P8-52) if the set frequency is lower than or equal to the dormant frequency (P8-51).

When the AC drive is in dormant state and the current running command is effective, the AC drives starts up after the wakeup delay time (P8-50) if the set frequency is higher than or equal to the wakeup frequency (P8-49).

Generally, set the wakeup frequency equal to or higher than the dormant frequency. But when the P8-48 is not equal to 0.0%, the pressure deviation wakeup will be in priority. If the wakeup frequency and dormant frequency are set to 0, the dormant and wakeup functions are disabled.

When the dormant function is enabled, if the frequency source is PID, whether PID

operation is performed in the dormant state is determined by PA-28. In this case, select PID operation enabled in the stop state (PA-28 = 1).

P8-53	Current running time reached	Default	0.0Min
	Setting Range	0.0Min~6500.0Min	

If the current running time reaches the value set in this parameter, the



corresponding DO becomes ON, indicating that the current running time is reached.

### Group P9 Fault and Protection

P9-00	Motor overload protection selection	Default	1
	Setting Range	0	Disabled
		1	Enabled
P9-01	Motor overload protection gain	Default	1.00
	Setting Range	0.20~w10.00	

P9-00 = 0

The motor overload protective function is disabled. The motor is exposed to potential damage due to overheating. A thermal relay is suggested to be installed between the AC drive and the motor.

P9-00 = 1

The AC drive judges whether the motor is overloaded according to the inverse time-lag curve of the motor overload protection.

The inverse time-lag curve of the motor overload protection is:

220% x P9-01 x rated motor current (if the load remains at this value for one minute, the AC drive reports motor overload fault), or 150% x P9-01 x rated motor current (if the load remains at this value for 60 minutes, the AC drive reports motor overload fault)

Set P9-01 properly based on the actual overload capacity. If the value of P9-01 is set too large, damage to the motor may result because the motor overheats but the AC drive does not report the alarm.

P9-02	Motor overload warning coefficient	Default	80%
	Setting Range	50%~100%	

This function is used to give a warning signal to the control system via DO before

motor overload protection. This parameter is used to determine the percentage, at which prewarning is performed before motor overload. The larger the value is, the less advanced the pre-warning will be.

When the accumulative output current of the AC drive is greater than the value of the overload inverse time-lag curve multiplied by P9-02, the DO terminal on the AC drive allocated with function 6 (Motor overload pre-warning) becomes ON.

P9-03	Overvoltage stall gain	Default	0
	Setting Range	0 ( no stall overvoltage ) ~100	
P9-04	Overvoltage stall protective voltage	Default	130%
	Setting Range	120%~150% ( three phase )	

When the DC bus voltage exceeds the value of P9-04 (Overvoltage stall protective voltage) during deceleration of the AC drive, the AC drive stops deceleration and keeps the present running frequency. After the bus voltage declines, the AC drive continues to decelerate. P9-03 (Overvoltage stall gain) is used to adjust the overvoltage suppression capacity of the AC drive. The larger the value is, the greater the overvoltage suppression capacity will be.

For small-inertia load, the value should be small. Otherwise, the system dynamic response will be slow. For large-inertia load, the value should be large. Otherwise, the suppression result will be poor and an overvoltage fault may occur.

If the overvoltage stall gain is set to 0, the overvoltage stall function is disabled.

P9-05	Over current stall gain	Default	20
	Setting Range	0~100	
P9-06	Over current stall protective current	Default	180%
	Setting Range	100%~200%	

When the output current exceeds the over current stall protective current during acceleration/deceleration of the AC drive, the AC drive stops acceleration/deceleration and keeps the present running frequency. After the

output current declines, the AC drive continues to accelerate/decelerate.

P9-05 (Over current stall gain) is used to adjust the over current suppression capacity of the AC drive. The larger the value is, the greater the over current suppression capacity will be. In the prerequisite of no over current occurrence, set P9-05 to a small value.

For small-inertia load, the value should be small. Otherwise, the system dynamic response will be slow. For large-inertia load, the value should be large.

Otherwise, the suppression result will be poor and over current fault may occur.

If the over current stall gain is set to 0, the over current stall function is disabled.

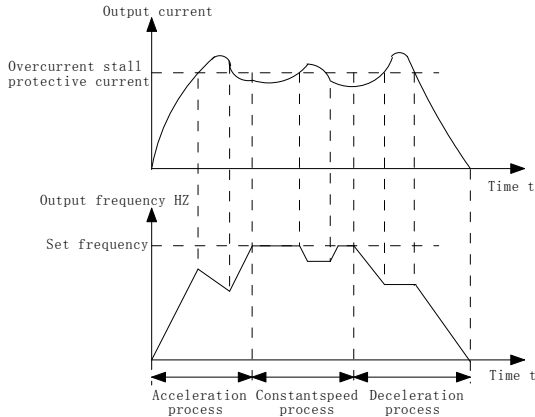

Figure 6-24 Diagram of the over current stall protection function

P9-07	Short-circuit to ground upon power on		Default	1
	Setting Range	0	Disabled	
		1	Enabled	

It is used to determine whether to check the motor is short-circuited to ground at power-on of the AC drive. If this function is enabled, the AC drive's UVW will have voltage output a while after power-on.

P9-09	Fault auto reset times	Default	0
	Setting Range	0~20	

It is used to set the times of fault auto resets if this function is used. After the value is exceeded, the AC drive will remain in the fault state.

P9-10	DO action during fault auto reset	Default	1
	Setting Range	0:Not act	1:Act

It is used to decide whether the DO acts during the fault auto reset if the fault auto reset function is selected

P9-11	Time interval of fault auto reset	Default	1.0s
	Setting Range	0.1s~100.0s	

It is used to set the waiting time from the alarm of the AC drive to fault auto reset.

P9-12	Input phase loss protection/contactor energizing protection selection	Default	11
	Setting Range	0:Disabled;1:Enabled	

CM540 ac drive G7.Kw and above have the input phase loss protect function.

P9-13	Output phase loss protection selection	Default	1
	Setting Range	0:Disabled	1:Enabled

It is used to determine whether to perform output phase loss protection.

P9-14	1st fault type	0~99
P9-15	2nd fault type	
P9-16	3rd (latest) fault type	

It is used to record the types of the most recent three faults of the AC drive. 0 indicates no fault. For possible causes and solution of each fault, refer to Chapter 8.

P9-17	Frequency upon 3rd fault	It displays the frequency when the latest fault occurs
-------	--------------------------	--

P9-18	Current upon 3rd fault	It displays the current when the latest fault occurs.																				
P9-19	Bus voltage upon 3rd fault	It displays the bus voltage when the latest fault occurs.																				
P9-20	S status upon 3rd fault	<p>It displays the status of all S terminals when the latest fault occurs.</p> <p>The sequence is as follows:</p> <table border="1" style="margin-left: auto; margin-right: auto;"> <tr> <td>BIT9</td><td>BIT8</td><td>BIT7</td><td>BIT6</td><td>BIT5</td><td>BIT4</td><td>BIT3</td><td>BIT2</td><td>BIT1</td><td>BIT0</td> </tr> <tr> <td></td><td></td><td>S8</td><td>S7</td><td>S6</td><td>S5</td><td>S4</td><td>S3</td><td>S2</td><td>S1</td> </tr> </table> <p>If a S is ON, the setting is 1. If the S is OFF, the setting is 0. The value is the equivalent decimal number converted from the S status.</p>	BIT9	BIT8	BIT7	BIT6	BIT5	BIT4	BIT3	BIT2	BIT1	BIT0			S8	S7	S6	S5	S4	S3	S2	S1
BIT9	BIT8	BIT7	BIT6	BIT5	BIT4	BIT3	BIT2	BIT1	BIT0													
		S8	S7	S6	S5	S4	S3	S2	S1													
P9-21	Output terminal status upon 3rd fault	<p>It displays the status of all output terminals when the latest fault occurs. The sequence is as follows:</p> <table border="1" style="margin-left: auto; margin-right: auto;"> <tr> <td>BIT4</td><td>BIT3</td><td>BIT2</td><td>BIT1</td><td>BIT0</td> </tr> <tr> <td>relay 3</td><td>SP2 2</td><td>relay 1</td><td>relay 1</td><td>SP1</td> </tr> </table> <p>If an output terminal is ON, the setting is 1. If the output terminal is OFF, the setting is 0. The value is the equivalent decimal number converted from the DO statuses.</p>	BIT4	BIT3	BIT2	BIT1	BIT0	relay 3	SP2 2	relay 1	relay 1	SP1										
BIT4	BIT3	BIT2	BIT1	BIT0																		
relay 3	SP2 2	relay 1	relay 1	SP1																		
P9-22	AC drive status upon 3rd fault	Reserved																				
P9-23	Power-on time upon 3rd fault	It displays the present power-on time when the latest fault occurs.																				
P9-24	Running time upon 3rd fault	It displays the present running time when the latest fault occurs.																				
P9-27	Frequency upon 2nd fault	Same as P9-17~P9-24																				
P9-28	Current upon 2nd fault	Same as P9-17~P9-24																				
P9-29	Bus voltage upon 2nd fault																					
P9-30	S status upon 2nd fault																					
P9-31	Output terminal status upon 2nd fault																					
P9-32	Frequency upon 2nd fault																					
P9-33	Power on upon 2nd fault																					
P9-34	Running time upon 2nd fault																					

P9-47	Fault protection action selection 1		Default	00000
	Setting Range	Unit's digit	(Motor overload ( E011 )	
		0	Coast to stop	
		1	Stop according to the stop mode	
		2	Continue to run	
		Ten's digit	Power input phase loss ( E012 )	
		Hundred's digit	Power output phase loss ( E013 )	
		Thousand's digit	External equipment fault ( E015 )	
Ten thousand's digit	Communication fault, ( E016 )			
P9-48	Fault protection action selection 2		Default	00000
	Setting Range	Unit's digit	Encoder fault ( E020 )	
		0	Coast to stop	
		1	Switch over to V/F control, stop according to the stop mode	
		2	Switch over to V/F control, continue to run	
		Ten's digit	EEPROM read-write fault ( E021 )	
0	Coast to stop			
P9-48	Setting Range	1	Stop according to the stop mode	
		Hundred's digit	retain	
		Thousand's digit	Motor overheat ( E025 ) ( Same as P9-47 Unit's digit )	
		Ten thousand's digit	Accumulative running time reached(E026) (Same as P9-47 Unit's digit)	
P9-49	Fault protection action selection 3		Default	00000

	Setting Range	Unit's digit	Fault protection action selection 1(E027) (Same as P9-47 Unit's digit)	
		Ten's digit	Fault protection action selection 2(E028) (Same as P9-47 Unit's digit)	
		Hundred's digit	Accumulative power-on time reached(E029) (Same as P9-47 Unit's digit)	
		Thousand's digit	Load becoming ( E030 )	
		0	Coast to stop	
		1	Stop according to the stop mode	
		2	Continue to run at 7% of rated motor frequency and resume to the set frequency if the load recovers	
		Ten thousand's digit	PID feedback lost during running(E031) (Same as unit's digit in P9-47)	
P9-50	Fault protection action selection 4		Default	00000
	Setting Range	Unit's digit	Too large speed deviation,(E042) (Same as unit's digit in P9-47)	
		Ten's digit	Motor over-speed ( E043 )	
		Hundred's digit	Initial position fault ( E051 )	
		Thousand's digit	Speed feedback fault ( E052 )	
		Ten thousand's digit	Retain	

If "Coast to stop" is selected, the AC drive displays E0\*\* and directly stops.

- If "Stop according to the stop mode" is selected, the AC drive displays A\*\* and stops according to the stop mode. After stop, the AC drive displays E0\*\*.
- If "Continue to run" is selected, the AC drive continues to run and displays A\*\*. The running frequency is set in P9-54.

P9-54	Frequency selection for continuing to run upon fault		Default	0
	Setting Range	0	Current running frequency	
		1	Set frequency	
		2	Frequency upper limit	
		3	Frequency lower limit	
	4	Backup frequency upon abnormality		
P9-55	Backup frequency upon abnormality		Default	100.0%
	Setting Range		0.0%~100.0%	

If a fault occurs during the running of the AC drive and the handling of fault is set to "Continue to run", the AC drive displays A\*\* and continues to run at the frequency set in P9-54.

The setting of P9-55 is a percentage relative to the maximum frequency.

P9-56	Type of motor temperature sensor		Default	0
	Setting Range	0	No temperature sensor	
		1	PT100	
P9-57	Motor overheat protection threshold		Default	110°C
	Setting Range		0°C~200°C	
P9-58	Motor overheat warning threshold		Default	90°C
	Setting Range		0°C~200°C	

The signal of the motor temperature sensor needs to be connected to the optional I/O extension card. AI3 on the extension card can be used for the temperature signal input. The motor temperature sensor is connected to AI3 and PGND of the extension card.

The AI3 terminal of the CM540 supports both PT100. Set the sensor type correctly during the use. You can view the motor temperature via U0-34.



If the motor temperature exceeds the value set in P9-57, the AC drive reports an alarm and acts according to the selected fault protection action.

If the motor temperature exceeds the value set in P9-58, the DO terminal on the AC drive allocated with function 39 (Motor overheat warning) becomes ON.

P9-59	Action selection at instantaneous power failure		Default	0
	Setting Range	0	Invalid	
		1	Decelerate	
		2	Decelerate to stop	
P9-60	Action pause judging voltage at instantaneous power failure		Default	90.0%
	Setting Range		80.0%~100.0%	
P9-61	Voltage rally judging time at instantaneous power failure		Default	0.50s
	Setting Range		0.00s~100.00s	
P9-62	Action judging voltage at instantaneous power failure		Default	80.0%
	Setting Range		60.0%~100.0% ( standard bus voltage )	

Upon instantaneous power failure or sudden voltage dip, the DC bus voltage of the AC drive reduces. This function enables the AC drive to compensate the DC bus voltage reduction with the load feedback energy by reducing the output frequency so as to keep the AC drive running continuously.

If P9-59 = 1, upon instantaneous power failure or sudden voltage dip, the AC drive decelerates. Once the bus voltage resumes to normal, the AC drive accelerates to the set frequency. If the bus voltage remains normal for the time exceeding the value set in P9-61, it is considered that the bus voltage resumes to normal.

If P9-59 = 2, upon instantaneous power failure or sudden voltage dip, the AC drive decelerates to stop.

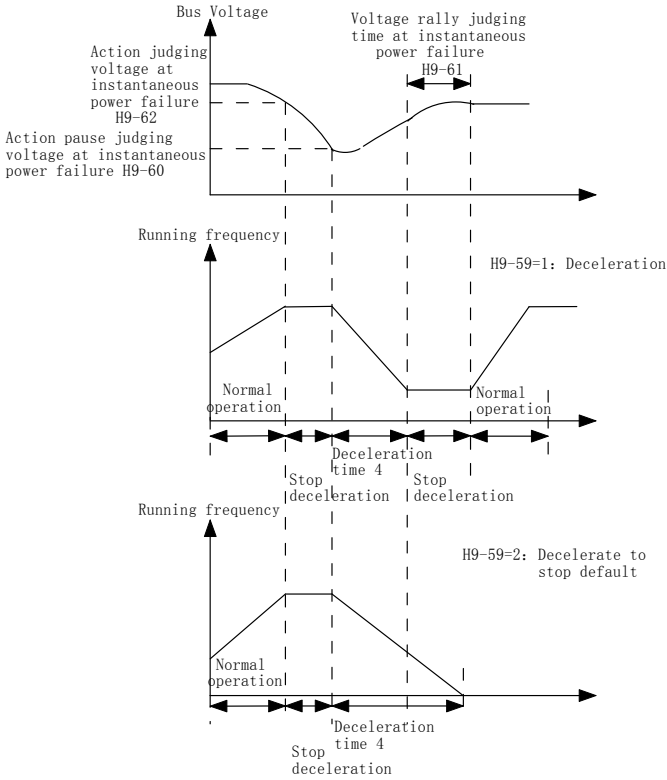

Figure 6-25 AC drive action diagram upon instantaneous power failure

P9-63	Protection upon load becoming 0		Default	0
	Setting Range	0	Disabled	
1		Enabled		
P9-64	Detection level of load becoming 0		Default	10.0%
	Setting Range		0.0%~100.0% ( rated motor current )	
P9-65	Detection time of load becoming 0		Default	1.0s
	Setting Range		0.0s~60.0s	

If protection upon load becoming 0 is enabled, when the output current of the AC drive is lower than the detection level (P9-64) and the lasting time exceeds the

detection time (P9-65), the output frequency of the AC drive automatically declines to 7% of the rated frequency. During the protection, the AC drive automatically accelerates to the set frequency if the load resumes to normal.

P9-67	Over-speed detection value	Default	20.0%
	Setting Range	0.0%~50.0% (maximum frequency)	
P9-68	Over-speed detection time	Default	1.0s
	Setting Range	0.0s NO TEST 0.1s~60.0s	

This function is valid only when the AC drive runs in the CLVC mode.

If the actual motor rotational speed detected by the AC drive exceeds the maximum frequency and the excessive value is greater than the value of P9-67 and the lasting time exceeds the value of P9-68, the AC drive reports E043 and acts according to the selected fault protection action. If the over-speed detection time is 0.0s, the over-speed detection function is disabled.

P9-69	Detection value of too large speed deviation	Default	20.0%
	Setting Range	0.0%~50.0% (maximum frequency)	
P9-70	Detection time of too large speed deviation	Default	5.0s
	Setting Range	0.0s NO TEST 0.1s~60.0s	

This function is valid only when the AC drive runs in the CLVC mode.

If the AC drive detects the deviation between the actual motor rotational speed detected by the AC drive and the set frequency is greater than the value of P9-69 and the lasting time exceeds the value of P9-70, the AC drive reports E042 and according to the selected fault protection action.

If P9-70 (Detection time of too large speed deviation) is 0.0s, this function is disabled.

### Group PA Process Control PID Function

PID control is a general process control method. By performing proportional, integral and differential operations on the difference between the feedback signal

and the target signal, it adjusts the output frequency and constitutes a feedback system to stabilize the controlled counter around the target value.

It is applied to process control such as flow control, pressure control and temperature control. The following Figure shows the principle block diagram of PID control.

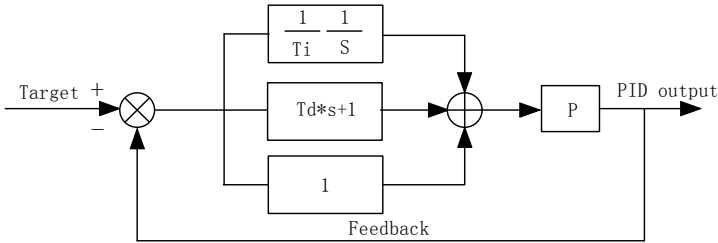

Figure 6-26 Principle block diagram of PID control

	PID setting source		Default	0
	PA-00	Setting Range	0	PA-01 setting
1			AI1	
2			AI2	
3			AI3	
4			HDI Pulse setting ( S5 )	
5			Communication setting	
6			Multi-reference	
PA-01	PID digital setting		Default	50.0%
	Setting Range		0.0%~100.0%	

PA-00 is used to select the channel of target process PID setting. The PID setting is a relative value and ranges from 0.0% to 100.0%. The PID feedback is also a relative value.

The purpose of PID control is to make the PID setting and PID feedback equal.

PA-02	PID feedback source		Default	0
	Setting Range	0	AI1	
		1	AI2	
		2	AI3	
		3	AI1 - AI2	
		4	HDI Pulse setting ( S5 )	
		5	Communication setting	
		6	AI1+AI2	
		7	MAX (  AI1 , AI2  )	
		8	MIN (  AI1 , AI2  )	

This parameter is used to select the feedback signal channel of process PID.

The PID feedback is a relative value and ranges from 0.0% to 100.0%.

PA-03	PID action direction		Default	0
	Setting Range	0	Forward action	
		1	Reverse action	

0: Forward action

When the feedback value is smaller than the PID setting, the AC drive's output frequency rises. For example, the winding tension control requires forward PID action.

1: Reverse action

When the feedback value is smaller than the PID setting, the AC drive's output frequency reduces. For example, the unwinding tension control requires reverse PID action.

Note that this function is influenced by the DI function 35 "Reverse PID action direction".

PA-04	PID setting feedback range	Default	1000
	Setting Range	0~65535	

This parameter is a non-dimensional unit. It is used for PID setting display (U0-15) and PID feedback display (U0-16).

Relative value 100% of PID setting feedback corresponds to the value of PA-04. If PA-04 is set to 2000 and PID setting is 100.0%, the PID setting display (U0-15) is 2000.

PA-05	Proportional gain Kp1	Default	20.0
	Setting Range	0.0~100.0	
PA-06	Integral time Ti1	Default	2.00s
	Setting Range	0.01s~10.00s	
PA-07	Differential time Td1	Default	0.000s
	Setting Range	0.00~10.000	

#### PA-05 (Proportional gain Kp1)

It decides the regulating intensity of the PID regulator. The higher the Kp1 is, the larger the regulating intensity is. The value 100.0 indicates when the deviation between PID feedback and PID setting is 100.0%, the adjustment amplitude of the PID regulator on the output frequency reference is the maximum frequency.

#### PA-06 (Integral time Ti1)

It decides the integral regulating intensity. The shorter the integral time is, the larger the regulating intensity is. When the deviation between PID feedback and PID setting is 100.0%, the integral regulator performs continuous adjustment for the time set in PA- 06. Then the adjustment amplitude reaches the maximum frequency.

#### PA-07 (Differential time Td1)

It decides the regulating intensity of the PID regulator on the deviation change. The longer the differential time is, the larger the regulating intensity is. Differential

time is the time within which the feedback value change reaches 100.0%, and then the adjustment amplitude reaches the maximum frequency.

PA-08	Cut-off frequency of PID reverse rotation	Default	2.00Hz
	Setting Range	0.00~ Maximum frequency	

In some situations, only when the PID output frequency is a negative value (AC drive reverse rotation), PID setting and PID feedback can be equal. However, too high reverse rotation frequency is prohibited in some applications, and PA-08 is used to determine the reverse rotation frequency upper limit.

PA-09	PID deviation limit	Default	0.01%
	Setting Range	0.0%~100.0%	

If the deviation between PID feedback and PID setting is smaller than the value of PA-09, PID control stops. The small deviation between PID feedback and PID setting will make the output frequency stabilize, effective for some closed-loop control applications.

PA-10	PID differential limit	Default	0.10%
	Setting Range	0.0%~100.0%	

It is used to set the PID differential output range. In PID control, the differential operation may easily cause system oscillation. Thus, the PID differential regulation is restricted to a small range.

PA-11	PID setting change time	Default	0.00s
	Setting Range	0.00s~650.00s	

The PID setting change time indicates the time required for PID setting changing from 0.0% to 100.0%. The PID setting changes linearly according to the change time, reducing the impact caused by sudden setting change on the system.

PA-12	PID feedback filter time	Default	0.00s
-------	--------------------------	---------	-------

	Setting Range	0.00s~60.00s	
PA-13	PID output filter time	Default	0.00s
	Setting Range	0.00s~60.00s	

PA-12 is used to filter the PID feedback, helping to reduce interference on the feedback but slowing the response of the process closed-loop system.

PA-13 is used to filter the PID output frequency, helping to weaken sudden change of the AC drive output frequency but slowing the response of the process closed-loop system.

PA-15	Proportional gain Kp2		Default	20.0
	Setting Range		0.0~100.0	
PA-16	Integral time Ti2		Default	2.00s
	Setting Range		0.01s~10.00s	
PA-17	Differential time Td2		Default	0.000s
	Setting Range		0.00~10.000	
PA-18	PID parameter switchover condition		Default	0
	Setting Range	0	No switchover	
		1	Switchover via S	
		2	Automatic switchover based on deviation	
PA-19	PID parameter switchover deviation 1		Default	20.0%
	Setting Range		0.0%~PA-20	
PA-20	PID parameter switchover deviation 2		Default	80.0%
	Setting Range		PA-19~100.0%	

In some applications, PID parameters switchover is required when one group of PID parameters cannot satisfy the requirement of the whole running process.

These parameters are used for switchover between two groups of PID



parameters. Regulator parameters PA-15 to PA-17 are set in the same way as PA-05 to PA-07.

The switchover can be implemented either via a S terminal or automatically implemented based on the deviation.

If you select switchover via a S terminal, the S must be allocated with function 43 "PID parameter switchover". If the DI is OFF, group 1 (PA-05 to PA-07) is selected. If the DI is ON, group 2 (PA-15 to PA-17) is selected.

If you select automatic switchover, when the absolute value of the deviation between PID feedback and PID setting is smaller than the value of PA-19, group 1 is selected. When the absolute value of the deviation between PID feedback and PID setting is higher than the value of PA-20, group 2 is selected. When the deviation is between PA-19 and PA-20, the PID parameters are the linear interpolated value of the two groups of parameter values.

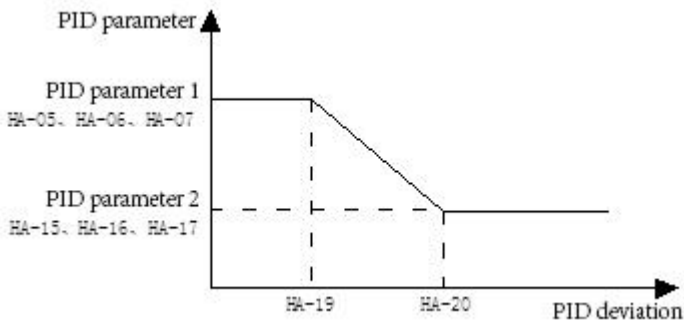

Figure 6-27 PID parameters switchover

PA-21	PID initial value	Default	0.0%
-------	-------------------	---------	------

	Setting Range	0.0%~100.0%	
PA-22	PID initial value holding time	Default	0.00s
	Setting Range	0.00s~650.00s	

When the AC drive starts up, the PID starts closed-loop algorithm only after the PID output is fixed to the PID initial value (PA-21) and lasts the time set in PA-22.

PA-23	Maximum deviation between two PID outputs in forward direction	Default	1.00%
	Setting Range	0.00%~100.00%	
PA-24	Maximum deviation between two PID outputs in reverse direction	Default	1.00%
	Setting Range	0.00%~100.00%	

This function is used to limit the deviation between two PID outputs (2 ms per PID output) to suppress the rapid change of PID output and stabilize the running of the AC drive.

PA-23 and PA-24 respectively correspond to the maximum absolute value of the output deviation in forward direction and in reverse direction.

PA-25	PID integral property		Default	00
	Setting Range	Unit's digit	Integral separated	
		0	Invalid	
		1	Valid	
		Ten's digit	Whether to stop integral operation when the output reaches the limit	
		0	Continue integral operation	
		1	Stop integral operation	

Integral separated

If it is set to valid, the PID integral operation stops when the S allocated with function 22 "PID integral pause" is ON In this case, only proportional and

differential operations take effect.

If it is set to invalid, integral separated remains invalid no matter whether the S allocated with function 22 "PID integral pause" is ON or not. Whether to stop integral operation when the output reaches the limit. If "Stop integral operation" is selected, the PID integral operation stops, which may help to reduce the PID overshoot.

PA-26	Detection value of PID feedback loss	Default	0.0%
	Setting Range	0.0%:Not judging feedback loss 0.1%~100.0%	
PA-27	Detection time of PID feedback loss	Default	1.0s
	Setting Range	0.0s~20.0s	

These parameters are used to judge whether PID feedback is lost.

If the PID feedback is smaller than the value of PA-26 and the lasting time exceeds the value of PA-27, the AC drive reports E031 and acts according to the selected fault protection action.

PA-28	PID operation at stop		Default	0
	Setting Range	0	No PID operation at stop	
		1	PID operation at stop	

It is used to select whether to continue PID operation in the state of stop.

Generally, the PID operation stops when the AC drive stops.

### Group Pb Swing Frequency, Fixed Length and Count

The swing frequency function is applied to the textile and chemical fiber fields and the applications where traversing and winding functions are required.

The swing frequency function indicates that the output frequency of the AC drive swings up and down with the set frequency as the center. The trace of running frequency at the time axis is shown in the following Figure.

The swing amplitude is set in Pb-00 and Pb-01. When Pb-01 is set to 0, the

swing amplitude is 0 and the swing frequency does not take effect.

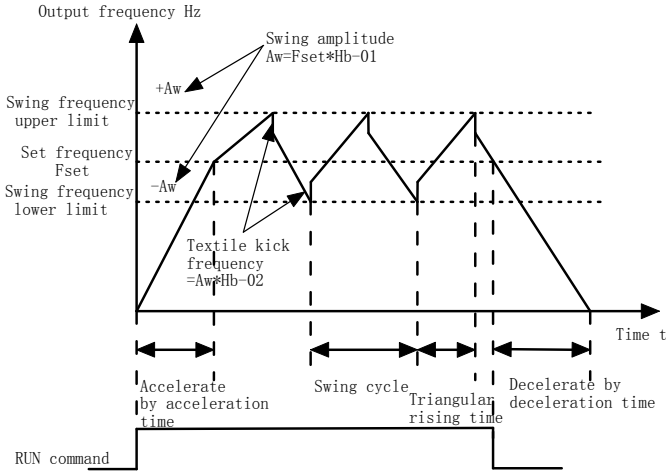

Figure 6-29 Swing frequency control

Pb-00	Swing frequency setting mode		Default	0
	Setting Range	0	Relative to the central frequency	
1		Relative to the maximum frequency		

This parameter is used to select the base value of the swing amplitude.

- 0: Relative to the central frequency (P5-07 frequency source selection)

It is variable swing amplitude system. The swing amplitude varies with the central frequency (set frequency).

- 1: Relative to the maximum frequency (P5-10 maximum output frequency)

It is fixed swing amplitude system. The swing amplitude is fixed.

Pb-01	Swing frequency amplitude	Default	0.0%
	Setting Range	0.0%~100.0%	
Pb-02	Jump frequency amplitude	Default	0.0%

	Setting Range	0.0%~50.0%
--	---------------	------------

This parameter is used to determine the swing amplitude and jump frequency amplitude. The swing frequency is limited by the frequency upper limit and frequency lower limit.

- If relative to the central frequency (Pb-00 = 0), the actual swing amplitude AW is the calculation result of P5-07 (Frequency source selection) multiplied by Pb-01.
- If relative to the maximum frequency (Pb-00 = 1), the actual swing amplitude AW is the calculation result of P5-10 (Maximum frequency) multiplied by Pb-01.

Jump frequency = Swing amplitude AW x Pb-02 (Jump frequency amplitude).

- If relative to the central frequency (Pb-00 = 0), the jump frequency is a variable value.
- If relative to the maximum frequency (Pb-00 = 1), the jump frequency is a fixed value.

The swing frequency is limited by the frequency upper limit and frequency lower limit.

Pb-03	Swing frequency cycle	Default	10.0s
	Setting Range	0.0s~3000.0s	
Pb-04	Triangular wave rising time coefficient	Default	50.0%
	Setting Range	0.0%~100.0%	

Pb-03 specifies the time of a complete swing frequency cycle.

Pb-04 specifies the time percentage of triangular wave rising time to Pb-03 (Swing frequency cycle).

Triangular wave rising time = Pb-03 (Swing frequency cycle) x Pb-04 (Triangular wave rising time coefficient, unit: s)

Triangular wave falling time = Pb-03 (Swing frequency cycle) x (1 - Pb-04

Triangular wave rising time coefficient, unit: s)

Pb-05	Set length	Default	1000m
	Setting Range	0m~65535m	
Pb-06	Actual length	Default	0m
	Setting Range	0m~65535m	
Pb-07	Number of pulses per meter	Default	100.0
	Setting Range	0.1~6553.5	

The preceding parameters are used for fixed length control.

The length information is collected by S terminals. Pb-06 (Actual length) is calculated by dividing the number of pulses collected by the S terminal by Pb-07 (Number of pulses each meter).

When the actual length Pb-06 exceeds the set length in Pb-05, the DO terminal allocated with function 10 (Length reached) becomes ON.

During the fixed length control, the length reset operation can be performed via the S terminal allocated with function 28. For details, see the descriptions of P4-00 to P4-09.

Allocate corresponding S terminal with function 27 (Length count input) in applications. If the pulse frequency is high, S5 must be used.

Pb-08	Set count value	Default	1000
	Setting Range	1~65535	
Pb-09	Designated count value	Default	1000
	Setting Range	1~65535	

The count value needs to be collected by S terminal. Allocate the corresponding S terminal with function 25 (Counter input) in applications. If the pulse frequency is high, S5 must be used.

When the count value reaches the set count value (Pb-08), the DO terminal

allocated with function 8 (Set count value reached) becomes ON. Then the counter stops counting.

When the counting value reaches the designated counting value (Pb-09), the DO terminal allocated with function 9 (Designated count value reached) becomes ON. Then the counter continues to count until the set count value is reached.

Pb-09 should be equal to or smaller than Pb-08.

### Group PC Multi-Reference and Simple PLC Function

The CM540 multi-reference has many functions. Besides multi-speed, it can be used as the setting source of the V/F separated voltage source and setting source of process PID. In addition, the multi-reference is relative value.

Simple PLC can only complete simple combination of multi-reference, while the user programmable function is more practical.

PC-00	Reference 0	Default	0.0%
	Setting Range	-100.0%~100.0%	
PC-01	Reference 1	Default	0.0%
	Setting Range	-100.0%~100.0%	
PC-02	Reference 2	Default	0.0%
	Setting Range	-100.0%~100.0%	
PC-03	Reference 3	Default	0.0%
	Setting Range	-100.0%~100.0%	
PC-04	Reference 4	Default	0.0%
	Setting Range	-100.0%~100.0%	
PC-05	Reference 5	Default	0.0%
	Setting Range	-100.0%~100.0%	

PC-06	Reference 6	Default	0.0%
	Setting Range	-100.0%~100.0%	
PC-07	Reference 7	Default	0.0%
	Setting Range	-100.0%~100.0%	
PC-08	Reference 8	Default	0.0%
	Setting Range	-100.0%~100.0%	
PC-09	Reference 9	Default	0.0%
	Setting Range	-100.0%~100.0%	
PC-10	Reference 10	Default	0.0Hz
	Setting Range	-100.0%~100.0%	
PC-11	Reference 11	Default	0.0%
	Setting Range	-100.0%~100.0%	
PC-12	Reference 12	Default	0.0%
	Setting Range	-100.0%~100.0%	
PC-13	Reference 13	Default	0.0%
	Setting Range	-100.0%~100.0%	
PC-14	Reference 14	Default	0.0%
	Setting Range	-100.0%~100.0%	
PC-15	Reference 15	Default	0.0%
	Setting Range	-100.0%~100.0%	

Multi-reference can be the setting source of frequency, V/F separated voltage and process PID. The multi-reference is relative value and ranges from -100.0% to 100.0%.

As frequency source, it is a percentage relative to the maximum frequency. As V/F separated voltage source, it is a percentage relative to the rated motor voltage. As process PID setting source, it does not require conversion.



Multi-reference can be switched over based on different states of S terminals. For details, see the descriptions of group H4.

PC-16	Simple PLC running mode		Default	0
	Setting Range	0	Stop after the AC drive runs one cycle	
		1	Keep final values after the AC drive runs one cycle	
		2	Repeat after the AC drive runs one cycle	

Simple PLC can be either the frequency source or V/F separated voltage source.

When simple PLC is used as the frequency source, whether parameter values of PC-00 to PC-15 are positive or negative determines the running direction. If the parameter values are negative, it indicates that the AC drive runs in reverse direction.

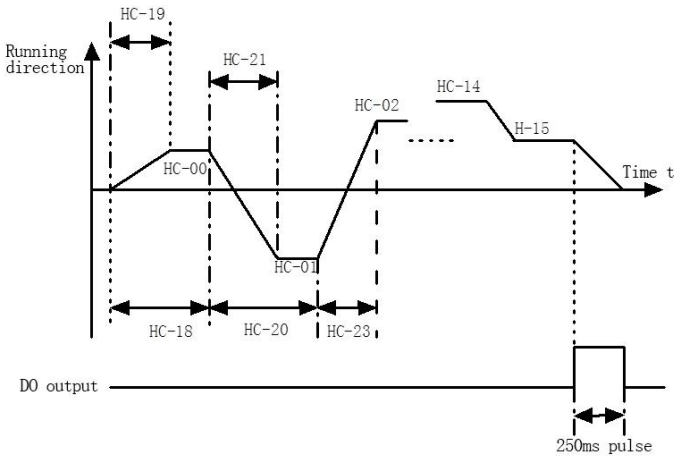

+

Figure 6-31 Simple PIC

**0: Stop after the AC drive runs one cycle**

The AC drive stops after running one cycle, and will not start up until receiving another command.

**1: Keep final values after the AC drive runs one cycle**

The AC drive keeps the final running frequency and direction after running one cycle.

**2: Repeat after the AC drive runs one cycle**

The AC drive automatically starts another cycle after running one cycle, and will not stop until receiving the stop command.

PC-17	Simple PLC retentive selection		Default	00
	Setting Range	Unit's digit	Retentive upon power failure	
		0	No	
		1	Yes	
		Ten's digit	Retentive upon stop	
		0	No	
		1	Yes	

PLC retentive upon power failure indicates that the AC drive memorizes the PLC running moment and running frequency before power failure and will continue to run from the memorized moment after it is powered on again. If the unit's digit is set to 0, the AC drive restarts the PLC process after it is powered on again.

PLC retentive upon stop indicates that the AC drive records the PLC running moment and running frequency upon stop and will continue to run from the recorded moment after it starts up again. If the ten's digit is set to 0, the AC drive restarts the PLC process after it starts up again.

PC-18	Running time of simple PLC reference 0	Default	0.0s ( h )
	Setting Range	0.0s ( h ) ~6553.5s ( h )	
PC-19	Acceleration/deceleration time of simple PLC reference 0	Default	
	Setting Range	0~3	
PC-20	Running time of simple PLC reference 1	Default	0.0s ( h )
	Setting Range	0.0s ( h ) ~6553.5s ( h )	
PC-21	Acceleration/deceleration time of simple PLC reference 1	Default	
	Setting Range	0~3	
PC-22	Running time of simple PLC reference 2	Default	0.0s ( h )
	Setting Range	0.0s ( h ) ~6553.5s ( h )	
PC-23	Acceleration/deceleration time of simple PLC reference 2	Default	
	Setting Range	0~3	
PC-24	Running time of simple PLC reference 3	Default	0.0s ( h )
	Setting Range	0.0s ( h ) ~6553.5s ( h )	
PC-25	Acceleration/deceleration time of simple PLC reference 3	Default	
	Setting Range	0~3	
PC-26	Running time of simple PLC reference 4	Default	0.0s ( h )
	Setting Range	0.0s ( h ) ~6553.5s ( h )	
PC-27	Acceleration/deceleration time of simple PLC reference 4	Default	
	Setting Range	0~3	
PC-28	Running time of simple PLC reference 5	Default	0.0s ( h )
	Setting Range	0.0s ( h ) ~6553.5s ( h )	

PC-29	Acceleration/deceleration time of simple PLC reference 5	Default	
	Setting Range	0~3	
PC-30	Running time of simple PLC reference 6	Default	0.0s ( h )
	Setting Range	0.0s ( h ) ~6553.5s ( h )	
PC-31	Acceleration/deceleration time of simple PLC reference 6	Default	
	Setting Range	0~3	
PC-32	Running time of simple PLC reference 7	Default	0.0s ( h )
	Setting Range	0.0s ( h ) ~6553.5s ( h )	
PC-33	Acceleration/deceleration time of simple PLC reference 7	Default	
	Setting Range	0~3	
PC-34	Running time of simple PLC reference 8	Default	0.0s ( h )
	Setting Range	0.0s ( h ) ~6553.5s ( h )	
PC-35	Acceleration/deceleration time of simple PLC reference 8	Default	
	Setting Range	0~3	
PC-36	Running time of simple PLC reference 9	Default	0.0s ( h )
	Setting Range	0.0s ( h ) ~6553.5s ( h )	
PC-37	Acceleration/deceleration time of simple PLC reference 9	Default	
	Setting Range	0~3	
PC-38	Running time of simple PLC reference 10	Default	0.0s ( h )
	Setting Range	0.0 s ( h ) ~6553.5s ( h )	
PC-39	Acceleration/deceleration time of simple PLC reference 10	Default	
	Setting Range	0~3	

PC-40	Running time of simple PLC reference 11	Default	0.0s ( h )
	Setting Range	0.0s ( h ) ~6553.5s ( h )	
PC-41	Acceleration/deceleration time of simple PLC reference 11	Default	
	Setting Range	0~3	
PC-42	Running time of simple PLC reference 12	Default	0.0s ( h )
	Setting Range	0.0s ( h ) ~6553.5s ( h )	
PC-43	Acceleration/deceleration time of simple PLC reference 12	Default	
	Setting Range	0~3	
PC-44	Running time of simple PLC reference 13	Default	0.0s ( h )
	Setting Range	0.0s ( h ) ~6553.5s ( h )	
PC-45	Acceleration/deceleration time of simple PLC reference 13	Default	
	Setting Range	0~3	
PC-46	Running time of simple PLC reference 14	Default	0.0s ( h )
	Setting Range	0.0s ( h ) ~6553.5s ( h )	
PC-47	Acceleration/deceleration time of simple PLC reference 14	Default	0
	Setting Range	0~3	
PC-48	Running time of simple PLC reference 15	Default	0.0s ( h )
	Setting Range	0.0s ( h ) ~6553.5s ( h )	
PC-49	Acceleration/deceleration time of simple PLC reference 15	Default	0
	Setting Range	0~3	

PC-50	Time unit of simple PLC running	Default	0
	Setting Range	0	S ( second )

		1	h ( hour )
PC-51	Reference 0 source		Default 0
	Setting Range	0	Set by PC-00
		1	AI1
		2	AI2
		3	AI3
		4	HDI Pulse setting
		5	PID
		6	Set by preset frequency (P5-08), modified via terminal UP/DOWN

It determines the setting channel of reference 0. You can perform convenient switchover between the setting channels. When multi-reference or simple PLC is used as frequency source, the switchover between two frequency sources can be realized easily.

**Group PD Communication parameter**

Please check appendix E: CM540 Modbus communication protocol

**PP Group User Password**

PP-00	User password	Default	0
	Setting Range	0~65535	

If it is set to any non-zero number, the password protection function is enabled. After a password has been set and taken effect, you must enter the correct password in order to enter the menu. If the entered password is incorrect you cannot view or modify parameters. If PP-00 is set to 00000, the previously set user password is cleared, and the password protection function is disabled.

PP-01	Restore default settings		Default 0
	Setting Range	0	No operation

		1	Restore factory settings except motor parameters
		2	Clear records
		4	Restore user backup parameters
		5	Back up current user parameters

1: Restore default settings except motor parameters

If PP-01 is set to 1, most function codes are restored to the default settings except motor parameters, frequency reference resolution (P5-22), fault records, accumulative running time (P7-09), accumulative power-on time (P7-13) and accumulative power consumption (P7-14).

2: Clear records

If PP-01 is set to 2, the fault records, accumulative running time (P7-09), accumulative power-on time (P7-13) and accumulative power consumption (P7-14) are cleared.

3: The current parameter settings are backed up, helping you to restore the setting if incorrect parameter setting is performed.

4: Restore user backup parameters

If PP-01 is set to 4, the previous backup user parameters are restored.

	AC drive parameter display property	Default	11
PP-02	Setting Range	Unit's digit	Group d display selection
		0	Not display
		1	Display
		Ten's digit	Group C display selection
		0	Not display
		1	Display
PP-03	Individualized parameter display property	Default	00

Setting Range	Unit's digit	User-defined parameter display selection
	0	Not display
	1	Display (--u--)
	Ten's digit	User-modified parameter display selection
	0	Not display
	1	Display (--c--)

The setting of parameter display mode aims to facilitate you to view different types of parameters based on actual requirements. The CM540 provides the following three parameter display modes.

Table 6-9 Three parameter display modes provided by CM540

Name	parameter display	Description
AC drive parameter display	--H--	Display function codes of the AC drive in sequence of H0 to HF, C0 to CC, D0
User-defined parameter display	--u--	Display a maximum of 32 user-defined parameters included in group HE.
User-modified parameter display	--c--	Display the parameters that are modified.

The CM540 provides display of two types of individualized parameters: user-defined parameters and user-modified parameters.

You-defined parameters are included in group HE. You can add a maximum of 32 parameters, convenient for commissioning.

In user-defined parameter mode, symbol "u" is added before the function code. For example, P1-00 is displayed as uP1-00.

You-modified parameters are grouped together, convenient for on-site troubleshooting.

In you-modified parameter mode, symbol "c" is added before the function code.



For example, F1-00 is displayed as cP1-00.

PP-04	Parameter modification property		Default	0
	Setting Range	0	Modifiable	
		1	Not modifiable	

It is used to set whether the parameters are modifiable to avoid mal-function. If it is set to 0, all parameters are modifiable. If it is set to 1, all parameters can only be viewed.

### Group H0: Torque Control and Restricting Parameters

H0-00	Speed/Torque control selection		Default	0
	Setting range	0	Speed control	
		1	Torque control	

It is used to select the AC drive's control mode: speed control or torque control.

The CM540 provides DI terminals with two torque related functions, function 29 (Torque control prohibited) and function 46 (Speed control/Torque control switchover). The two DI terminals need to be used together with H0-00 to implement speed control/torque control switchover.

If the S terminal allocated with function 46 (Speed control/Torque control switchover) is OFF, the control mode is determined by H0-00. If the DI terminal allocated with function 46 is ON, the control mode is reverse to the value of H0-00.

However, if the S terminal with function 29 (Torque control prohibited) is ON, the AC drive is fixed to run in the speed control mode.

H0-01	Torque setting source in torque control		Default	0
	Setting Range	0	Digital setting ( H0-03 )	

		1	AI1	
		2	AI2	
		3	AI3	
		4	HDI Pulse setting (S5 terminal)	
		5	Communication setting	
		6	MIN ( AI1,AI2 )	
		7	MAX ( AI1,AI2 )	
H0-03	Torque digital setting in torque control		Default	0
	Setting Range		-200.0%~200.0%	

H0-01 is used to set the torque setting source. There are a total of eight torque setting sources. The torque setting is a relative value. 100.0% corresponds to the AC drive's rated torque. The setting range is -200.0% to 200.0%, indicating the AC drive's maximum torque is twice of the AC drive's rated torque.

When the torque setting use 1~7, the communication and analog input and pulse input is 100% corresponds to H0-03.

H0-05	Forward maximum frequency in torque control	Default	50.00Hz
	Setting Range	0.00Hz~maximum frequency (P5-10)	
H0-06	Reverse maximum frequency in torque control	Default	50.00Hz
	Setting Range	0.00Hz~maximum frequency (P5-10)	

Two parameters are used to set the maximum frequency in forward or reverse rotation in torque control mode.

In torque control, if the load torque is smaller than the motor output torque, the motor's rotational speed will rise continuously. To avoid runaway of the

mechanical system, the motor maximum rotating speed must be limited in torque control.

H0-07	Acceleration time in torque control	Default	0.00s
	Setting Range	0.00s~65000s	
H0-08	Deceleration time in torque control	Default	0.00s
	Setting Range	0.00s~65000s	

In torque control, the difference between the motor output torque and the load torque determines the speed change rate of the motor and load. The motor rotational speed may change quickly and this will result in noise or too large mechanical stress. The setting of acceleration/deceleration time in torque control makes the motor rotational speed change softly.

However, in applications requiring rapid torque response, set the acceleration/deceleration time in torque control to 0.00s. For example, two AC drives are connected to drive the same load. To balance the load allocation, set one AC drive as master in speed control and the other as slave in torque control. The slave receives the master's output torque as the torque command and must follow the master rapidly. In this case, the acceleration/deceleration time of the slave in torque control is set to 0.0s.

#### Group H1: Virtual Input (XS)/Virtual Output (XDO)

H1-00	Virtual XDI1 terminal function selection	Default	0
	Setting Range	0~59	
H1-01	Virtual XDI2 terminal function selection	Default	0
	Setting Range	0~59	
H1-02	Virtual XDI3 terminal function selection	Default	0
	Setting Range	0~59	
H1-03	Virtual XDI4 terminal function selection	Default	0
	Setting Range	0~59	

H1-04	Virtual XDI5 terminal function selection	Default	0
	Setting Range		0~59

XS1 to XS5 have the same functions as S terminals on the control board and can be used for digital input. For more details, see description of P4-00 to P4-09.

H1-05	Virtual V input terminal state setting mode		Default	00000
	Setting Range	Unit's digit	Virtual XDI1	
		0	Decided by state of XDOx	
		1	Decided by H1-06	
		Ten's digit	Virtual XDI2 (0~1, same as above)	
		Hundred's digit	Virtual XDI3 (0~1, same as above)	
		Thousand's digit	Virtual XDI4 (0~1, same as above)	
		Ten thousand's digit	Virtual XDI5 (0~1, same as above)	
H1-06	Virtual V input terminal state setting		Default	00000
	Setting Range	Unit's digit	Virtual XDI1	
		0	Invalid	
		1	Valid	
		Ten's digit	Virtual XDI2 (0~1, same as above)	
		Hundred's digit	Virtual XDI3 (0~1, same as above)	
		Thousand's digit	Virtual XDI4 (0~1, same as above)	
		Ten thousand's digit	Virtual XDI5 (0~1, same as above)	

Different from digital input terminals, XDI state can be set in two modes, selected in H1-05:

### Decided by state of XDO

Whether the state a XDI is valid is determined by the state of the corresponding XDO and XDI is uniquely bound to XDO x (x is between 1 and 6). For example, to implement the function that the AC drive reports an alarm and stops when the input exceeds the limit, perform the following setting:

- 1) Allocate XDI with function 44 "User-defined fault 1" (H1-00 = 44).
- 2) Set H1-05 to xxx0.
- 3) Allocate XVDO1 with function 31 "AI1 input limit exceeded" (H1-11 = 31).

When the AI1 input exceeds the limit, XDO1 becomes ON. At this moment, XDI becomes ON and the AC drive receives you-defined fault 1. Then the AC drive reports E027 and stops.

### Decided by H1-06

The XDI state is determined by the binary bit of H1-06. For example, to implement the function that the AC drive automatically enters the running state after power-on, perform the following setting:

- 1) Allocate XDI1 with function 1 "Forward RUN (FWD)" (H1-00 = 1).
- 2) Set H1-05 to xxx1: The state of XS1 is decided by H1-06.
- 3) Set H1-06 to xxx1: XDI1 is valid.
- 4) Set P5-02 to 1: The command source to terminal control.
- 5) Set P8-18 to 0: Startup protection is not enabled.

When the AC drive completes initialization after power-on, it detects that XS1 is valid and allocated with the function of forward RUN. That is, the AC drive receives the forward RUN command from the terminal. Therefore, The AC drive starts to run in forward direction.

H1-07	Function selection for AI1 used as S	Default	0
	Setting Range	0~59	
H1-08	Function selection for AI2 used as S	Default	0

	Setting Range	0~59	
H1-09	Function selection for AI3 used as S	Default	0
	Setting Range	0~59	
H1-10	State selection for V used as S	Default	0
	Setting Range	Unit's digit	AI1
		0	High level valid
		1	Low level valid
		Ten's digit	AI2 (0~1 , same as unit's digit)
Hundred's digit	AI3 (0~1 , same as unit's digit)		

The functions of these parameters are to use V as DI. When V is used as DI, the V state is high level if the V input voltage is 7 V or higher and is low level if the V input voltage is 3 V or lower. The V state is hysteresis if the V input voltage is between 3 V and 7 V. H1-10 is used to determine whether high level valid or low level valid when V is used as S. The setting function is the same as that of Ss. For details, see the descriptions of group H4.

The following Figure takes input voltage as an example to describe the relationship between AI input voltage and corresponding S state.

Figure 6-32 Relationship of AI input voltage and corresponding S status :

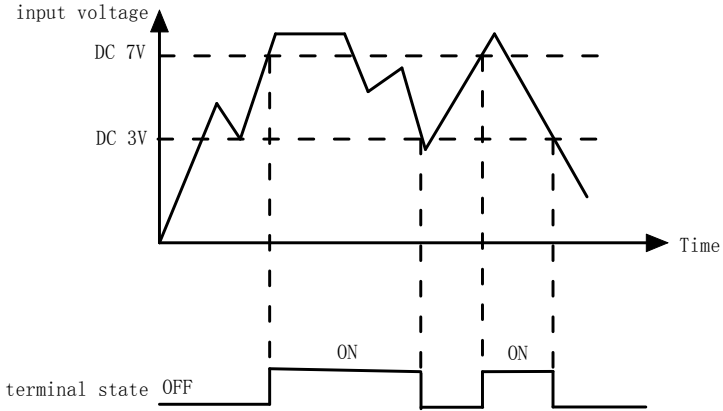

Figure 6-32 The valid status judgment of AI as DI

H1-11	XDO1 function selection	Default	0
	Setting Range	0:Short with physical Sx internally 1~40:Refer to function selection of physical DO in group H5	
H1-12	XDO2 function selection	Default	0
	Setting Range	0:Short with physical Sx internally 1~40:Refer to function selection of physical DO in group H5	
H1-13	XDO3 function selection	Default	0
	Setting Range	0:Short with physical Sx internally 1~40:Refer to function selection of physical DO in group H5	
H1-14	XDO4 function selection	Default	0
	Setting Range	0:Short with physical Sx internally 1~40:Refer to function selection of physical DO in group H5	
H1-15	XDO5 function selection	Default	0
	Setting Range	0:Short with physical Sx internally 1~40:Refer to function selection of physical DO in group H5	
H1-16	XDO1 output delay	Default	0.0s

	Setting Range	0.0s~3600.0s	
H1--17	XDO2 output delay	Default	0.0s
	Setting Range	0.0s~3600.0s	
H1-18	XDO3 output delay	Default	0.0s
	Setting Range	0.0s~3600.0s	
H1-19	XDO4 output delay	Default	0.0s
	Setting Range	0.0s~3600.0s	
H1-20	XDO5 output delay	Default	0.0s
	Setting Range	0.0s~3600.0s	
H1-21	XDO state selection	Default	00000
	Setting Range	Unit's digit	XDO1
		0	Positive logic
		1	Reverse logic
		Ten's digit	XDO2 ( 0~1 , same as unit's digit )
		Hundred's digit	XDO3 ( 0~1 , same as unit's digit )
		Thousand's digit	XDO4 ( 0~1 , same as unit's digit )
		Ten thousand's digit	XDO5 ( 0~1 , same as unit's digit )

These functions are similar to the DO functions on the control board and can be used together with XSx to implement some simple logic control.

If XDOx function is set to 0, the state of XDOx 1 to XDOx 5 is determined by the state of S1 to S5 on the control board. In this case, XDOx and Sx are one-to-one mapping relationship.

If XDOx function is set to non-0, the function setting and use of XDOx are the same as DO in group H5.



The XDOx state can be set in H1-21. The application examples of XSx involve the use of XDOx, and see the examples for your reference.

## Group H2 Motor 2 Parameters

The CM540 can switch over the running among 2 motors. For the 2 motors, you can:

- Set motor nameplate parameters respectively
- Perform motor parameter auto-tuning respectively
- Select V/F control or vector control respectively
- Set encoder-related parameters respectively
- Set parameters related to V/F control or vector control independently

Groups C2 respectively correspond to motor 2. The parameters of the three groups are the same. Here we just list the parameters of group C2 for reference.

All parameters in group A2 have the same definition and usage as parameters of motor 1. For more details, refer to the descriptions of motor 1 parameters.

H2-00	Motor selection		Default	0
	Setting Range	0	Common asynchronous motor	
		1	Variable frequency asynchronous motor	
		2	Permanent magnetic synchronous motor	
H2-01	Rated motor power		Default	Model dependent
	Setting Range		0.1kW~1000.0kW	

H2-02	Rated motor voltage	Default	Model dependent
	Setting Range	1V~2000V	
H2-03	Rated motor current	Default	Model dependent
	Setting Range	0.01A~655.35A ( AC drive power <=55kW ) 0.1A~6553.5A ( AC drive power >55kW )	
H2-04	Rated motor frequency	Default	Model dependent
	Setting Range	0.01Hz~maximum frequency	
H2-05	Rated motor rotational speed	Default	Model dependent
	Setting Range	1rpm~65535rpm	
H2-06	Stator resistance (asynchronous motor)	Default	Model dependent
	Setting Range	0.001Ω~65.535Ω ( AC drive power <=55kW ) 0.0001Ω~6.5535Ω ( AC drive power >55kW )	
H2-07	Rotor resistance (asynchronous motor)	Default	Model dependent
	Setting Range	0.001Ω~65.535Ω ( AC drive power <=55kW )	
H2-08	Leakage inductive Reactance (asynchronous motor)	Default	Model dependent
	Setting Range	0.01mH~655.35mH ( AC drive power <=55kW )	
H2-09	Mutual inductive reactance (asynchronous motor)	Default	Model dependent
	Setting Range	0.1mH~6553.5mH ( AC drive power <=55kW )	
H2-10	No-load current (asynchronous motor)	Default	Model dependent
	Setting Range	0.01A~H2-03 ( AC drive power <=55kW )	
H2-16	Stator resistance (synchronous motor)	Default	Model dependent

	Setting Range	0.001Ω~65.535Ω (AC drive power ≤55kW) 0.0001Ω~6.5535Ω (AC drive power >55kW)	
H2-17	Shaft D inductance (synchronous motor)	Default	Model dependent
	Setting Range	0.01mH~655.35mH ( AC drive power ≤55kW )	
H2-18	Shaft Q inductance (synchronous motor)	Default	Model dependent
	Setting Range	0.01mH~655.35mH ( AC drive power ≤55kW )	
H2-20	Back EMF (synchronous motor)	Default	Model dependent
	Setting Range	0.1V~6553.5V	
H2-27	Encoder pulses perrevolution	Default	1024
	Setting Range	1~65535	
H2-28	Encoder type	Default	0
	Setting Range	0	ABZ incremental encoder
		1	UVW incremental encoder
		2	Resolver
		3	SIN/COS encoder
		4	Wire-saving UVW encoder
H2-29	Speed feedback PG section	Default	0
	Setting Range	0	local PG
		1	Extend PG
		2	HDI pulse input ( S5 )
H2-30	A, B phase sequence of ABZ incremental encoder	Default	0
	Setting Range	0	Forward
		1	Reserve

H2-31	Encoder installation angle		Default	0
	Setting Range		0.0°~359.9°	
H2-32 ~ H2-35	Retain			
H2-36	Speed feedback PG wire-break fault detection time		Default	0.0s
	Setting Range		0.0:No action 0.1s~10.0s	
H2-37	Auto-tuning selection		Default	0
	Setting Range	0	No auto-tuning	
		1	Asynchronous motor static auto-tuning	
		2	Asynchronous motor complete auto-tuning	
		11	Synchronous motor with-load auto-tuning	
	12	Synchronous motor no-load auto-tuning		
H2-38	Speed loop proportional gain 1		Default	30
	Setting Range		1~100	
H2-39	Speed loop integral time 1		Default	0.50s
	Setting Range		0.01s~10.00s	
H2-40	Switchover frequency 1		Default	5.00Hz
	Setting Range		0.00~H2-43	
H2-41	Speed loop proportional gain 2		Default	15
	Setting Range		0~100	
H2-42	Speed loop integral time 2		Default	1.00s
	Setting Range		0.01s~10.00s	
H2-43	Switchover frequency 2		Default	10.00Hz
	Setting Range		H2-40 to maximum output frequency	

H2-44	Vector control slip gain		Default	100%
	Setting Range		50%~200%	
H2-45	Time constant of speed loop filter		Default	0.000s
	Setting Range		0.000s~0.100s	
H2-46	Vector control over-excitation gain		Default	64
	Setting Range		0~200	
H2-47	Torque upper limit source in speed control mode		Default	0
	Setting Range	0	H2-48 setting	
		1	AI1	
		2	AI2	
		3	AI3	
		4	HDI setting	
		5	Communication setting	
		6	MIN ( AI1,AI2 )	
		7	MAX ( AI1,AI2 )	
H2-48	Digital setting of torque upper limit in speed control mode		Default	150.0%
	Setting Range		0.0%~200.0%	
H2-51	Excitation adjustment proportional gain		Default	2000
	Setting Range		0~20000	
H2-52	Excitation adjustment integral gain		Default	1300
	Setting Range		0~20000	
H2-53	Torque adjustment proportional gain		Default	2000
	Setting Range		0~20000	

H2-54	Torque adjustment integral gain		Default	1300
	Setting Range		0~20000	
H2-55	Speed loop integral property		Default	0
	Setting Range		Unit's digit: Integral separated 0:Disabled , 1:Enabled	
H2-56	Field weakening mode of synchronous motor		Default	0
	Setting Range	0	No field weakening	
		1	Direct calculation	
		2	Adjustment	
H2-57	Field weakening degree of synchronous motor		Default	100%
	Setting Range		50%~500%	
H2-58	Maximum field weakening current		Default	50%
	Setting Range		1%~300%	
H2-59	Field weakening automatic adjustment gain		Default	100%
	Setting Range		10%~500%	
H2-60	Field weakening integral multiple		Default	2
	Setting Range		2~10	
H2-61	Motor 2 control mode		Default	0
	Setting Range	0	Sensorless flux vector control ( SVC )	
		1	Closed-loop vector control ( FVC )	
2		Voltage/Frequency (V/F) control		
H2-62	Motor 2 acceleration/ deceleration time		Default	0
	Setting Range	0	Same as motor 1	
		1	Acceleration/Deceleration time 1	

		2	Acceleration/Deceleration time 2	
		3	Acceleration/Deceleration time 3	
		4	Acceleration/Deceleration time 4	
H2-63	Motor 2 torque boost		Default	Model dependent
	Setting Range		0.0%:Automatic torque boost 0.1%~30.0%	
H2-65	Motor 2 oscillation suppression gain		Default	Model dependent
	Setting Range		0~100	

### Group H5 Control Optimization Parameters

H5-00	DPWM switchover frequency upper limit		Default	12.00Hz
	Setting Range		0.00Hz~15Hz	

This parameter is valid only for V/F control.

It is used to determine the wave modulation mode in V/F control of asynchronous motor. If the frequency is lower than the value of this parameter, the waveform is 7-segment continuous modulation. If the frequency is higher than the value of this parameter, the waveform is 5-segment intermittent modulation.

The 7-segment continuous modulation causes more loss to switches of the AC drive but smaller current ripple. The 5-segment intermittent modulation causes less loss to switches of the AC drive but larger current ripple. This may lead to motor running instability at high frequency. Do not modify this parameter generally.

For instability of V/F control, refer to parameter P3-11. For loss to AC drive and temperature rise, refer to parameter P5-15.

H5-01	PWM modulation mode		Default	0
	Setting Range	0	Asynchronous modulation	

		1	Synchronous modulation
--	--	---	------------------------

This parameter is valid only for V/F control.

Synchronous modulation indicates that the carrier frequency varies linearly with the change of the output frequency, ensuring that the ratio of carrier frequency to output frequency remains unchanged. Synchronous modulation is generally used at high output frequency, which helps improve the output voltage quality.

At low output frequency (100 Hz or lower), synchronous modulation is not required. This is because asynchronous modulation is preferred when the ratio of carrier frequency to output frequency is high.

Synchronous modulation takes effect only when the running frequency is higher than 85 Hz. If the frequency is lower than 85 Hz, asynchronous modulation is always used.

H5-02	Dead zone compensation mode selection		Default	1
	Setting Range	0	No compensation	
		1	Compensation mode 1	
		2	Compensation mode 2	

Generally, you need not modify this parameter. Try to use a different compensation mode only when there is special requirement on the output voltage waveform quality or oscillation occurs on the motor.

For high power AC drive, compensation mode 2 is recommended.

H5-03	Random PWM depth		Default	0
	Setting Range	0	Random PWM invalid	
		1~10	PWM carrier random deep	

The setting of random PWM depth can make the shrill motor noise softer and reduce the electromagnetic interference. If this parameter is set to 0, random PWM is invalid.

H5-04	Rapid current limit	Default	1
-------	---------------------	---------	---



	Setting	0	Disabled
	Range	1	Enabled

The rapid current limit function can reduce the AC drive's over current faults at maximum, guaranteeing uninterrupted running of the AC drive.

However, long-time rapid current limit may cause the AC drive to overheat, which is not allowed. In this case, the AC drive will report E040, indicating the AC drive is overloaded and needs to stop.

H5-05	Current detection compensation	Default	5
	Setting Range	0~100	

It is used to set the AC drive current detection compensation. Too large value may lead to deterioration of control performance. Do not modify it generally.

H5-06	Under-voltage threshold	Default	100.0%
	Setting Range	60.0%~140.0%	

It is used to set the under-voltage threshold of E009. The under-voltage threshold 100% of the AC drive of different voltage classes corresponds to different nominal values, as listed in the following table.

H5-07	SVC optimization mode selection		1
	Setting Range	0	No optimization
		1	Optimization mode 1
		2	Optimization mode 2

1: Optimization mode 1

It is used when the requirement on torque control linearity is high.

2: Optimization mode 2

It is used for the requirement on speed stability is high.

H5-08	Dead-zone time adjustment	Default	150%
	Setting Range	100%~200%	

It is only valid for 1140 V voltage class.

You can modify the value of this parameter to improve the voltage utilization rate.

Too small value may system instability. Do not modify it generally.

### Group P6 Curve Setting

H6-00	curve 4 minimum input	Default	0.00V
	Setting Range	-10.00V~H6-02	
H6-01	Corresponding setting of curve 4 minimum input	Default	0.0%
	Setting Range	-100.0%~100.0%	
H6-02	curve 4 inflexion 1 input	Default	3.00V
	Setting Range	H6-00~H6-04	
H6-03	Corresponding setting of curve 4 inflexion 1 input	Default	30.0%
	Setting Range	-100.0%~100.0%	
H6-04	curve 4 inflexion 2 input	Default	6.00V
	Setting Range	H6-02~H6-06	
H6-05	Corresponding setting of curve 4 inflexion 2 input	Default	60.0%
	Setting Range	-100.0%~100.0%	
H6-06	curve 4 maximum input	Default	10.00V
	Setting Range	H6-06~10.00V	
H6-07	Corresponding setting of curve 4 maximum input	Default	100.0%
	Setting Range	-100.0%~100.0%	
H6-08	curve 4 minimum input	Default	0.00V
	Setting Range	-10.00V~H6-10	

H6-09	Corresponding setting of curve 5 minimum input	Default	0.0%
	Setting Range	-100.0%~100.0%	
H6-10	curve 5 inflexion 1 input	Default	3.00V
	Setting Range	H6-08~H6-12	
H6-11	Corresponding setting of curve 5 inflexion 1 input	Default	30.0%
	Setting Range	-100.0%~100.0%	
H6-12	curve 5 inflexion 2 input	Default	6.00V
	Setting Range	H6-10~H6-14	
H6-13	Corresponding setting of curve 5 inflexion2 input	Default	60.0%
	Setting Range	-100.0%~100.0%	
H6-14	curve 5 maximum input	Default	10.00V
	Setting Range	H6-14~10.00V	
H6-15	Corresponding setting of curve 5 maximum input	Default	100.0%
	Setting Range	-100.0%~100.0%	

The function of curve 4 and curve 5 is similar to that curve 1 to curve 3, but curve 1 to curve 3 are lines, and curve 4 and curve 5 are 4-point curves, implementing more flexible corresponding relationship. The schematic diagram of curve 4 and curve 5 is shown in the wing Figure.

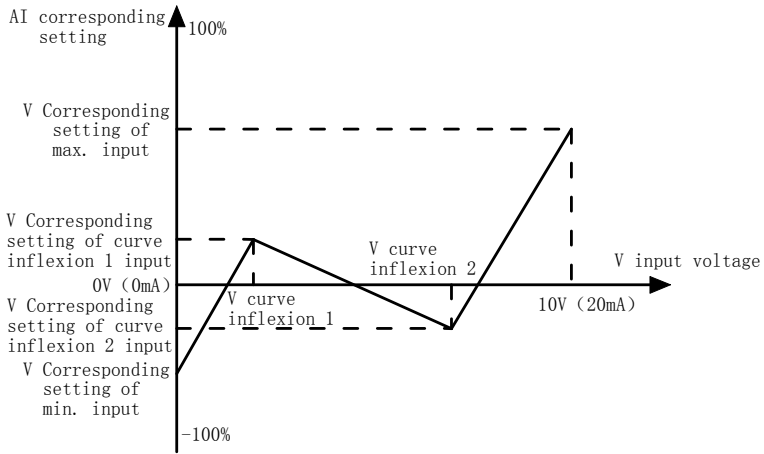

Figure 6-33 Schematic diagram curve 4 and curve 5

When setting curve 4 and curve 5, note that the curve's minimum input voltage, inflexion 1 voltage, inflexion 2 voltage and maximum voltage must be in increment order.

P4-34 (AI curve selection) is used to select curve for AI1 to AI3.

H6-16	AI1 setting Jump point	Default	0.0 %
	Setting Range	-100.0%~100.0%	
H6-17	AI1 setting Jump amplitude	Default	0.5 %
	Setting Range	0.0%~100.0%	
H6-18	AI2 setting Jump point	Default	0.0 %
	Setting Range	-100.0%~100.0%	
H6-19	AI2 setting Jump amplitude	Default	0.5 %
	Setting Range	0.0%~100.0%	
H6-20	AI3 setting Jump point	Default	0.0 %
	Setting Range	-100.0%~100.0%	
H6-21	AI3 setting Jump amplitude	Default	0.5 %
	Setting Range	0.0%~100.0%	

The terminals (AI1 to AI3) of the CM540 all support the corresponding setting jump function, which fixes the V input corresponding setting at the jump point when V input corresponding setting jumps around the jump range.

For example, AI1 input voltage jumps around 5.00 V and the jump range is 4.90–5.10 V. AI1 minimum input 0.00 V corresponds to 0.0% and maximum input 10.00 V corresponds to 100.0%. The detected AI1 input corresponding setting varies between 49.0% and 51.0%.

If you set H6-16 to 50.0% and H6-17 to 1.0%, then the obtained AI1 input corresponding setting is fixed to 50.0%, eliminating the fluctuation effect.

### Group HC Analog Correction

HC-00	AI1 measured voltage 1	Default	Factory-corrected
	Setting Range	0.500V~4.000V	
HC-01	AI1 displayed voltage 1	Default	Factory-corrected
	Setting Range	0.500V~4.000V	
HC-02	AI1 measured voltage 2	Default	Factory-corrected
	Setting Range	6.000V~9.999V	
HC-03	AI1 displayed voltage 2	Default	Factory-corrected
	Setting Range	6.000V~9.999V	
HC-04	AI2 measured voltage 1	Default	Factory-corrected
	Setting Range	0.500V~4.000V	
HC-05	AI2 displayed voltage 1	Default	Factory-corrected
	Setting Range	0.500V~4.000V	
HC-06	AI2 measured voltage 2	Default	Factory-corrected
	Setting Range	6.000V~9.999V	
HC-07	AI2 displayed voltage 2	Default	Factory-corrected
	Setting Range	-9.999V~10.000V	
HC-08	AI3 measured voltage 1	Default	Factory-corrected
	Setting Range	-9.999V~10.000V	
HC-09	AI3 displayed voltage 1	Default	Factory-corrected
	Setting Range	-9.999V~10.000V	
HC-10	AI3 measured voltage 2	Default	Factory-corrected
	Setting Range	-9.999V~10.000V	
HC-11	AI3 displayed voltage 2	Default	Factory-corrected
	Setting Range	-9.999V~10.000V	

These parameters are used to correct the AI to eliminate the impact of AI zero offset and gain. They have been corrected upon delivery. When you resume the factory values, these parameters will be restored to the factory-corrected values. Generally, you need not perform correction in the applications.

Measured voltage indicates the actual output voltage value measured by instruments such as the multimeter. Displayed voltage indicates the voltage display value sampled by the AC drive. For details, refer to U0-21, U0-22 and U0-23.

During correction, send two voltage values to each AI terminal, and save the measured values and displayed values to the function codes HC-00 to HC-11. Then the AC drive will automatically perform AI zero offset and gain correction.

If the input voltage and the actual voltage sampled by the AC drive are inconsistent, perform correction on site. Take AI1 as an example. The on-site correction is as follows:

- 1) Send a voltage signal (approximately 2 V) to AI1.
- 2) Measure the AI1 voltage and save it to HC-00.
- 3) View the displayed value of U0-21 and save the value to HC-01.
- 4) Send a voltage signal (approximately 8 V) to AI1.
- 5) Measure AI1 voltage and save it to HC-02.
- 6) View the displayed value of U0-21 and save the value to HC-03.

At correction of AI2 and AI3, the actually sampled voltage is respectively queried in U0-22 and U0-23.

For AI1 and AI2, 2 V and 8 V are suggested as the correction voltages. For AI3, -8 V and 8 V are suggested.

HC-12	AO1 target voltage 1	Default	Factory-corrected
	Setting Range	0.500V~4.000V	
HC-13	AO1 measured voltage 1	Default	Factory-corrected
	Setting Range	0.500V~4.000V	

HC-14	AO1 target voltage 2	Default	Factory-corrected
	Setting Range	6.000V~9.999V	
HC-15	AO1 measured voltage 2	Default	Factory-corrected
	Setting Range	6.000V~9.999V	
HC-16	AO2 target voltage1	Default	Factory-corrected
	Setting Range	0.500V~4.000V	
HC-17	AO2 measured voltage 1	Default	Factory-corrected
	Setting Range	0.500V~4.000V	
HC-18	AO2 target voltage 2	Default	Factory-corrected
	Setting Range	6.000V~9.999V	
HC-19	AO2 measured voltage 2	Default	Factory-corrected
	Setting Range	6.000V~9.999V	

These parameters are used to correct the AO. They have been corrected upon delivery. When you resume the factory values, these parameters will be restored to the factory-corrected values. You need not perform correction in the applications.

Target voltage indicates the theoretical output voltage of the AC drive. Measured voltage indicates the actual output voltage value measured by instruments such as the multimeter.

### Group U0 Monitoring Parameters

Group U0 is used to monitor the AC drive's running state. You can view the parameter values by using operation panel, convenient for on-site commissioning, or from the host computer by means of communication (address: 0x7000-0x7044).

U0-00 to U0-31 are the monitoring parameters in the running and stop state defined by P7- 03 and P7-04. For more details, see Table 5-2.

Function Code	Parameter Name	Minimum unit	Remark
Group d0: Basic Monitoring Parameters			
U0-00	Running frequency (Hz)	0.01Hz	P0-22=1, 0.1HZ P0-22=2, 0.01HZ
U0-01	Set frequency (Hz)	0.01Hz	P0-22=1, 0.1HZ P0-22=2, 0.01HZ
U0-02	Bus voltage (V)	0.1V	
U0-03	Output voltage (V)	1V	
U0-04	Output current (A)	0.01A	0.0A~655.35A(inverter power<=55KW) 0.0A~6553.5A(inverter power >55KW)
U0-05	Output power (kW)	0.1kW	
U0-06	Output torque (%)	0.1%	
U0-07	DI terminal input state	1	Binary number display 1 means corresponding terminal input valid BIT0~BIT7 is corresponding to S1~S8; BIT10~BIT14 is corresponding to VS1~VS5;
U0-08	DO terminal output state	1	Binary number display 1 means corresponding terminal input valid BIT0:SP1 BIT1:relay 1 (TA-TB-TC) BIT2:relay 2 (TA2-TB2-TC2) BIT3:SP2 BIT4:relay 3 (TA3-TB3-TC3) BIT5~BIT9 is corresponding to XD01~XD05;
U0-09	AI1voltage ( V )	0.01V	
U0-10	AI2 voltage ( V )	0.01V	
U0-11	AI3voltage ( V )	0.01V	
U0-12	count value	1	



U0-13	Load speed	1	
U0-14	Load speed display	1	Show value, please check P7-12
U0-15	PID setting	1	PID setting (percentage)*PA-04
U0-16	PID feedback	1	PID feedback ( percentage ) *PA-04
U0-17	PLC stage	1	
U0-18	HDI Input pulse frequency (Hz)	0.01kHz	
U0-19	Feedback speed ( unit 0.01Hz )	0.01Hz	Display the real output frequency of inverter P5-22=1, 0.1HZ P5-22=2, 0.01HZ
U0-20	Remaining running time	0.1Min	Timing operation, please check F8-42~F8-44
U0-21	AI1 voltage before correction	0.001V	
U0-22	AI2 voltage before correction	0.001V	
U0-23	AI3 voltage before correction	0.001V	
U0-24	Linear speed	1m/Min	It displays the linear speed of the DI5 high-speed pulse sampling. The unit is meter/minute. The linear speed is obtained according to the actual number of pulses sampled per minute and FB-07 (Number of pulses per meter).
U0-25	Current power on time	1Min	
U0-26	Current running time	0.1Min	
U0-27	HDI Pulse input frequency	1Hz	
U0-28	Communication setting value	0.01%	It displays the data written by means of the communication address 0x1000.

U0-29	Encoder feedback speed	0.01Hz	It displays the motor running frequency measured by the encoder. P5-22=1, 0.1HZ P5-22=2, 0.01HZ
U0-30	Main frequency	0.01Hz	
U0-31	Auxiliary frequency B	0.01Hz	
U0-32	Check any internal address value	1	
U0-33	Synchronous motor rotor position	0.1°	
U0-34	Motor temperature	1°C	It displays the motor temperature obtained by means of AI3 sampling. For the motor temperature detection, see P9-56
U0-35	Target torque ( % )	0.1%	
U0-36	Resolver position	1	
U0-37	Power factor angle	0.1°	
U0-38	ABZ position	1	It displays the phase A and B pulse counting of the current ABZ or UVW encoder. This value is four times the number of pulses that the encoder runs. For example, if the display is 4000, the actual number of pulses that the encoder runs is 4000/4 = 1000. The value increase when the encoder rotates in forward direction and decreases when the encoder rotates in reverse direction. After increasing to 65535, the value starts to increase from 0 again. After decreasing to 0, the value starts to decrease from 65535 again. You can check whether the installation of the encoder is normal.

U0-39	Target voltage upon V/F separation	1V	
U0-40	Output voltage upon V/F separation	1V	
U0-41	DI terminal input state visual display	1	See diagram 6-34
U0-42	DO terminal input state visual display	1	See diagram 6-35
U0-43	DI function state visual display 1 (function 01- function 40)	1	
U0-44	DI function state visual display 2 (function 41- function 80)	1	
U0-45	Retain		
U0-58	Retain		
U0-59	set frequency ( % )	0.01%	It displays the current set frequency and running frequency. 100.00% corresponds to the AC drive's maximum frequency P5-10).
U0-60	running frequency ( % )	0.01%	It displays the current set frequency and running frequency. 100.00% corresponds to the AC drive's maximum frequency P5-10).
U0-61	AC drive running state	1	
U0-62	Current fault code	1	
U0-63	Retain	-	
U0-64	Retain	-	
U0-65	Torque upper limit	0.01%	

Input terminal state and means:

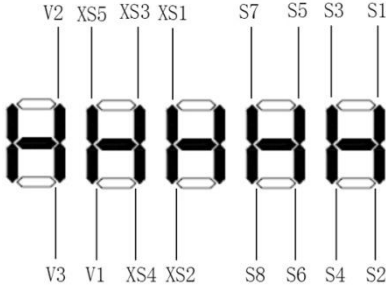

Display corresponding input terminal:  
the display tube bright means input valid

Diagram 6-34 Multifunction input terminal valid input diagram

Output terminal state and means::

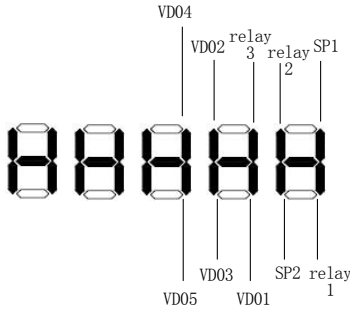

display corresponding output terminal:  
the display tube bright means output valid

Diagram 6-35 output terminal output valid



## Chapter 7 EMC ( Electromagnetic Compatibility )

### 7.1 Definition

EMC is that the electrical equipment is operating in the environment with electromagnetic interference, does not interfere electromagnetic environment and stably achieve its function.

### 7.2 EMC Standard Introduction

According to the requirements of national standard GB/T12668.3, the drive need to comply with electromagnetic interference and anti-electromagnetic interference two requirements. The existing products of the company execute the latest international standards: IEC/EN61800-3:2004 ( Adjustable speed electric SVFI power drive systems-part 3:EMC Requirements and specific test methods) which is equivalent to the national standard GB/T12668.3.

IEC/EN61800-3 inspects the drive from EMI and anti-EMI two aspects, EMI mainly tests the drive's radiation, conducted and harmonic interferences ( Corresponding the civil drive has the requirement ). Anti-EMI mainly tests the drive's conducted immunity, radiation immunity, surge immunity, fast mutant burst immunity,ESD immunity and power low frequency end immunity (Specific test items are: 1. the experiment of input voltage dips, interruptions and changes immunity; 2, the experiment of commutation notches immunity ; 3, the experiment of harmonic input immunity ; 4, the experiment of input frequency change; 5, the experiment of input voltage unbalance; 6, the experiment of input voltage fluctuation).

According the stringent requirements of the IEC/EN61800-3 to test and according instructions shown in the 9.3 to install, Our products will have a good EMC for the general industrial environment.

### 7.3 EMC Direction

#### 7.3.1 Harmonic Influence

The power's high-order harmonics will damage the drive. So in the area with poor power quality, propose to install the AC input reactor.

### 7.3.2 EMI and Installation Notes

Two kinds of EMI: one is electromagnetic noise of the environment to interfere the drive; the other is interference generated by drive to interfere the environment.

- ⚠️Note: A. The drive and other electrical equipments must be properly earthed.
- B. Vertically wiring of the power input and control wire is best.
- C. Output wire is proposed to use shielded cable, or use steel pipe to shield the wire, the shield must properly grounded, the interfered equipment should be shielded by multi-stranded, and the shield must properly grounded;
- D. When the length of the motor's cable is over 100m, the output filter or reactor should be installed.

### 7.3.3 Handle Interference of the Environment to Interfere the Drive

The reason of the drive's electromagnetic influence for the environment is that there are many relays, contractors and electromagnet braking in the near of the drive. When the drive does malfunction for interference, propose the following solution:

- A. Install surge absorbers in the component which can generating interference;
- B. Install filter in the drive input, refer to the 9.3.6 to operate.
- C. The wire of the drive's input and the detecting line should use shielded cable, and be properly earthed.

### 7.3.4 Handle Interference Generated by Drive to Interfere the Environment

There are two kind of the part noise: one is the radiation interference, and the other one is the conducted interference of the drive. Two kinds interference make the around equipments being induced by electromagnet or electrostatic. Then the devices have malfunctions. For several different kinds of interference, refer to the following methods to solve:

- A. Generally the signals of instruments, receivers, sensors and other for measuring are weak, if they are close to the drive or in the same cabinet with drive, the devices will be vulnerable to interference and malfunction, so propose

the following solution: try to stay away from Interference source; do not make signal lines and power lines parallel arranging, especially parallel banding together; signal lines and power lines use shielded cables, and is properly grounded; install the ferrite bead (select the suppression frequency's range in 30~1000MHz), in the output side of drive and around 2 to 3 turns, in the case of bad, can choose EMC output filter;

B. When disturbed devices and the drive use the same power, resulting in conducted interference, if the above methods can not eliminate the interference, EMC filter should be installed between the drive and power ( please refers to 9.3.6 about selection of the type);

C. Peripherals ground alone, can rule out when common ground to generate interference for the drive's ground wire having leakage

### **7.3.5 Leakage Current and Its Processing System**

When use drive, there are two kinds of leakage current: one is the leakage current to ground; the other is the leakage current between line and line.

A. Influencing factors of the earth leakage current and solutions:

There is distributing capacitance between the conductor and the earth, the distributing capacitance is greater, leakage current increases; reduce the distance between the drive and motor to effectively reduce distributing capacitance. Carrier frequency is higher, the leakage current is greater; reduce the carrier frequency to reduce leakage current. However, reducing carrier frequency will lead motor's noise to increase, the installation of the reactor is also an effective way to solve the leakage current.

Leakage current increases with the loop current increasing, so the motor power is larger, the leakage current is larger.

B. Influencing factors of the leakage current between line and line and solutions:

Exist distributing capacitance between the drive's output wiring, if the current through the line has high order harmonic, it may cause resonance and generate leakage current. the thermal relay will be malfunction.

The solution is to reduce the carrier frequency or installing the output reactor.

When use the drive, propose not to install thermal relay before the motor, and



use the drive's electronic over-current protection.

### 7.3.6 Note of Installing EMC Input Filter in the Power Input Side

A. When install EMC input filter in the power side, propose using the EMC filter produced by Shanghai Ragtop Electronic Technology Co., Ltd;

B.  attention:

Please use the filter in strict accordance with rated value; because filter belongs the I type electric, the metal ground of filter shell and the installing cabinets should be properly connected, and have good conducting continuity, Otherwise, lead to electric shock and seriously affect EMC effect;

C. Through the EMC test to find, the filter must be connected with the drive's PE to the common ground, otherwise EMC effect will seriously affected.

D. The filter should be installed as close as possible to the drive's power input side

## Chapter 8 Faults and Solutions

### 8.1 Faults and Solutions

The CM540 provides a total of 24 pieces of fault information and protective functions. After a fault occurs, the AC drive implements the protection function, and displays the fault code on the operation panel (if the operation panel is available).

Before contacting company for technical support, you can first determine the fault type, analyze the causes, and perform troubleshooting according to the following tables. If the fault cannot be rectified, contact the agent or company . E022 is the AC drive hardware over-current or overvoltage signal. In most situations, hardware overvoltage fault causes E022.

<b>Fault Name</b>	Inverter unit protection
<b>Display</b>	E001
<b>Possible Causes</b>	<ol style="list-style-type: none"> <li>1、 The output circuit is grounded or short circuited.</li> <li>2、 The connecting cable of the motor is too long.</li> <li>3、 The module overheats.</li> <li>4、 The internal connections become loose.</li> <li>5、 The main control board is faulty.</li> <li>6、 The drive board is faulty.</li> <li>7、 The inverter module is faulty.</li> </ol>
<b>Solutions</b>	<ol style="list-style-type: none"> <li>1、 Eliminate external faults.</li> <li>2、 Install a reactor or an output filter.</li> <li>3、 Check the air filter and the cooling fan.</li> <li>4、 Connect all cables properly.</li> <li>5、 Contact the agent or company</li> <li>6、 Contact the agent or company</li> <li>7、 Contact the agent or company</li> </ol>

<b>Fault Name</b>	Over-current during deceleration
<b>Display</b>	E003
<b>Possible Causes</b>	<ol style="list-style-type: none"> <li>1、 The output circuit is grounded or short circuited.</li> <li>2、 Motor auto-tuning is not performed.</li> <li>3、 The deceleration time is too short.</li> <li>4、 The voltage is too low.</li> <li>5、 A sudden load is added during deceleration.</li> <li>6、 The braking unit and braking resistor are not installed.</li> </ol>
<b>Fault Name</b>	Over-current during acceleration
<b>Display</b>	E002
<b>Possible Causes</b>	<ol style="list-style-type: none"> <li>1、 The output circuit is grounded or short circuited.</li> <li>2、 Motor auto-tuning is not performed.</li> <li>3、 The acceleration time is too short.</li> <li>4、 Manual torque boost or V/F curve is not appropriate.</li> <li>5、 The voltage is too low.</li> <li>6、 The startup operation is performed on the rotating motor.</li> <li>7、 A sudden load is added during acceleration.</li> <li>8、 The AC drive model is of too small power class.</li> </ol>
<b>Solutions</b>	<ol style="list-style-type: none"> <li>1、 Eliminate external faults.</li> <li>2、 Perform the motor auto-tuning.</li> <li>3、 Increase the acceleration time.</li> <li>4、 Adjust the manual torque boost or V/F curve.</li> <li>5、 Adjust the voltage to normal range.</li> <li>6、 Select rotational speed tracking restart or start the motor after it stops.</li> <li>7、 Remove the added load.</li> <li>8、 Select an AC drive of higher power class.</li> </ol>

Solutions	<ol style="list-style-type: none"> <li>1、 Eliminate external faults.</li> <li>2、 Perform the motor auto-tuning.</li> <li>3、 Increase the deceleration time.</li> <li>4、 Adjust the voltage to normal range.</li> <li>5、 Remove the added load.</li> <li>6、 Install the braking unit and braking resistor.</li> </ol>
-----------	--

Fault Name	Over-current at constant speed
Display	E004
Possible Causes	<ol style="list-style-type: none"> <li>1、 The output circuit is grounded or short circuited.</li> <li>2、 Motor auto-tuning is not performed.</li> <li>3、 The voltage is too low.</li> <li>4、 A sudden load is added during operation.</li> <li>5、 The AC drive model is of too small power class.</li> </ol>

Solutions	<ol style="list-style-type: none"> <li>1、 Eliminate external faults.</li> <li>2、 Perform the motor auto-tuning.</li> <li>3、 Adjust the voltage to normal range.</li> <li>4、 Remove the added load.</li> <li>5、 Select an AC drive of higher power class</li> </ol>
-----------	--

Fault Name	Overvoltage during acceleration
Display	E005
Possible Causes	<ol style="list-style-type: none"> <li>1、 The input voltage is too high.</li> <li>2、 An external force drives the motor during acceleration.</li> <li>3、 The acceleration time is too short.</li> <li>4、 The braking unit and braking resistor are not installed.</li> </ol>
Solutions	<ol style="list-style-type: none"> <li>1、 Adjust the voltage to normal range.</li> <li>2、 Cancel the external force or install a braking resistor.</li> <li>3、 Increase the acceleration time.</li> <li>4、 Install the braking unit and braking resistor.</li> </ol>

Fault Name	Overvoltage during deceleration
Display	E006
Possible Causes	<ol style="list-style-type: none"> <li>1、 The input voltage is too high.</li> <li>2、 An external force drives the motor during deceleration.</li> <li>3、 The deceleration time is too short.</li> <li>4、 The braking unit and braking resistor are not installed.</li> </ol>
Solutions	<ol style="list-style-type: none"> <li>1、 Adjust the voltage to normal range.</li> <li>2、 Cancel the external force or install the braking resistor.</li> <li>3、 Increase the deceleration time.</li> <li>4、 Install the braking unit and braking resistor.</li> </ol>

Fault Name	Overvoltage at constant speed
Display	E007
Possible Causes	1、 The input voltage is too high. 2、 An external force drives the motor during deceleration.
Solutions	1、 Adjust the voltage to normal range. 2、 Cancel the external force or install the braking resistor.

Fault Name	Control power supply fault
Display	E008
Possible Causes	The input voltage is not within the allowable range.
Solutions	Adjust the input voltage to the allowable range.

Fault Name	Under-voltage
Display	E009
Possible Causes	1、 Instantaneous power failure occurs on the input power supply. 2、 The AC drive's input voltage is not within the allowable range. 3、 The bus voltage is abnormal. 4、 The rectifier bridge and buffer resistor are faulty. 5、 The drive board is faulty. 6、 The main control board is faulty.
Solutions	1、 Reset the fault. 2、 Adjust the voltage to normal range. 3、 Contact the agent or company. 4、 Contact the agent or company 5、 Contact the agent or company6、 Contact the agent or company

Fault Name	AC drive overload
------------	-------------------

Display	E010
Possible Causes	<ol style="list-style-type: none"> <li>1、 The load is too heavy or locked rotor occurs on the motor.</li> <li>2、 The AC drive model is of too small power class.</li> </ol>
Solutions	<ol style="list-style-type: none"> <li>1、 Reduce the load and check the motor and mechanical condition.</li> <li>2、 Select an AC drive of higher power class.</li> </ol>

Fault Name	Motor overload
Display	E011
Possible Causes	<ol style="list-style-type: none"> <li>1、 F9-01 is set improperly.</li> <li>2、 The load is too heavy or locked rotor occurs on the motor.</li> <li>3、 The AC drive model is of too small power class.</li> </ol>
Solutions	<ol style="list-style-type: none"> <li>1、 Set correctly.</li> <li>2、 Reduce the load and check the motor and the mechanical condition.</li> <li>3、 Select an AC drive of higher power class.</li> </ol>

Fault Name	Power input phase loss
Display	E012
Possible Causes	<ol style="list-style-type: none"> <li>1、 The three-phase power input is abnormal.</li> <li>2、 The drive board is faulty.</li> <li>3、 The lightning board is faulty.</li> <li>4、 The main control board is faulty.</li> </ol>
Solutions	<ol style="list-style-type: none"> <li>1、 Eliminate external faults.</li> <li>2、 Contact the agent or company.</li> <li>3、 Contact the agent or company</li> <li>4、 Contact the agent or company</li> </ol>

Fault Name	Power output phase loss
Display	E013

Possible Causes	<ol style="list-style-type: none"> <li>1、 The cable connecting the AC drive and the motor is faulty.</li> <li>2、 The AC drive's three-phase outputs are unbalanced when the motor is running.</li> <li>3、 The drive board is faulty.</li> <li>4、 The module is faulty.</li> </ol>
Solutions	<ol style="list-style-type: none"> <li>1、 Eliminate external faults.</li> <li>2、 Check whether the motor three-phase winding is normal.</li> <li>3、 Contact the agent or company.</li> <li>4、 Contact the agent or company</li> </ol>

Fault Name	Module overheat
Display	E014
Possible Causes	<ol style="list-style-type: none"> <li>1、 The ambient temperature is too high.</li> <li>2、 The air filter is blocked.</li> <li>3、 The fan is damaged.</li> <li>4、 The thermally sensitive resistor of the module is damaged.</li> <li>5、 The inverter module is damaged.</li> </ol>
Solutions	<ol style="list-style-type: none"> <li>1、 Lower the ambient temperature.</li> <li>2、 Clean the air filter.</li> <li>3、 Replace the damaged fan.</li> <li>4、 Replace the damaged thermally sensitive resistor.</li> <li>5、 Replace the inverter module.</li> </ol>

Fault Name	External equipment fault
Display	E015
Possible Causes	<ol style="list-style-type: none"> <li>1、 External fault signal is input via S.</li> <li>2、 External fault signal is input via virtual I/O.</li> </ol>
Solutions	<ol style="list-style-type: none"> <li>1、 Reset the operation.</li> <li>2、 Reset the operation.</li> </ol>

Fault Name	Communication fault
Display	E016



Possible Causes	<ol style="list-style-type: none"> <li>1、 The host computer is in abnormal state.</li> <li>2、 The communication cable is faulty.</li> <li>3、 P5-28 is set improperly.</li> <li>4、 The communication parameters in group FD are set improperly.</li> </ol>
Solutions	<ol style="list-style-type: none"> <li>1、 Check the cabling of host computer.</li> <li>2、 Check the communication cabling.</li> <li>3、 Set P5-28 correctly.</li> <li>4、 Set the communication parameters properly.</li> </ol>

Fault Name	Contactor fault
Display	E017
Possible Causes	<ol style="list-style-type: none"> <li>1、 The drive board and power supply are faulty.</li> <li>2、 The contactor is faulty.</li> </ol>
Solutions	<ol style="list-style-type: none"> <li>1、 Replace the faulty drive board or power supply board.</li> <li>2、 Replace the faulty contactor.</li> </ol>

Fault Name	Current detection fault
Display	E018
Possible Causes	<ol style="list-style-type: none"> <li>1、 The HALL device is faulty.</li> <li>2、 The drive board is faulty.</li> </ol>
Solutions	<ol style="list-style-type: none"> <li>1、 Replace the faulty HALL device.</li> <li>2、 Replace the faulty drive board.</li> </ol>

Fault Name	Motor auto-tuning fault
Display	E019

Possible Causes	<ol style="list-style-type: none"> <li>1、 The motor parameters are not set according to the nameplate.</li> <li>2、 The motor auto-tuning times out.</li> </ol>
Solutions	<ol style="list-style-type: none"> <li>1、 Set the motor parameters according to the nameplate properly.</li> <li>2、 Check the cable connecting the AC drive and the motor.</li> </ol>

Fault Name	Encoder fault
Display	E020
Possible Causes	<ol style="list-style-type: none"> <li>1、 The encoder type is incorrect.</li> <li>2、 The cable connection of the encoder is incorrect.</li> <li>3、 The encoder is damaged.</li> <li>4、 The PG card is faulty.</li> </ol>
Solutions	<ol style="list-style-type: none"> <li>1、 Set the encoder type correctly based on the actual situation.</li> <li>2、 Eliminate external faults.</li> <li>3、 Replace the damaged encoder.</li> <li>4、 Replace the faulty PG card.</li> </ol>

Fault Name	EEPROM read write fault
Display	E021
Possible Causes	The EEPROM chip is damaged.
Solutions	Replace the main control board.
Fault Name	AC drive hardware fault
Display	E022
Possible Causes	<ol style="list-style-type: none"> <li>1、 Overvoltage exists.</li> <li>2、 Over-current exists.</li> </ol>

Solutions	<ol style="list-style-type: none"> <li>1、 Handle based on overvoltage.</li> <li>2、 Handle based on over-current.</li> </ol>
-----------	---

Fault Name	Short circuit to ground
Display	E023
Possible Causes	The motor is short circuited to the ground.
Solutions	Replace the cable or motor.

Fault Name	Accumulative running time reached
Display	E026
Possible Causes	The accumulative running time reaches the setting value.
Solutions	Clear the record through the parameter initialization function.

Fault Name	User-defined fault 1
Display	E027
Possible Causes	<ol style="list-style-type: none"> <li>1、 The user-defined fault 1 signal is input via S.</li> <li>2、 User-defined fault 1 signal is input via virtual I/O.</li> </ol>
Solutions	<ol style="list-style-type: none"> <li>1、 Reset the operation.</li> <li>2、 Reset the operation.</li> </ol>

Fault Name	User-defined fault 2
Display	E028
Possible Causes	<ol style="list-style-type: none"> <li>1、 The user-defined fault 2 signal is input via S</li> <li>2、 The user-defined fault 2 signal is input via virtual I/O.</li> </ol>

Solutions	<ol style="list-style-type: none"> <li>1、Reset the operation.</li> <li>2、Reset the operation.</li> </ol>
-----------	--

Fault Name	Accumulative power-on time reached
Display	E029
Possible Causes	The accumulative power-on time reaches the setting value.
Solutions	The accumulative power-on time reaches the setting value.

Fault Name	Load becoming 0
Display	E030
Possible Causes	The AC drive running current is lower than P9-64.
Solutions	Check that the load is disconnected or the setting of P9-64 and P9-65 is correct.

Fault Name	PID feedback lost during running
Display	E031
Possible Causes	The PID feedback is lower than the setting of PA-26.
Solutions	Check the PID feedback signal or set PA-26 to a proper value.

Fault Name	Pulse-by-pulse current limit fault
Display	E040
Possible Causes	<ol style="list-style-type: none"> <li>1、The load is too heavy or locked rotor occurs on the motor.</li> <li>2、The AC drive model is of too small power class.</li> </ol>

Solutions	<ol style="list-style-type: none"> <li>1、 Reduce the load and check the motor and mechanical condition.</li> <li>2、 Select an AC drive of higher power class.</li> </ol>
-----------	--

Fault Name	Motor switchover fault during running
Display	E041
Possible Causes	Change the selection of the motor via terminal during running of the AC drive.
Solutions	Perform motor switchover after the AC drive stops.

Fault Name	Too large speed deviation
Display	E042
Possible Causes	<ol style="list-style-type: none"> <li>1、 The encoder parameters are set incorrectly.</li> <li>2、 The motor auto-tuning is not performed.</li> <li>3、 P9-69 and P9-70 are set incorrectly.</li> </ol>
Solutions	<ol style="list-style-type: none"> <li>1、 Set the encoder parameters properly.</li> <li>2、 Perform the motor auto-tuning.</li> <li>3、 Set P9-69 and P9-70 correctly based on the actual situation.</li> </ol>

Fault Name	Motor over-speed
Display	E043
Possible Causes	<ol style="list-style-type: none"> <li>1、 The encoder parameters are set incorrectly.</li> <li>2、 The motor auto-tuning is not performed.</li> <li>3: P9-69 and P9-70 are set incorrectly.</li> </ol>
Solutions	<ol style="list-style-type: none"> <li>1、 Set the encoder parameters properly.</li> <li>2、 Perform the motor auto-tuning.</li> <li>3、 Set P9-69 and P9-70 correctly based on the actual situation.</li> </ol>

<b>Fault Name</b>	Motor overheat
<b>Display</b>	E045
<b>Possible Causes</b>	<ol style="list-style-type: none"><li>1、 The cabling of the temperature sensor becomes loose.</li><li>2、 The motor temperature is too high.</li></ol>
<b>Solutions</b>	<ol style="list-style-type: none"><li>1、 Check the temperature sensor cabling and eliminate the cabling fault.</li><li>2、 Lower the carrier frequency or adopt other heat radiation measures.</li></ol>



Fault Name	Initial position fault
Display	E051
Possible Causes	The motor parameters are not set based on the actual situation.
Solutions	Check that the motor parameters are set correctly and whether the setting of rated current is too small.

## 8.2 Common Faults and Solutions

You may come across the following faults during the use of the AC drive. Refer to the following table for simple fault analysis.

Table 8-2 Troubleshooting to common faults of the AC drive

SN	Fault	Possible Causes	Solutions
1	There is no display at power-on.	1: There is no power supply to the AC drive or the power input to the AC drive is too low. 2: The power supply of the switch on the drive board of the AC drive is faulty. 3: The rectifier bridge is damaged. 4: The control board or the operation panel is faulty. 5: The cable connecting the control board and the drive board and the operation panel breaks.	1: Check the power supply. 2: Check the bus voltage. 3: Re-connect the 8-core and 28-core cables. 4: Contact the agent or company for technical support.
2	"HC" is displayed at power-on.	1: The cable between the drive board and the control board is in poor contact. 2: Related components on the control board are damaged. 3: The motor or the motor cable is short circuited to the ground. 4: The HALL device is faulty. 5: The power input to the AC Drive is too low.	1: Re-connect the 8-core and 28-core cables. 2: Contact the agent or company for technical support.



3	“E023” is displayed at power-on.	<ol style="list-style-type: none"> <li>1: The motor or the motor Output cable is short-circuited to the ground.</li> <li>2: The AC drive is damaged.</li> </ol>	<ol style="list-style-type: none"> <li>1: Measure the insulation of the motor and the output cable with a megger.</li> <li>2: Contact the agent or company for technical support.</li> </ol>
SN	Fault	Possible Causes	Solutions
4	The AC drive display is normal upon power-on. But “HC” is displayed after running and ops	<ol style="list-style-type: none"> <li>1: The cooling fan is damaged or locked-rotor occurs.</li> <li>2: The external control terminal cable is short circuited.</li> </ol>	<ol style="list-style-type: none"> <li>1: Replace the damaged fan.</li> <li>2: Eliminate external fault.</li> </ol>
5	E014 (module overheat) fault is reported frequently.	<ol style="list-style-type: none"> <li>1: The setting of carrier frequency is too high.</li> <li>2: The cooling fan is damaged, or the air filter is blocked.</li> <li>3: Components inside the AC drive are damaged (thermal coupler or others).</li> </ol>	<ol style="list-style-type: none"> <li>1: Reduce the carrier Frequency (P5-15).</li> <li>2: Replace the fan and clean The air filter.</li> <li>3: Contact the agent or company for technical support.</li> </ol>
6	The motor does not rotate after the AC drive runs.	<ol style="list-style-type: none"> <li>1: Check the motor and the motor cables.</li> <li>2: The AC drive parameters are set improperly (motor parameters).</li> <li>3: The cable between the drive board and the control board is in poor contact.</li> <li>4: The drive board is faulty.</li> </ol>	<ol style="list-style-type: none"> <li>1: Ensure the cable between the AC drive and the motor is normal.</li> <li>2: Replace the motor or clear mechanical faults.</li> <li>3: Check and re-set motor parameters.</li> </ol>
7	The DI terminals are disabled.	<ol style="list-style-type: none"> <li>1: The parameters are set incorrectly.</li> <li>2: The external signal is incorrect.</li> <li>3: The jumper bar across OP and +24V becomes loose.</li> <li>4: The control board is faulty.</li> </ol>	<ol style="list-style-type: none"> <li>1: Check and reset the parameters in group H4.</li> <li>2: Re-connect the external signal cables.</li> <li>3: Re-confirm the jumper bar across OP and +24 V.</li> <li>4: Contact the agent or company for technical support.</li> </ol>

8	The motor speed is always low in CLVC mode.	<ol style="list-style-type: none"> <li>1: The encoder is faulty.</li> <li>2: The encoder cable is connected incorrectly or in poor contact.</li> <li>3: The PG card is faulty.</li> <li>4: The drive board is faulty.</li> </ol>	<ol style="list-style-type: none"> <li>1: Replace the encoder and ensure the cabling is proper.</li> <li>2: Replace the PG card.</li> <li>3: Contact the agent or company for technical support.</li> </ol>
9	The AC drive reports over-current and overvoltage frequently.	<ol style="list-style-type: none"> <li>1: The motor parameters are set improperly.</li> <li>2: The acceleration/deceleration time is improper.</li> <li>3: The load fluctuates.</li> </ol>	<ol style="list-style-type: none"> <li>1: Re-set motor parameters or re-perform the motor auto-tuning.</li> <li>2: Set proper acceleration/ deceleration time.</li> <li>3: Contact the agent or company for technical support.</li> </ol>
10	E017 is reported upon power-on or running.	The soft startup contactor is Not picked up.	<ol style="list-style-type: none"> <li>1: Check whether the contactor cable is loose.</li> <li>2: Check whether the contactor is faulty.</li> <li>3: Check whether 24V power supply of the contactor is faulty.</li> <li>4: Contact the agent or company for technical support.</li> </ol>
11	<u>AAAAA</u> Is displayed upon power-on.	Related component on the control board is damaged.	Replace the control board.

## **Appendix E: CM540 Modbus Communication Protocol**

CM540 series inverter provide RS485 communication interface, and support Modbus-RTU communication protocol. The user could centralized control through PC or plc. This communication protocol could set inverter operation command, change and read function code parameter, and read inverter working state and fault information.

### **I .Protocol Content**

The serial communication protocol definite the deliver content of series communication and use format. Including: host machine poll(broadcast) format; the coding method of host machine, the content is as follows: request of operative function code, deliver data and error verify etc. if the slave report error when it receive information, or couldn't finish the request of operative function , it will organize an error report to feedback to host machine.

#### 1.Method

The inverter connects "MCU" PC/PLC control net with RS485, as communication slave machine.

#### 2.Bus structure

##### a) Method of interface

RS485 hardware interface

##### b ) Topological structure

Single host and sever slave system. The setting range of slave address is 1~247, 0 is broadcast communication address. The net slave address is only.

##### c ) Communication deliver method.

Asynchronization serial, half duplex transmission. The host and slave just send the data by only one, the other one accept the data at the same time. The data in serial asynchronization communication is sent one by one in message.

CM540 series inverter communication protocol is an asynchronization serial host-slave Modbus one, and the only one equipment could build protocol in the net. The slaves just response or make some action the host query command

through providing data.

Host means PC, industry control equipment or PLC etc; the slave means CM540 series inverter. Host could communicate with one slave, and also communicate with all the slave. For visiting the host “query/command”, the slave need response. But for the broadcast from the host, the slave not need to response.

## II. Protocol Form

1. CM540 series MODBUS protocol form as follows;

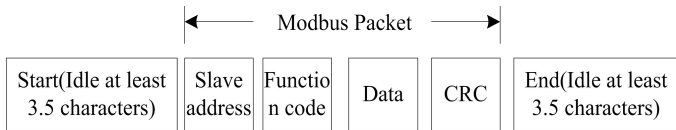

2. RTU frame format:

FH START	3.5 characters time
Slave address ADR	Communication address: 1~247, the address is 0 which is representative broadcast address
Command code CMD	03: read slave parameter; 06: write slave parameter
Digit content DATA ( N-1 )	Function code parameter address, quantity of function code parameter and value
Digit content DATA ( N-2 )	
.....	
Digit content DATA0	
CRC CHK high-order	Test value: CRC value
CRC CHK low-order	
END	3.5 characters time

### CMD and DATA

- a) Command code: 03H, read N words ( Word X maximum reading quantity is 12 )
- b) Command code: 06H read one word ( Word ), for example: read 5000 ( 1388H )

to slave address 02H, the F00AH address of inverter.

c) CRC methods:

CRC( Cyclical Redundancy Check ) use RTU frame format, the message include error detection region based on CRC. CRC region detects the whole message content. CRC region is two bytes, including CRC a 16-bit binary values. It is calculated by the deliver equipment and added to message. The receiving equipment recalculate the receiving CRC, and compare with the value in CRC regain. If the two CRC is different, which means the deliver is wrong.

CRC is stored in 0xFFFF first, and then transfer and settle continuous 8 bytes and value in current register. just 8bit in each character is valid for CRC, start bit and stop bit and parity check bit is all invalid.

In the CRC producing process, each 8 bit character need to be different with the content of register. The result move to LSB, and the MSD is filled by 0. If the tested LSB is 1, register is different with the preset value. The whole process need repeat 8 times.

CRC is add to message, and low byte first and the high byte, CRC simple function is as follows;

```
unsigned int crc_chk_value ( unsigned char *data_value,unsigned char length )
{
    unsigned int crc_value=0xFFFF;
    int i;
    while ( length-- )
    {
        crc_value^=*data_value++;
        for ( i=0;i<8;i++ )
        {
            if ( crc_value&0x0001 )
            {
                crc_value= ( crc_value>>1 )
            }
        }
    }
}
```

```

^0xa001;
    }
    else
    {
        crc_value=crc_value>>1;
    }
}
}
return ( crc_value ) ;
}

```

d) Definition of communication protocol address Use function code group no. and mark no. to show rules:

High byte:F0~FF ( group ), A0~AF ( C group ), 70~7F ( d group )

Low byte:00~FF

For example: function code is H1.12 , address is 0xF10C;

Note:

FF group: could not read and change parameters;

d group: could just read, but not change parameter.

Some parameter couldn't be changed when the inverter is running; some other parameter never be changed in any state; if we want to change the function code parameter, please note the range, unit and description of the parameter.

Function code group	Communication visit address	Communication modify the Function code address of RAM
H0~HE Group	0xF000~0xFEFF	0x0000~0xEFF
C0~CC Group	0xA000~0xACFF	0x4000~0x4CFF
d0 Group	0x7000~0x70FF	

In addition, the life of the EE PROM will be shortened if EE PROM is frequently

stored. So the users should reduce the times of storing EE PROM. And some parameter under communication mode is no need to store, and just need to change the value in RAM.

If the H group parameter, and need to realize above function, just change the function code high bit H to 0.

If the C group parameter, and need to realize above function, just change the function code high bit C to 4.

The corresponding function code address is as follows;

High byte: 00~0F ( H group ), 40~4F ( C group )

Low byte: 00~FF

Such as: function code H1.12 won't be stored to EEPROM , address is 0x010C;

Function code C0.06 won't be stored to EEPROM , address is 0x4006;

The address is just written RAM , not to read.

**Halt/operation parameter:**

Parameter Address	Parameter Description
0x 1000	Communication setting value ( -10000~10000 )( decima
0x 1001	Operation frequency
0x 1002	Bus voltage
0x 1003	Output voltage
0x 1004	Output current
0x 1005	Output power
0x 1006	Output torque
0x 1007	Operation speed
0x 1008	S terminal input mark

0x 1009	DO terminal output mark
0x 100A	AI1 voltage
0x 100B	AI2 voltage
0x 100C	AI3 voltage
0x 100D	count value input
0x 100E	length input
0x 100F	load speed
0x 1010	PID setting
0x 1011	PID feedback
0x 1012	PLC step
0x 1013	HDI input pulse frequency, unit 0.01kHz
0x 1014	Feedback speed, unit 0.1Hz
0x 1015	residue operation time
0x 1016	AI1 voltage before revising
0x 1017	AI2 voltage before revising
0x 1018	AI3 voltage before revising
0x 1019	linear speed
0x 101A	current power on time
0x 101B	Current running time
0x 101C	HDI input pulse frequency, unit 1Hz
0x 101D	Communication setting value
0x 101E	Practical feedback speed
0x 101F	Main frequency A display
0x 1020	Auxiliary frequency B display

Note: communication setting value is relative vale percentage, 10000 is corresponding 100.00%, -10000 is corresponding -100.00%.



For the frequency dimensional data, the percent is corresponding to the max frequency (P5-10);for the torque dimensional data, the percent is P2-10,H2-48.

Control command input to inverter(just write)

Command Word Address	Command Function
0x2000	0001:foreward running
	0002: reverse running
	0003: foreword jog
	0004: reverse jog
	0005:halt freely
	0006:slowing down halt
	0007:fault reset

Read inverter state: ( read only )

Status word address	Status word function
0x 3000	0001:foreward running
	0002:reveral running
	0003:halt

Parameter lock password verify: ( if back to 8888H , means password verify successfully )

Password address	Input password content
0x 1F00	*****
0x 2001	BIT0:SP2 output control BIT1:TA3-TB3-TC3 relay 3 output control BIT2:TA1-TB1-TC1 relay 1 output control BIT3:TA2-TB2-TC2 relay 2 output control BIT4:SP1 output control BIT5:XDO1;BIT6:XDO2 BIT7:XDO3;BIT8:XDO4 BIT9: XDO5

Analog output A01 control : ( write only )

Command address	Command content
0x 2002	0~7FFF means 0%~100%

Analog output A02 control : ( write only )

Command address	Command content
0x 2003	0~7FFF means 0%~100%

Pulse ( HDI ) output control : ( write only )

Command address	Command content
0x 2004	0~7FFF means 0%~100%

Inverter fault description:

Inverter fault address	Inverter fault information
0x8000	0000:no fault 0001:retain 0002:Over-current during acceleration 0003:Over-current during deceleration 0004:Over-current in constant speed operation 0005:Over-voltage during acceleration 0006:Over-voltage during deceleration 0007:Over-voltage in constant speed 0008:buffer resistance over-load fault 0009:underload fault 000A:inverter overload 000B:motor overload 000C:input phase loss 000D:outputphase loss

000E:module over-heat
000F:external fault
0010:communication abnormal
0011:contactor abnormal
0012:current detecting fault
0013:motor tune fault
0014:encoder/PG card fault
0015:parameter read and write abnormal
0016:inverter hardware fault
0017:motor short trouble to ground
0018:retain
0019:retain
001A:reach operation time
001B>User defined fault 1
001C>User defined fault 2
001D:reach power on time
001E:lose load
001F:PID feedback lose in running
0028:rapid current-limiting overtime fault
0029:switch motor fault in running
002A:speed variation larger
002B:motor over-speed
002D:motor over-heat
005A:encoder wiring setting error
005B:unconnect encoder
005C:initial position error
005E:speed feedback error

**HD Group Communication Parameter Description**

Pd-00	Baud rate	Default	6005
	Setting range	Unit: MODUBS baud rate 0:300BPS 1:600BPS 2:1200BPS 3:2400BPS 4:4800BPS 5:9600BPS 6:19200BPS 7:38400BPS 8:57600BPS 9:115200BPS	

This parameter is used to set the data deliver speed between upper machine and inverter. note: the baud rate of upper machine is same with inverter, otherwise the communication couldn't continue. The baud rate is larger, the speed of communication is higher.

Pd-01	Data format	Default	0
	Setting range	0:No verify: Data format<8,N,2> 1:even verify: Data format<8,E,1> 2:odd verify: Data format<8,O,1> 3:No verify: Data format<8-N-1>	

The upper machine is same with the inverter's setting format, otherwise the communication couldn't continue.

Pd-02	Machine address	Default	1
	Setting range	1~247 , 0 is broadcast address	

The machine address set to 0, and broadcast address, realize upper machine

Pd-03	Response delay	Default	2ms
	Setting range	0~20ms	

broadcast function.

Response delay: it means the time between the finish time of inverter data receiving and upper machine send data time. If the response time is less than system handle time, the response delay time is according to system handle time, if the response delay is longer than system handle time, wait the system handle the data, till get the response delay, and send the data to upper machine.

Pd-04	Communication overtime	Default	0.0 s
	Setting range	0.0 s ( invalid ) ;0.1~60.0s	

When the function code is set to 0.0s, the communication overtime parameter is invalid.

When the function code is valid value, the time between two communication time is over communication overtime, the system will report E016. Generally it is set to invalid.

Set Sub parameter to watch the communication state in the continue communication system.

### **Guarantee Agreement**

Warranty of the company products executes in accordance with "the quality assurance" in instructions.

1. Warranty period is 12 months from the date of purchasing the product
2. Even within 12 months, maintenance will also be charged in the following situations:
  - 2.1. Incorrect operation (according to the manual) or the problems are caused by unauthorized repair or transformation.
  - 2.2. The problems are caused by exceeding the requirements of standards specifications to use the drive.
  - 2.3 After purchase, loss is caused by falling damage or improper transportation.
  - 2.4 The devices' aging or failure is caused by bad environment (corrosive gas or liquid).
  - 2.5 Earthquake, fire wind disaster, lightning, abnormal voltage or other

accompanied natural disasters cause the damage.

2.6 Damage is caused during transport (note: the mode of transportation is determined by customers, the company helps to handle the transferring procedures of goods).

2.7 Unauthorized tearing up the product identification (e.g.: Nameplate, etc.); the serial number does not match the warranty card.

2.8 Failing to pay the money according purchase agreement.

2.9 Can not objective actually describe the installation, wiring, operation, maintenance or other using situation to the company's service units.